

TM 10-8470-209-10

**TECHNICAL MANUAL
OPERATOR'S MANUAL
FOR**

SOLDIER PLATE CARRIER SYSTEM (SPCS)

**X-SMALL (NSN 8470-01-592-9461), SMALL (NSN 8470-01-592-9468),
MEDIUM (NSN 8470-01-592-9479), LARGE (NSN 8470-01-592-9480),
X-LARGE (NSN 8470-01-592-9484), XX-LARGE (NSN 8470-01-592-9485)**



DISTRIBUTION STATEMENT A – Approved for public release; distribution is unlimited.

HEADQUARTERS, DEPARTMENT OF THE ARMY

1 DECEMBER 2013

WARNING SUMMARY

This warning summary contains general safety warnings and hazardous materials warnings that must be understood and applied during operation and maintenance of this equipment. Failure to observe these precautions could result in serious injury or death to personnel. Also included are explanations of safety and hazardous material icons used within the technical manual.

FIRST AID DATA

For first aid information, refer to FM 4-25.11.

WARNING DESCRIPTIONS

WARNING

Failure to follow all cleaning instructions could deteriorate, damage, or destroy the Plate Carrier and result in degraded ballistic protection. Degraded ballistic protection may cause injury or death to the user.

WARNING

Do not machine wash or dry the fabric carriers, the soft ballistic inserts, or the hard armor plates. Failure to follow these instructions may degrade your ballistic protection. Degraded ballistic protection may cause injury or death to the user.

Remove all soft armor and hard armor protective inserts prior to cleaning. Failure to follow these instructions may degrade ballistic protection. Degraded ballistic protection may cause injury or death to the user.

WARNING

Personnel must ensure they have the correct protective inserts. The ESAPI and ESBI have green covers and the XSAPI and XSBI have tan covers. Both provide a higher level of protection than the Small Arms Protective Insert (SAPI) which has a black cover. ESAPI or XSAPI and ESBI or XSBI should be worn by all personnel in-theater. If a Soldier has the older black SAPI plates, they should be turned in and replaced with green ESAPI/ESBI plates or tan XSAPI/XSBI plates. Failure to ensure the correct plate while conducting combat operations may result in injury or death to the user.

WARNING DESCRIPTIONS – CONTINUED

WARNING

Fabric repair in this TM does not apply to the fabric on the soft ballistic inserts. Any damage to the soft ballistic inserts is cause for turn-in. Failure to follow these instructions could result in degraded ballistic protection. Degraded ballistic protection may cause injury or death to the user.

WARNING

The emergency release system should be used during emergencies or instructional purposes only. Using the cable release method to routinely doff the vest could result in damage to the hard armor plates. Damage to the hard armor plates could result in degraded ballistic protection, which may cause injury or death to the user.

WARNING

Ensure the sizes of the front and back carrier match by comparing data label information. Ensure the sizes of the side plate carriers match the sizes of the front and back carriers by comparing data plate information. Failure to do so could affect performance, causing injury or death to the user.

WARNING

Ensure the hard armor plates are positioned on the body so that they cover the essential areas of the body. Incorrectly positioned plates could affect performance, causing injury or death to the user.

END OF WORK PACKAGE

LIST OF EFFECTIVE PAGES/WORK PACKAGES

NOTE: Zero in the "Change No." column indicates an original page or work package.

Original: 1 December 2013

TOTAL NUMBER OF PAGES FOR FRONT AND REAR MATTER IS 20 AND TOTAL NUMBER OF WORK PACKAGES IS 25, CONSISTING OF THE FOLLOWING:

Page / WP No.	Change No.
Front Cover	0
Warning (2 pgs)	0
i-xii (12 pgs)	0
Ch 1 title page (2 pgs)	0
WP 0001 (4 pgs)	0
WP 0002 (20 pgs)	0
WP 0003 (8 pgs)	0
Ch 2 title page (2 pgs)	0
WP 0004 (2 pgs)	0
WP 0005 (30 pgs)	0
WP 0006 (30 pgs)	0
WP 0007 (8 pgs)	0
WP 0008 (2 pgs)	0
Ch 3 title page (2 pgs)	0
WP 0009 (2 pgs)	0
WP 0010 (8 pgs)	0
Ch 4 title page (2 pgs)	0
WP 0011 (4 pgs)	0
WP 0012 (8 pgs)	0
WP 0013 (8 pgs)	0
WP 0014 (6 pgs)	0
WP 0015 (6 pgs)	0
WP 0016 (2 pgs)	0
WP 0017 (2 pgs)	0
WP 0018 (2 pgs)	0
WP 0019 (2 pgs)	0
WP 0020 (2 pgs)	0
WP 0021 (2 pgs)	0
Ch 5 title page (2 pgs)	0
WP 0022 (2 pgs)	0
WP 0023 (4 pgs)	0
WP 0024 (4 pgs)	0
WP 0025 (2 pgs)	0
Back cover	0

HEADQUARTERS
DEPARTMENT OF THE ARMY
WASHINGTON, D.C., 1 DECEMBER 2013

**TECHNICAL MANUAL
OPERATOR'S MANUAL
FOR
SOLDIER PLATE CARRIER SYSTEM (SPCS)**

**X-SMALL (NSN 8470-01-592-9461), SMALL (NSN 8470-01-592-9468),
MEDIUM (NSN 8470-01-592-9479), LARGE (NSN 8470-01-592-9480),
X-LARGE (NSN 8470-01-592-9484), XX-LARGE (NSN 8470-01-592-9485)**

REPORTING ERRORS AND RECOMMENDING IMPROVEMENTS

You can help improve this publication. If you find any errors, or if you would like to recommend any improvements to the procedures in this publication, please let us know. The preferred method is to submit your DA Form 2028 (Recommended Changes to Publications and Blank Forms) through the Internet on the TACOM Unique Logistics Support Applications (TULSA) Web site. The Internet address is <https://tulsa.tacom.army.mil>. Access to all applications requires CAC authentication, and you must complete the Access Request form the first time you use it. The DA Form 2028 is located under the TULSA Applications on the left-hand navigation bar. Fill out the form and click on SUBMIT. Using this form on the TULSA Web site will enable us to respond more quickly to your comments and to better manage the DA Form 2028 program. You may also mail, e-mail, or fax your comments or DA Form 2028 directly to the U.S. Army TACOM Life Cycle Management Command. The postal mail address is U.S. Army TACOM Life Cycle Management Command, ATTN: AMSTA-LCL-MPP/ TECH PUBS, MS 727, 6501 E. 11 Mile Road, Warren, MI 48397-5000. The e-mail address is tacomlcmc.daform2028@us.army.mil. The fax number is DSN 786-1856 or Commercial (586) 282-1856. A reply will be furnished to you.

DISTRIBUTION STATEMENT A: Approved for public release; distribution is unlimited.

TABLE OF CONTENTS

WP Sequence No.
Page No.

How to Use This Manual.....xi

Chapter 1 – General Information, Equipment Description and Data, and Theory of Operation

General Information	WP 0001
Table 1. Nomenclature Cross Reference List	WP 0001 -2
Table 2. List of Abbreviations/Acronyms	WP 0001 -3
Equipment Description and Data	WP 0002
Figure 1. Front Carrier Exterior	WP 0002 -2
Figure 2. Opening the Front Carrier	WP 0002 -3
Figure 3. Quick Release Cable Routing (Interior of Front Carrier with Components Shown for Clarity) – Side Plate Carrier Configuration).....	WP 0002 -4
Figure 4. Front Carrier Open for Soft Ballistic Insert.....	WP 0002 -5
Figure 5. Quick Release Buckles	WP 0002 -5
Figure 6. Back Carrier Exterior	WP 0002 -6
Figure 7. Opening the Back Carrier	WP 0002 -7
Figure 8. Back Carrier Interior Open for Soft Ballistic Insert.....	WP 0002 -8
Figure 9. Shoulder Straps	WP 0002 -9
Figure 10. Right Side Plate Carrier Exterior.....	WP 0002 -9
Figure 11. Right Side Plate Carrier with Pocket for ESBI/XSBI Open	WP 0002 -10
Figure 12. Angled T-Strap with Separation Strap Attached.....	WP 0002 -10
Figure 13. Cable Release Assembly.....	WP 0002 -11
Figure 14. Attachment Strap	WP 0002 -11
Figure 15. Back Carrier with Cummerbund and Side Pockets	WP 0002 -12
Figure 16. Vest Soft Ballistic Insert	WP 0002 -13
Figure 17. Side Soft Ballistic Insert	WP 0002 -13
Figure 18. Cummerbund Soft Ballistic and Plastic Stiffener	WP 0002 -13
Figure 19. hHard Armor Plates (ESAPI Shown)	WP 0002 -14
Figure 20. Side Hard Armor Plates (ESBI Shown)	WP 0002 -15

	<u>WP Sequence No.</u> <u>Page No.</u>
Table 1. Differences between Models.....	WP 0002-16
Table 2. Plate Carrier System Weight Chart (in pounds).....	WP 0002-19
Theory of Operations	WP 0003
Figure 1. Plate Carrier Basic Inventory (Non-Side Plate Carrier Configuration).....	WP 0003-1
Figure 2. Basic Inventory with Side Plate Carriers (Side Plate Carrier Configuration).....	WP 0003-2
Figure 3. Basic Inventory with Cummerbund Assembly (Cummerbund Configuration).....	WP 0003-2
Figure 4. Hard Armor Plates	WP 0003-4
Figure 5. Inventory of Side Plate Carrier Configuration with Hard Armor Plates.....	WP 0003-5
Figure 6. Inventory of Cummerbund Configuration with Hard Armor Plates.....	WP 0003-6
Figure 7. Pulling the Quick Release Cable	WP 0003-7

Chapter 2 – Operator Instructions for Soldier Plate Carrier System

Operator Controls and Indicators	WP 0004
Operation Under Usual Conditions – Side Plate Carrier Configuration – Assembly and Disassembly	WP 0005
Figure 1. Soldier Plate Carrier System (Side Plate Carrier Configuration).....	WP 0005-1
Table 1. Plate Carrier Inventory (Side Plate Carrier Configuration).....	WP 0005-2
Table 2. Plate Carrier Component (Side Plate Carrier Configuration) Sizing Chart.....	WP 0005-5
Figure 2. Attaching Shoulder Strap to Back Carrier.....	WP 0005-6
Figure 3. Stowing the Shoulder Strap and Slide	WP 0005-7
Figure 4. Access to Cable Release Channels	WP 0005-7
Figure 5. Inserting Cable Ends through Holes in Cable Release Pocket.....	WP 0005-8
Figure 6. Pulling Both Cables through Holes.....	WP 0005-8
Figure 7. Inserting Shoulder Strap through Tri-Glide Slide on Front Carrier.....	WP 0005-9

Figure 8. Threading the Cable through Shoulder Strap Loop (Interior View).....	WP 0005-10
Figure 9. Inserting a Quick Release Buckle through Metal Ring (Interior View)	WP 0005-10
Figure 10. Threading Cable through Quick Release Buckle (Interior View).....	WP 0005-11
Figure 11. Stowing the End of the Cable	WP 0005-11
Figure 12. Separation Strap Assembly Attached to Angled T-Strap	WP 0005-12
Figure 13. Separation Strap Assemblies Attached to SPC Straps ..	WP 0005-12
Figure 14. Side Plate Carriers Prepared for Angled T-Strap	WP 0005-13
Figure 15. Snap End Under Webbing	WP 0005-13
Figure 16. D-Ring Passed Under Webbing.....	WP 0005-14
Figure 17. Properly Inserted Angled T-Strap	WP 0005-14
Figure 18. Side Plate Carrier with Angled T-Strap	WP 0005-15
Figure 19. Opening the Back Carrier	WP 0005-15
Figure 20. D-Ring for Attaching SPC Strap	WP 0005-16
Figure 21. Attaching Angled T-Strap to D-Ring	WP 0005-16
Figure 22. Tucking Extra Webbing into Back Carrier.....	WP 0005-17
Figure 23. Inserting Middle SPC Strap	WP 0005-17
Figure 24. Attaching Middle SPC Strap to Back Carrier	WP 0005-18
Figure 25. Attaching Lower SPC Strap to Back Carrier.....	WP 0005-18
Figure 26. Inserting Attachment Strap into Back Carrier	WP 0005-19
Figure 27. Attaching Attachment Strap to Back Carrier.....	WP 0005-19
Figure 28. Attaching Lower Attachment Strap to Back Carrier	WP 0005-20
Figure 29. Opening the Soft Ballistic Insert Pocket of Front Carrier	WP 0005-20
Figure 30. Inserting Soft Ballistic into Front Carrier	WP 0005-21
Figure 31. Opening Outer Cover of Front Carrier	WP 0005-22
Figure 32. Opening ESAPI/XSAPI Pocket.....	WP 0005-22
Figure 33. Inserting ESAPI/XSAPI.....	WP 0005-23

Figure 34. Opening Interior Compartment of Side Plate Carrier.....	WP 0005-24
Figure 35. Inserting Soft Ballistic in Side Plate Carrier	WP 0005-24
Figure 36. Inserting ESBI/XSBI under Compartment for Soft Ballistic.....	WP 0005-25
Figure 37. Removing ESAPI/XSAPI Plate from Pocket.....	WP 0005-26
Figure 38. Removing Soft Ballistic Insert from Front Carrier	WP 0005-27
Figure 39. Side Plate Carriers Buckled to Front Carrier	WP 0005-28
Figure 40. Detaching Side Plate Carrier Snaps from Back Carrier	WP 0005-28
Figure 41. Detaching Shoulder Straps from Back Carrier	WP 0005-29
 Operation Under Usual Conditions – Cummerbund Configuration – Assembly and Disassembly.....	
	WP 0006
Figure 1. Soldier Plate Carrier System (Cummerbund Configuration).....	WP 0006-1
Table 1. Plate Carrier Inventory (Cummerbund Configuration)	WP 0006-2
Table 2. Plate Carrier Component (Cummerbund Configuration) Sizing Chart.....	WP 0006-5
Figure 2. Inside Pocket of Side Plate Pocket.....	WP 0006-6
Figure 3. Exterior and Interior of SPCS (Cummerbund Configuration).....	WP 0006-7
Figure 4. Attaching Shoulder Strap to Back Carrier.....	WP 0006-8
Figure 5. Stowing the Shoulder Strap and Tri-Glide Slide	WP 0006-8
Figure 6. Access to Cable Release Channels	WP 0006-9
Figure 7. Inserting Cable Ends through Holes in Cable Release Pocket.....	WP 0006-9
Figure 8. Pulling both Cables through Holes	WP 0006-10
Figure 9. Inserting Shoulder Strap through Tri-Glide Slide on Front Carrier.....	WP 0006-10
Figure 10. Threading the Cable through Shoulder Strap Loop (Interior View).....	WP 0006-11
Figure 11. Inserting a Male Quick Release Buckle through Metal Ring (Interior View).....	WP 0006-11
Figure 12. Stowing the End of the Cable	WP 0006-12

Figure 13. Separation Strap Assembly Attached to Angled T-Strap	WP 0006-13
Figure 14. Separation Strap Assemblies Attached to Cummerbund Attachment Straps.....	WP 0006-13
Figure 15. Snap End Under Webbing	WP 0006-14
Figure 16. D-Ring Passed Under Webbing.....	WP 0006-14
Figure 17. Properly Inserted Angled T-Strap	WP 0006-16
Figure 18. Side Plate Pocket and Cummerbund	WP 0006-15
Figure 19. Inserting Straps of Side Plate Pocket through Webbing	WP 0006-16
Figure 20. Pocket Straps Fully Inserted in Cummerbund	WP 0006-16
Figure 21. Data Labels Facing the Same Direction	WP 0006-17
Figure 22. Positioning Cummerbund Assembly for Attachment	WP 0006-18
Figure 23. Opening the Back Carrier	WP 0006-18
Figure 24. Pull D-Ring through to Outside of Back Carrier.....	WP 0006-19
Figure 25. Insert Snap End of Angle Strap through D-Ring.....	WP 0006-19
Figure 26. Top Strap of Cummerbund Inserted in Back Carrier	WP 0006-20
Figure 27. Insert Snap End through Inside Metal Ring.....	WP 0006-20
Figure 28. Left Cummerbund Assembly Attached to Back Carrier..	WP 0006-21
Figure 29. Back Carrier with Cummerbund Assembly Installed	WP 0006-22
Figure 30. Inserting a Soft Ballistic into Front Carrier	WP 0006-23
Figure 31. Plastic Stiffener and Soft Ballistic Inserts in Cummerbund.....	WP 0006-24
Figure 32. Soft Ballistic Insert in Side Plate Pocket.....	WP 0006-24
Figure 33. Close Inner Pocket.....	WP 0006-25
Figure 34. Opening Outer Cover of Front Carrier	WP 0006-25
Figure 35. Opening ESAPI/XSAPI Pocket.....	WP 0006-26
Figure 36. Inserting ESAPI/XSAPI.....	WP 0006-26
Figure 37. Inserting ESBI/XSBI under Soft Ballistic Compartment	WP 0006-27
Figure 38. Removing ESAPI/XSAPI from Pocket.....	WP 0006-28

	<u>WP Sequence No.</u>
	<u>Page No.</u>
Figure 39. Detaching Cummerbund from Back Carrier	WP 0006-29
Figure 40. Detaching Shoulder Straps from Back Carrier	WP 0006-30
Operation Under Usual Conditions – Don, Doff, Adjust	WP 0007
Figure 1. Over-the-Head Donning.....	WP 0007-1
Figure 2. Buckling the Quick Release Buckles	WP 0007-2
Figure 3. Detach the Four Buckles	WP 0007-3
Figure 4. Pulling the Quick Release Tab	WP 0007-4
Figure 5. Checking Fit of Plate Carrier.....	WP 0007-5
Figure 6. Shoulder Strap Adjustment Points.....	WP 0007-6
Figure 7. Side Carrier Adjustment Points.....	WP 0007-7
Operation Under Unusual Conditions.....	WP 0008

Chapter 3 – Preventive Maintenance Checks and Services for Soldier Plate Carrier System

Preventive Maintenance Checks and Services (PMCS) Introduction	WP 0009
Preventive Maintenance Checks and Services (PMCS).....	WP 0010
Table 1. Preventive Maintenance Checks and Services for the Soldier Plate Carrier System	WP 0010-2
Figure 1. Smoothing Out Plate Carrier.....	WP 0010-2
Figure 2. Front/Back Carrier Soft Ballistic Insert, Side Pocket/Side Plate Carrier Soft Ballistic Insert, Cummerbund Soft Ballistic Insert and Polyethylene Plastic Insert (from left to right)	WP 0010-3
Figure 3. Cable Release Routing (Cable Shown on Top of Vest for Clarity)	WP 0010-4
Figure 4. Shoulder Strap through Tri-Glide Slide.....	WP 0010-5
Figure 5. Cable Retainer Channel	WP 0010-6
Figure 6. Proper Arrangement of Quick Release Buckle and Release Cable.....	WP 0010-6
Figure 7. Inspect Plates	WP 0010-7

Chapter 4 – Maintenance Instructions for Soldier Plate Carrier System

Cleaning and Drying	WP 0011
---------------------------	---------

Carrier Replace.....	WP 0012
Figure 1. Removing ESAPI/XSAPI from ESAPI/XSAPI Pocket.....	WP 0012-1
Figure 2. Removing ESBI/XSBI from Side Plate Carrier	WP 0012-2
Figure 3. Removing Soft Ballistic Insert from Front Carrier	WP 0012-3
Figure 4. Opening Soft Ballistic Insert Pocket on Front Carrier	WP 0012-3
Figure 5. Inserting Soft Ballistic into Front Carrier	WP 0012-4
Figure 6. Opening Outer Cover of Front Carrier	WP 0012-5
Figure 7. Opening ESAPI/XSAPI Pocket.....	WP 0012-5
Figure 8. Inserting ESBI/XSBI.....	WP 0012-6
Figure 9. Inserting ESBI/XSBI under Soft Ballistic Insert.....	WP 0012-7
Side Plate Carrier Replace	WP 0013
Figure 1. Detaching Quick Release Buckles.....	WP 0013-1
Figure 2. Detaching Side Plate Carrier Snaps from Back Carrier....	WP 0013-1
Figure 3. Inserting Soft Ballistic	WP 0013-2
Figure 4. Opening the Back Carrier	WP 0013-3
Figure 5. Pulling Out the Angled SPC Strap Attachment D-Ring from Back Carrier	WP 0013-4
Figure 6. Attaching Angled T-Strap to D-Ring	WP 0013-4
Figure 7. Tucking Extra Webbing into Back Carrier.....	WP 0013-5
Figure 8. Inserting Middle SPC Strap	WP 0013-5
Figure 9. Attaching the Middle SPC Strap to Back Carrier	WP 0013-6
Figure 10. Attaching Lower SPC Strap to Back Carrier.....	WP 0013-6
Cummerbund Assembly Replace	WP 0014
Figure 1. Detaching Quick Release Buckles.....	WP 0014-1
Figure 2. Detaching the Cummerbund Assembly from Back Carrier	WP 0014-1
Figure 3. Positioning Assembled Cummerbund for Attachment.....	WP 0014-2
Figure 4. Pull D-Ring through to Outside of Back Carrier.....	WP 0014-3
Figure 5. Insert Snap End of Angled T-Strap through D-Ring	WP 0014-3
Figure 6. Top Strap of Cummerbund Inserted in Back Carrier	WP 0014-4
Figure 7. Insert Snap End through Inside Metal Ring.....	WP 0014-4

Figure 8. Left Cummerbund Assembly Attached to Back Carrier	WP 0014 -5
Figure 9. Back Carrier with Cummerbund Assembly Installed	WP 0014 -5
Shoulder Strap Replace	WP 0015
Figure 1. Pulling Out the Quick Release Cable	WP 0015 -1
Figure 2. Detaching Shoulder Strap from Back Carrier Buckle	WP 0015 -2
Figure 3. Insert Cable End through Hole in Cable Release Pocket	WP 0015 -2
Figure 4. Attaching Shoulder Strap to Back Carrier.....	WP 0015 -3
Figure 5. Inserting Shoulder Strap through Tri-Glide Slide on Front Carrier	WP 0015 -4
Figure 6. Threading the Cable through the Shoulder Strap Loop (Interior View).....	WP 0015 -4
Quick Release Cable Replace.....	WP 0016
Figure 1. Pulling Out Quick Release Cable	WP 0016 -1
Quick Release Buckle Replace	WP 0017
Figure 1. Inserting Quick Release Buckle through Metal Ring	WP 0017 -1
Figure 2. Threading the Cable through the Quick Release Buckle.....	WP 0017 -2
Soft Ballistic Insert Replace	WP 0018
Figure 1. Opening Pocket for Soft Ballistic Insert	WP 0018 -1
Figure 2. Inserting Soft Ballistic into Front Carrier	WP 0018 -2
Hard Armor Plates Inspect, Repair	WP 0019
Figure 1. Inspect Plates	WP 0019 -1
Fabric Repair	WP 0020
Figure 1. Straight Stitch.....	WP 0020 -1
Figure 2. Edge Sew.....	WP 0020 -2
Figure 3. Turn Edge Under and Sew	WP 0020 -2
Preparation for Storage and Shipment.....	WP 0021

Chapter 5 – Supporting Information for Soldier Plate Carrier System

References WP 0022

Components of End Item (COEI) and Basic Issue Items (BII) Lists WP 0023

 Table 1. Components of End Item (COEI) List WP 0023-3

 Table 2. Basic Issue Items (BII) List WP 0023-3

Additional Authorization List WP 0024

 Table 1. Additional Authorization List..... WP 0024-3

Expendable and Durable Items List..... WP 0025

 Table 1. Expendable and Durable Items List..... WP 0025-3

HOW TO USE THIS MANUAL

HOW TO OBTAIN TECHNICAL MANUALS

When a new system is introduced to the Army inventory, it is the responsibility of the receiving units to notify and inform the Unit Publications Clerk that a Technical Manual is available for the new system. Throughout the life cycle of the new system, the Publications Proponent will also provide updates and changes to the Technical Manual.

To receive new Technical Manuals or change packages to existing Technical Manuals (TM) for fielded equipment, provide the Unit Publications Clerk the full Technical Manual number, title, date of publication, and number of copies required. The Unit Publications Clerk will justify the request through the Unit Publications Officer. When the request is approved, the Unit Publications Clerk will use DA Form 12-R to order the series of Technical Manuals from the Army Publishing Directorate (APD).

Complete information for obtaining Army publications can be found in DA PAM 25-33.

Organization of This Manual

In this manual, primary chapters appear in upper case/capital letters; work packages are presented in numeric sequence, e.g., 0001, 0002; paragraphs within a work package are not numbered and are presented in a titled format. For a first level paragraph, titles are in all bold, upper case, capital letters, e.g., **FRONT MATTER**. Subordinate paragraph titles will have the first letter of the first word of each principle word all upper case, capital letters, all bold, e.g., **Manual Organization and Page Numbering System**. The location of additional material that must be referenced is clearly marked. Illustrations supporting maintenance procedures/text are located underneath, or as close as possible to, their referenced paragraph. Notes, Cautions, and Warning are located directly above the procedure to which they apply.

FRONT MATTER. Front matter consists of front cover, warning summary, title block, table of contents, and how to use this manual page.

CHAPTER 1 – GENERAL INFORMATION, EQUIPMENT DESCRIPTION, AND THEORY OF OPERATION. Chapter 1 contains introductory information on the Soldier Plate Carrier System as well as theory of operation.

CHAPTER 2 – OPERATOR INSTRUCTIONS. Chapter 2 contains information on assembling, donning, doffing and operating the Soldier Plate Carrier System.

CHAPTER 3 – PREVENTIVE MAINTENANCE CHECKS AND SERVICES. Chapter 3 identified preventive maintenance checks and services information.

HOW TO USE THIS MANUAL – CONTINUED

CHAPTER 4 – MAINTENANCE INSTRUCTIONS. Chapter 4 provides maintenance procedures, preparations for storage and shipment authorized at the service level.

CHAPTER 5 – SUPPORTING INFORMATION. Chapter 5 contains references, Components of End Items List (COEI), Basic Issue Items List (BII), Additional Authorization List, and Expendable and Durable Items List.

REAR MATTER. Rear matter consists of DA Form 2028, authentication page, and back cover.

Manual Organization and Page Numbering System. The manual is divided into eight major chapters that detail the topics mentioned above. Within each chapter are work packages covering a wide range of topics. Each work package is numbered sequentially starting at page 1. The work package has its own page numbering scheme and is independent of the page numbering used by other work packages. Each page of a work package has a page number of the form XXXX-YY where XXXX is the work package number (e.g. 0010 is work package 10) and YY represents the number of the page within that work package. A page number such as 0010-1/2 blank means that page 1 contains information but page 2 of that work package has been intentionally left blank.

Finding Information. The table of contents permits the reader to find information in the manual quickly. The reader should start here first when looking for a specific topic. The table of contents lists the topics, figures, and tables contained within each chapter and the work package sequence number where it can be found.

WARNINGS, CAUTIONS, AND NOTES

A warning identifies a clear danger to the person doing that procedure.

A caution identifies risk of damage to the equipment.

A note is used to highlight essential procedures, conditions, or statements or convey important instructional data to the user.

CHAPTER 1

**GENERAL INFORMATION, EQUIPMENT DESCRIPTION,
AND THEORY OF OPERATION
FOR
SOLDIER PLATE CARRIER SYSTEM**

**OPERATOR MAINTENANCE
SOLDIER PLATE CARRIER SYSTEM
DESCRIPTION AND USE OF OPERATOR CONTROLS AND INDICATORS**

SCOPE

This technical manual provides operator instructions for the soldier plate carrier system, the hard armor protective inserts for the sides, front, and back, and ancillary equipment of the soldier plate carrier system.

MAINTENANCE FORMS, RECORDS, AND REPORTS

Department of the Army forms and procedures used for equipment maintenance will be those prescribed by (as applicable) DA PAM 750-8, The Army Maintenance Management System (TAMMS) Users Manual; DA PAM 738-751, Functional Users Manual for the Army Maintenance Management Systems – Aviation (TAMMS-A); or AR 700-138, Army Logistics Readiness and Sustainability.

REPORTING EQUIPMENT IMPROVEMENT RECOMMENDATIONS (EIR)

If your plate carrier needs improvement, let us know. Send us an EIR. You, the user, are the only one who can tell us what you do not like about your equipment. Let us know why you do not like the design or performance. If you have Internet access, the easiest and fastest way to report problems or suggestions is to follow the instructions and links below:

For ALL non-Aviation/Missile Warranty, EIR and PQDRs, submit through the Web Product Quality Deficiency Reporting (PQDR) site. The Web PQDR Web site is:
https://www.pdrep.csd.disa.mil/pdrep_files/report_tools/pqdr.htm.

New accounts can be established at the following address:
https://www.pdrep.csd.disa.mil/pdrep_files/accessforms/useraccess.htm.

You may also submit your information using an SF 368 (Product Quality Deficiency Report). You can send your SF 368 using e-mail, regular mail, or fax using the addresses/fax numbers specified in (DA PAM 750-8, The Army Maintenance Management System (TAMMS) Users Manual OR DA PAM 738-75. We will send you a reply.

CORROSION PREVENTION AND CONTROL (CPC)

Corrosion Prevention and Control (CPC) of Army materiel is a continuing concern. It is important that any corrosion problems with any items be reported so that the problem can be corrected and improvements can be made to prevent the problem in future items.

Plastics, composites, and rubbers can also degrade. Degradation is caused by thermal (heat), oxidation (oxygen), solvation (solvents), or photolytic (light, typically UV) processes. The most common exposures are excessive heat or light. Damage from these processes will appear as cracking, softening, swelling, and/or breaking.

CORROSION PREVENTION AND CONTROL (CPC) – CONTINUED

SF Form 368, Product Quality Deficiency Report should be submitted to the address specified in DA PAM 750-8, The Army Maintenance Management System (TAMMS) Users Manual.

DESTRUCTION OF ARMY MATERIEL TO PREVENT ENEMY USE

Destruction of Army materiel to prevent enemy use shall be in accordance with TM 750-244-1-2.

PREPARATION FOR STORAGE AND SHIPMENT

Refer to WP 0018 for storage and shipping procedures.

NOMENCLATURE CROSS REFERENCE LIST

Table 1. Nomenclature Cross-Reference List.

COMMON NAME	OFFICIAL NOMENCLATURE
100 mile-per-hour Tape	Pressure Sensitive Adhesive Tape
Duct Tape	Pressure Sensitive Adhesive Tape
Hard Armor Protective Inserts	Small Arms Protective Inserts
Hard Armor Protective Inserts	Enhanced Small Arms Protective Inserts
Hard Armor Protective Inserts	X-Small Arms Protective Inserts
Hard Armor Protective Inserts	Enhanced Side Ballistic Inserts
Hard Armor Protective Inserts	X-Side Ballistic Inserts
Hook and Loop Fastener	Hook and Pile Fastener
Rigger's Tape	Pressure Sensitive Adhesive Tape
Plate Carrier	Soldier Plate Carrier System

LIST OF ABBREVIATIONS AND ACRONYMS

Table 2. List Of Abbreviations and Acronyms.

ABBREVIATION / ACRONYM	DEFINITION
2XL	Extra Extra Large
AAL	Additional Authorization List
APD	Army Publishing Directorate
BII	Basic Issue Item
BT	Bottle
CAGEC	Commercial and Government Entity Code
CBRN	Chemical, Biological, Radiological, and Nuclear
COEI	Component of End Item
EA	Each
EIR	Equipment Improvement Recommendation

LIST OF ABBREVIATIONS AND ACRONYMS – CONTINUED

Table 2. List Of Abbreviations and Acronyms – Continued.

ABBREVIATION / ACRONYM	DEFINITION
ESAPI	Enhanced Small Arms Protective Inserts
ESBI	Enhanced Side Ballistic Inserts
FM	Field Manual
ft	Foot
KT	Kit
lb	Pound(s)
MOLLE	Modular Lightweight Load-Carrying Equipment
NIIN	National Item Identification Number
NSN	National Stock Number
OCP	Operation Enduring Freedom (OEF) camouflage pattern
OEF	Operation Enduring Freedom
PK	Pack
P/N	Part Number
PMCS	Preventive Maintenance Checks and Services
PQDR	Product Quality Deficiency Reporting
RL	Roll
SAPI	Small Arms Protective Inserts
SPC	Side Plate Carrier
SPCS	Soldier Plate Carrier System
SF	Standard Form
TAMMS	The Army Maintenance Management System
TAP	Tactical Assault Panel
TM	Technical Manual
UCP	Universal Camouflage Pattern
U/I	Unit of Issue
WP	Work Package
XS	Extra-Small
S	Small
SE	Set
M	Medium
ML	Medium-Long
L	Large
XL	Extra Large
XSAPI	X-Small Arms Protective Inserts
XSBI	X-Side Ballistic Insert

END OF WORK PACKAGE

**OPERATOR MAINTENANCE
SOLDIER PLATE CARRIER SYSTEM
EQUIPMENT DESCRIPTION AND DATA**

EQUIPMENT CHARACTERISTICS, CAPABILITIES, AND FEATURES

The plate carrier system is a modular system that consists of a vest, soft ballistic inserts, and hard armor plates. There are three configurations and two camouflage patterns: universal camouflage pattern (UCP) and Operation Enduring Freedom (OEF) camouflage pattern (OCP). Table 1 shows the differences between models.

Base Vest Assembly

The plate carrier system consists of a front carrier (Figure 1), a back carrier (Figure 6), shoulder straps (Figure 9), and right and left side plate carriers (Figure 10), held together by nylon webbing, plastic buckles, and a cable release assembly (Figures 3 and 13). The vest requires four soft ballistic inserts in order to provide protection to the Soldier: one in the front, one in the back, and one on each side.

The plate carrier system may be configured without the side plate carriers when authorized by unit commanders. In this configuration, instead of side plate carriers, there is a set of attachment straps (Figure 14) that connect the front and back carriers.

Alternatively, the plate carrier system may be configured with a cummerbund assembly (Figure 15) that provides additional scalable protection on both sides. This assembly consists of a cummerbund (two pieces) and two pockets which weave onto the cummerbund. The cummerbund assembly holds a hard plastic insert, soft ballistics, and hard armor plates and attaches to the front and back carriers.

Hard Armor

There are two types of hard armor, side ballistic inserts and front/back ballistic inserts. These are either Enhanced Small Arms Protective Inserts (ESAPI) (Figure 18) and Enhanced Side Ballistic Inserts (ESBI) (Figure 19), or X-Small Arms Protective Inserts (XSAPI) and X-Side Ballistic Inserts (XSBI). The ESAPI/XSAPI inserts provide additional levels of protection to the front and back of the Soldier. The ESBI/XSBI inserts provide additional levels of protection to the sides of the Soldier's torso.

Interoperability

The plate carrier is compatible with Modular Lightweight Load-carrying Equipment (MOLLE) components.

LOCATION AND DESCRIPTION OF MAJOR COMPONENTS

Base Vest Assembly

NOTE

The term “interior fabric” or “interior surface” refers to the side of any component of the plate carrier system that faces the Soldier when worn. The term “exterior fabric” or “exterior surface” means the side of any component of the plate carrier system that faces away from the Soldier. The term “inside surface,” “inside fabric” or “inside” means the area of any plate carrier component that is between the exterior and interior surfaces. The inside or inside surface of a plate carrier component is the portion that touches the soft ballistic.

Front Carrier. The front carrier (Figure 1) is a camouflage outer shell that holds a soft ballistic insert and an ESAPI/XSAPI plate. It is attached to the shoulder straps using the quick-release cable and hook and loop fastener. In the center of the neckline is a pocket for storage of the pull tab for the quick-release cable assembly, which is secured with hook and loop fastener. MOLLE webbing is sewn on the vest for attaching items such as MOLLE pouches.



Figure 1. Front Carrier Exterior.

LOCATION AND DESCRIPTION OF MAJOR COMPONENTS – CONTINUED

The top layer of fabric of the front carrier is secured on the underside using hook and loop fastener tape. Lifting this fabric exposes the ESAPI/XSAPI pocket (Figure 2) and allows access to the channels where the quick-release cable is threaded through the shoulder strap webbing and side plate carrier buckles (Figure 3).



Figure 2. Opening the Front Carrier.

LOCATION AND DESCRIPTION OF MAJOR COMPONENTS – CONTINUED

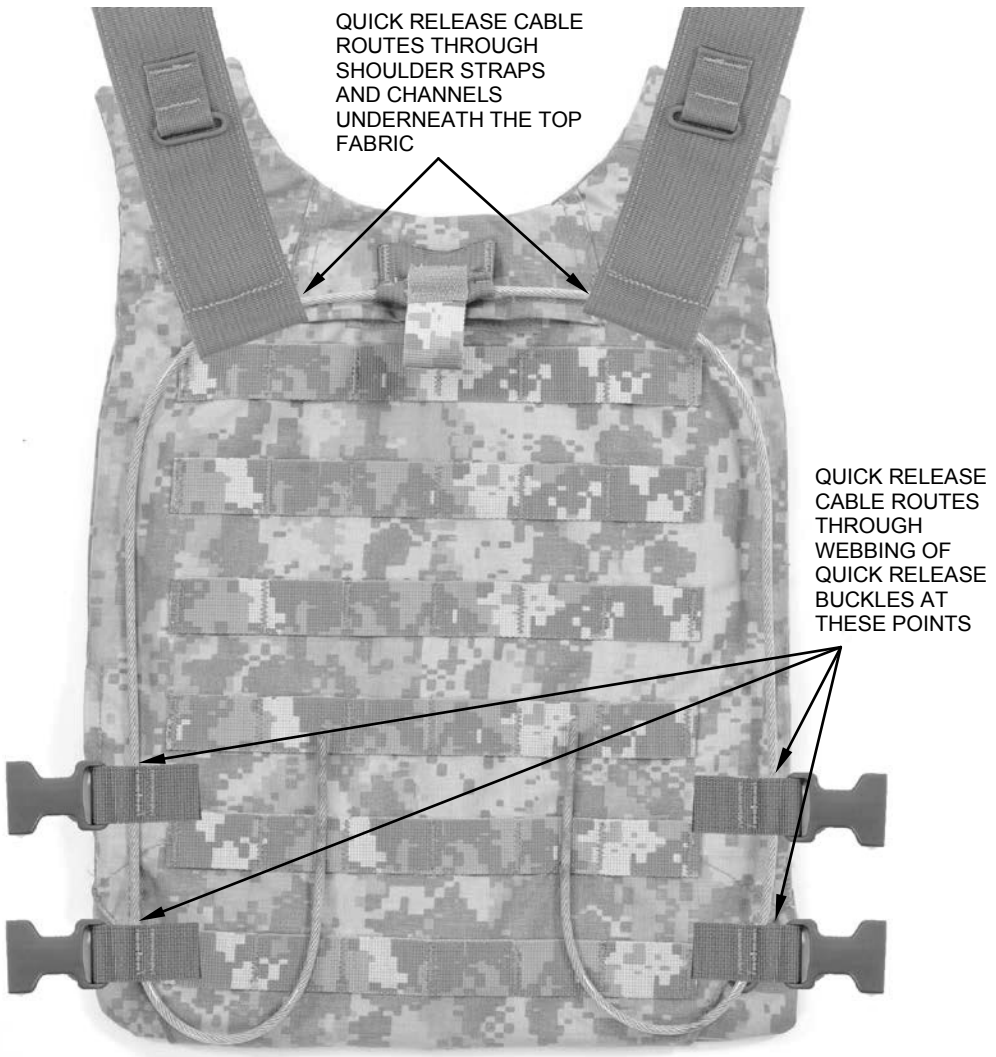

Figure 3. Quick Release Cable Routing (Interior of Front Carrier with Components Shown for Clarity) – Side Plate Carrier Configuration.

LOCATION AND DESCRIPTION OF MAJOR COMPONENTS – CONTINUED

The interior of the front carrier (Figure 4) provides access to the front soft ballistic insert pocket. The data label is also located on the interior of the front carrier.



Figure 4. Front Carrier Open for Soft Ballistic Insert.

Quick Release Buckles. The four female quick-release buckles (Figure 5) connect the side plate carriers to the front carrier (or, in the non-side-plate-carrier configuration, they connect the straps from the back carrier to the front carrier). The buckles are attached to the front carrier by the quick-release cable. For the cummerbund configuration the female buckles are replaced with four male quick release buckles (Figure 5).



Female Quick Release Buckle



Male Quick Release Buckle

Figure 5. Quick Release Buckles.

LOCATION AND DESCRIPTION OF MAJOR COMPONENTS – CONTINUED

Back Carrier. The back carrier (Figure 6) is a camouflage outer shell that holds a soft ballistic insert and an ESAPI/XSAPI plate. On the upper portion of the back carrier inside surface are the attachment points for the shoulder straps. There is a casualty drag strap located on the upper center portion of the back carrier exterior.

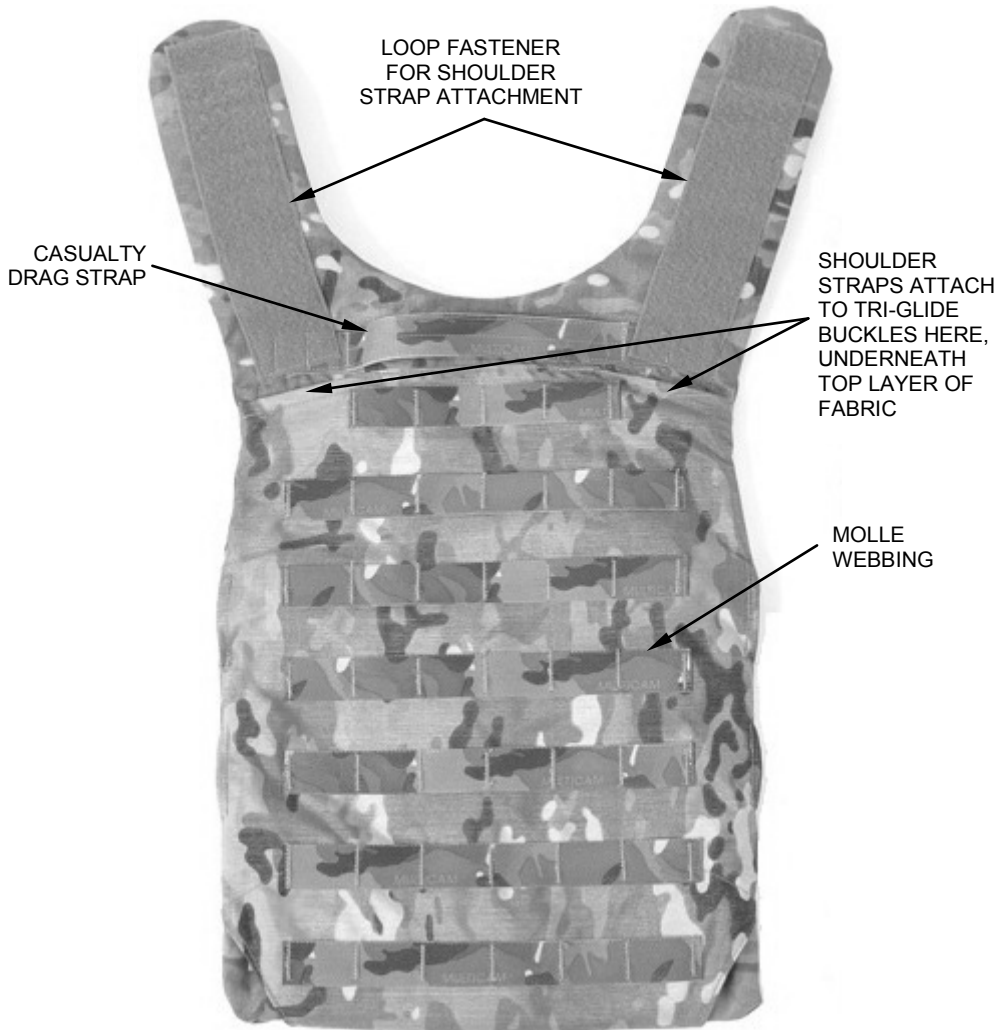

Figure 6. Back Carrier Exterior.

LOCATION AND DESCRIPTION OF MAJOR COMPONENTS – CONTINUED

The top layer of fabric of the back carrier is secured on the underside using hook and loop fastener tape in a similar manner to the front carrier. Lifting this fabric (Figure 7) exposes the back ESAPI/XSAPI pocket and allows access to the shoulder strap adjustment buckles, the cummerbund adjustment straps, the side plate carrier rear adjustment straps, and D-rings for the side plate carrier angle straps.



Figure 7. Opening the Back Carrier.

LOCATION AND DESCRIPTION OF MAJOR COMPONENTS – CONTINUED

The interior of the back carrier (Figure 8) provides access to the back soft ballistic insert pocket. The data plate containing essential information is also located on the inside of the back carrier.



Figure 8. Back Carrier Interior Open for Soft Ballistic Insert.

LOCATION AND DESCRIPTION OF MAJOR COMPONENTS – CONTINUED

Shoulder Straps. The two shoulder straps (Figure 9) connect the front and back carriers. They attach to the front carrier using the cable release system and to the back carrier using buckles and hook and loop fastener.

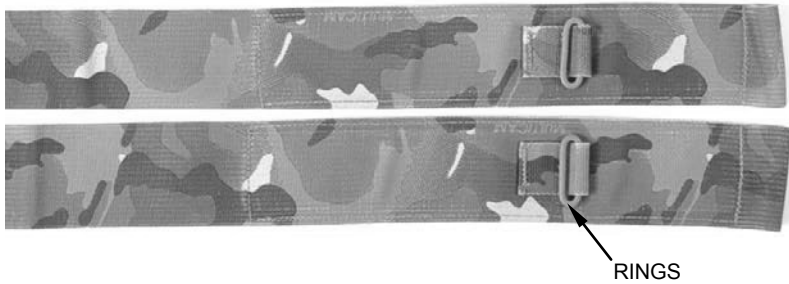

Figure 9. Shoulder Straps.

Side Plate Carriers. Left and right side plate carriers (Figure 10) connect the front and back carriers. They carry the ESBI/XSBI plates and soft ballistic inserts.

The side plate carriers attach to the front carrier using plastic buckles as part of the quick-release system and to the back carrier with three separation strap assemblies of nylon webbing through tri-glide buckles on the carrier.

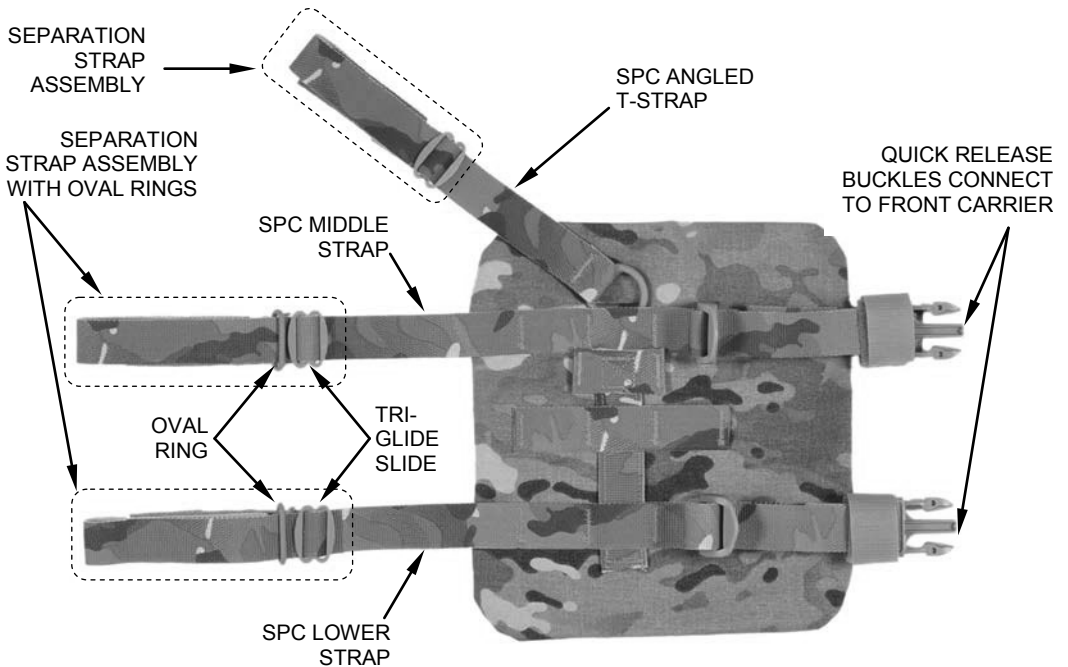

Figure 10. Right Side Plate Carrier Exterior.

LOCATION AND DESCRIPTION OF MAJOR COMPONENTS – CONTINUED

The interior of the side plate carrier (Figure 11) provides access to the carrier for the soft ballistic insert and ESBI/XSBI. The data label containing essential information is also located on the interior of the side plate carrier.

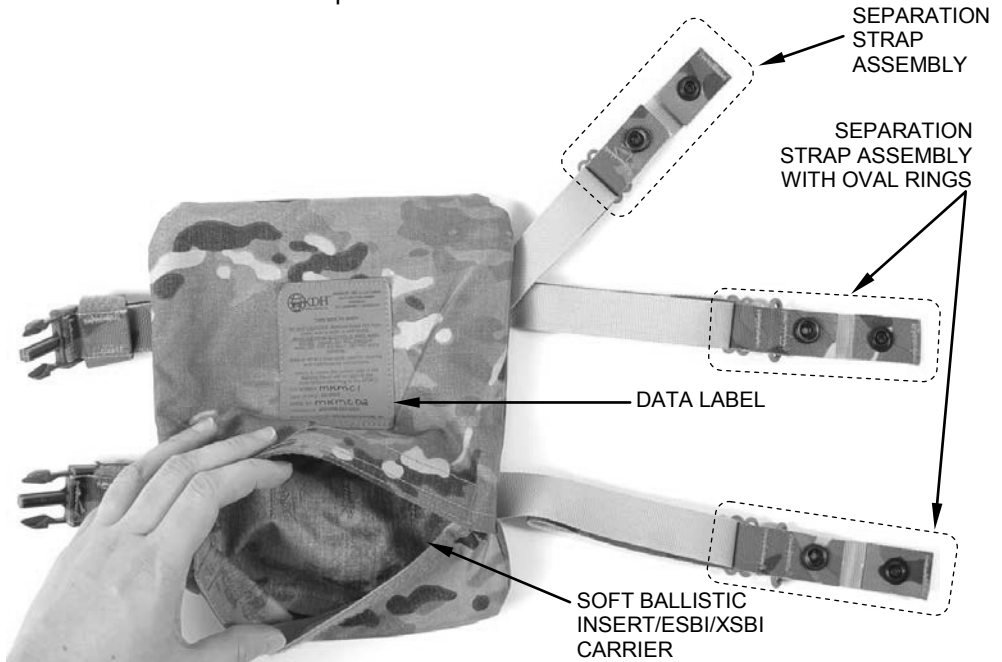

Figure 11. Right Side Plate Carrier with Pocket for ESBI/XSBI Open.

The angled T-strap (Figure 12) is detachable and used to attach the side plate carriers (side plate carrier configuration) and the cummerbund (cummerbund configuration) to the back carrier.



Figure 12. Angled T-Strap with Separation Strap Assembly Attached.

LOCATION AND DESCRIPTION OF MAJOR COMPONENTS – CONTINUED

Cable Release Assembly. The cable release assembly (Figure 13) is a single cable with a center pull-tab of nylon webbing that can be pulled to separate and release the front and back carrier quickly.

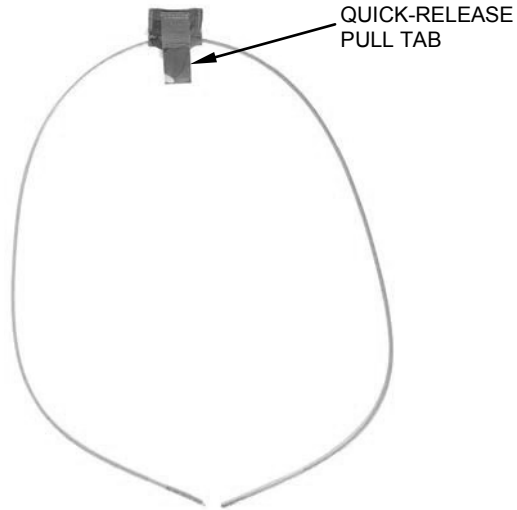

Figure 13. Cable Release Assembly.

Attachment Straps. Four attachment straps are used in the non-side plate carrier configuration to connect the front carrier to the back carrier (Figure 14). These are used in place of the side plate carriers or cummerbund.



Figure 14. Attachment Strap.

LOCATION AND DESCRIPTION OF MAJOR COMPONENTS – CONTINUED

Cummerbund and Side Plate Pockets. The cummerbund assembly connects to the back carrier and includes a cummerbund and attachable side plate pockets (Figure 15). The cummerbund holds a hard plastic stiffener and a soft ballistic insert. The side plate pockets, which can hold hard and soft ballistics, attach to the inside of the cummerbund.

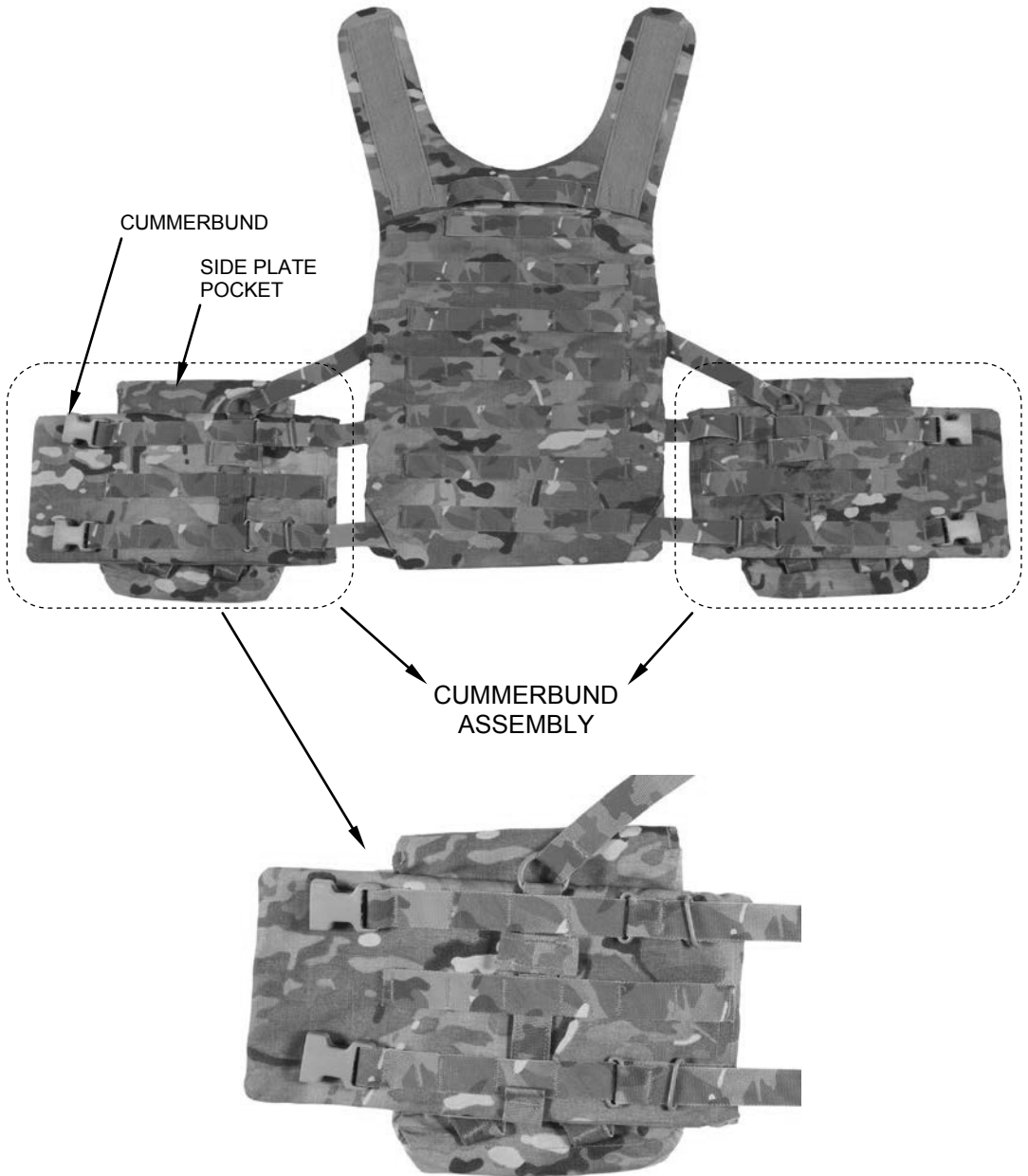

Figure 15. Back Carrier with Cummerbund and Side Plate Pockets.

LOCATION AND DESCRIPTION OF MAJOR COMPONENTS – CONTINUED

Soft Ballistic Inserts. The two soft ballistic inserts in Figure 16 are located inside the front and back carriers. The two ballistic inserts in Figure 17 are placed in the side plate carriers or side plate pockets. The inserts for the cummerbund include the hard plastic stiffener and the soft ballistic insert. All soft ballistic inserts have rip stop ballistic covers over an internal ballistic core. The front and back inserts (Figure 16) are identical, as are the inserts for the side plate carriers/side plate pockets (Figure 17), and cummerbund. Each soft ballistic insert has a data label.



Figure 16. Vest Soft Ballistic Insert.



Figure 17. Side Soft Ballistic Insert.

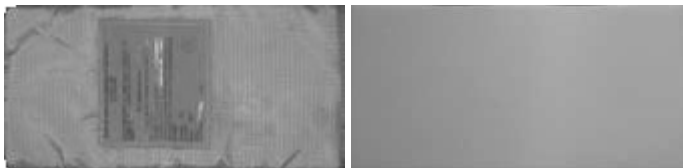

Figure 18. Cummerbund Soft Ballistic Insert and Plastic Stiffener.

LOCATION AND DESCRIPTION OF MAJOR COMPONENTS – CONTINUED**Hard Armor****NOTE**

There are two types of hard armor plates: ESAPI/XSAPI and ESBI/XSBI. The XSAPI and XSBI have tan covers, whereas the ESAPI and ESBI have green covers. They have the same dimensions, but the XSAPI and XSBI are slightly heavier. The XSAPI and XSBI provide protection against a wider variety of ballistic threats. Use of ESAPI and ESBI or XSAPI and XSBI is determined by mission requirements.

ESAPI/XSAPI. The two ESAPI/XSAPI (Figure 19) provide protection for the chest and back against armor piercing bullets. The concave side is worn toward the body.



Figure 19. Hard Armor Plates (ESAPI Shown).

LOCATION AND DESCRIPTION OF MAJOR COMPONENTS – CONTINUED

ESBI/XSBI. The two ESBI/XSBI (Figure 20) provide side protection against armor piercing bullets. The concave side is worn toward the body.

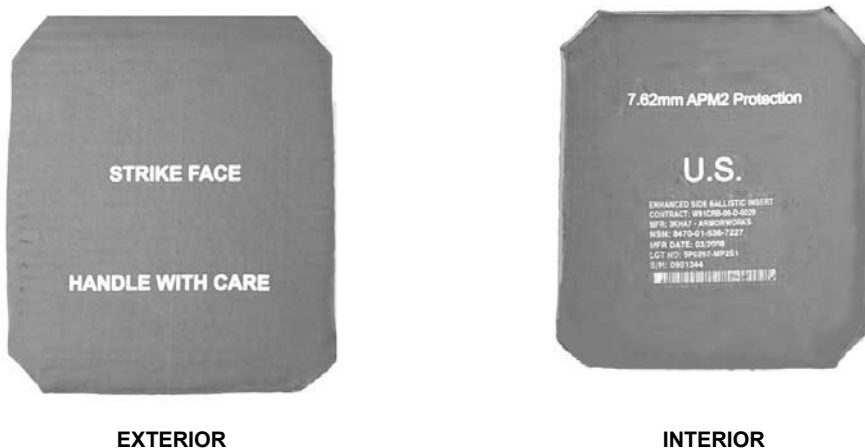
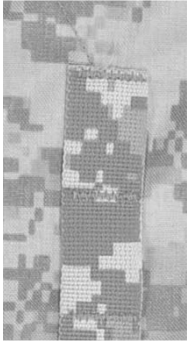
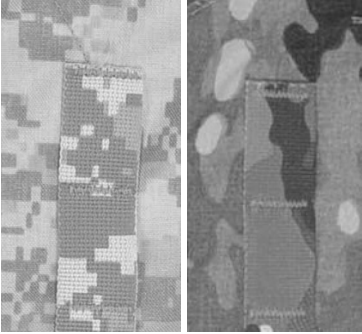
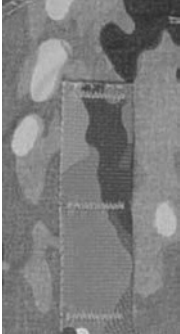

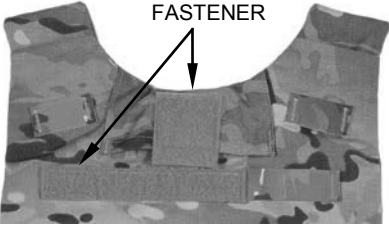
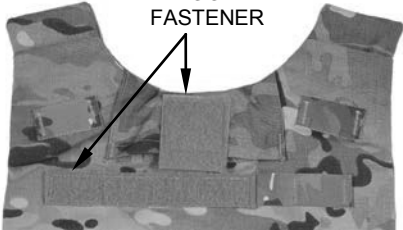

Figure 20. Side Hard Armor Plates (ESBI Shown).

DIFFERENCES BETWEEN MODELS

Refer to Table 1 for differences between the Universal Camouflage Pattern (UCP) plate carrier and the Operation Enduring Freedom (OEF) Camouflage Pattern plate carrier.

Table 1. Differences between Models.

Non-Side Plate Carrier Configuration	Side Plate Carrier (SPC) Configuration	Cummerbund Configuration
 <p data-bbox="411 753 509 773">UCP Only</p>	 <p data-bbox="833 753 975 773">UCP and OCP</p>	 <p data-bbox="1334 753 1432 773">OCP Only</p>
 <p data-bbox="325 1063 596 1083">No loop fastener for insignia</p>	 <p data-bbox="853 798 971 841">LOOP FASTENER</p> <p data-bbox="784 1063 1024 1083">Loop fastener for insignia</p>	 <p data-bbox="1332 798 1450 841">LOOP FASTENER</p> <p data-bbox="1263 1063 1503 1083">Loop fastener for insignia</p>

DIFFERENCES BETWEEN MODELS – CONTINUED

Table 1. Differences between Models – Continued.

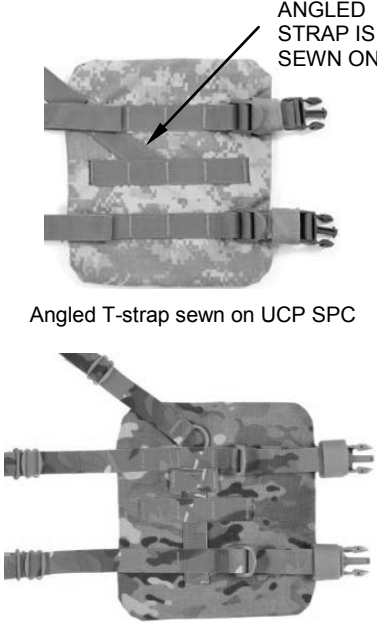
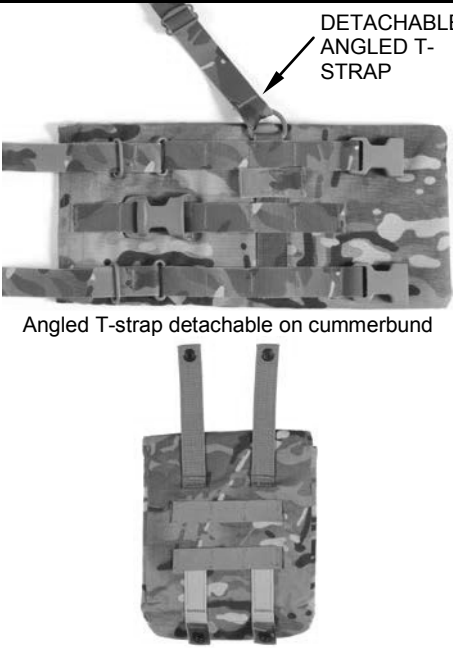
Non-Side Plate Carrier Configuration	Side Plate Carrier Configuration	Cummerbund Configuration
 <p data-bbox="371 622 546 647">Attachment straps</p>	 <p data-bbox="986 317 1106 388">ANGLED T-STRAP IS SEWN ON</p> <p data-bbox="738 622 1066 647">Angled T-strap sewn on UCP SPC</p> <p data-bbox="713 972 1095 997">Angled T-strap detachable on OCP SPC</p>	 <p data-bbox="1470 317 1590 388">DETACHABLE ANGLED T-STRAP</p> <p data-bbox="1175 622 1590 647">Angled T-strap detachable on cummerbund</p> <p data-bbox="1179 972 1587 997">Side plate pocket attaches to cummerbund</p>



0002-17

TM 10-8470-209-10

0002

DIFFERENCES BETWEEN MODELS – CONTINUED

Table 1. Differences between Models – Continued.

Non-Side Plate Carrier Configuration	Side Plate Carrier Configuration	Cummerbund Configuration
 <p data-bbox="293 476 566 496">Female quick release buckle</p>	 <p data-bbox="737 476 1010 496">Female quick release buckle</p>	 <p data-bbox="1230 476 1481 496">Male quick release buckle</p>

0002-18

TM 10-8470-209-10

0002

EQUIPMENT DATA

Component	Data
Vest (Front and Back Carrier)	
Sizes.....	XS, S, M, L, XL, 2XL
Set, Left and Right Shoulder Straps	
Sizes.....	XS, S, M, L, XL, 2XL
Right Side Plate Carrier	
Sizes.....	XS-MED, L-XL, 2XL
Left Side Plate Carrier	
Sizes.....	XS-MED, L-XL, 2XL
Set, Cummerbund	
Sizes.....	XS-S, MED-L, XL-2XL
Set, Side Plate Pockets	
Sizes.....	Universal Size
Cable Release Assembly	
Sizes.....	Universal Size
Buckles, Quick Release (Set of 4)	
Sizes.....	Universal Size
Hard Armor Ballistic Inserts	
ESBI/XSBI	
Sizes.....	Universal Size
Dimensions	7 inches by 8 inches
ESAPI/XSAPI	
Sizes.....	XS, S, M, L, XL
Dimensions (XS)	7.25 inches by 11.50 inches
Dimensions (S)	8.75 inches by 11.75 inches
Dimensions (M)	9.50 inches by 12.50 inches
Dimensions (L)	10.25 inches by 13.25 inches
Dimensions (XL)	11.0 inches by 14.0 inches

EQUIPMENT DATA – CONTINUED

System Weight

Table 2. Soldier Plate Carrier System Weight Chart (in pounds).*

Configuration	XS	S	M	L	XL	2XL
Non-Side Plate Configuration (front and back carriers with attachment straps)	3.64	4.08	4.37	4.94	5.28	5.32
Side Plate Configuration (front, back, and side plate carriers)	5.46	5.90	6.19	6.84	7.18	7.22
Cummerbund Configuration (front and back carriers, cummerbund, and side plate pocket)	6.62	7.06	7.79	8.36	9.12	9.17

*Weights include all soft ballistics

END OF WORK PACKAGE

OPERATOR MAINTENANCE
SOLDIER PLATE CARRIER SYSTEM
THEORY OF OPERATION

THEORY OF OPERATION

The Soldier plate carrier system is designed to protect the Soldier from small-arms fire as well as fragmentation. It is intended to increase mobility and maneuverability by lightening the Soldier's load when operating on foot in mountainous terrain or at high altitude. Different field scenarios will require different levels of protection for the Soldier. Unit commanders will determine the level of protection required for each mission and which configuration will best meet that need. See WP 0004, Table 1 for the complete plate carrier Inventory.

Configurations

Non-Side-Plate Carrier Configuration

The most basic configuration of the plate carrier consists of the front and rear carriers with soft ballistic inserts, two shoulder straps, four attachment straps, four quick release buckles, and the quick release cable (Figure 1). The side plate carriers are not worn in this configuration.

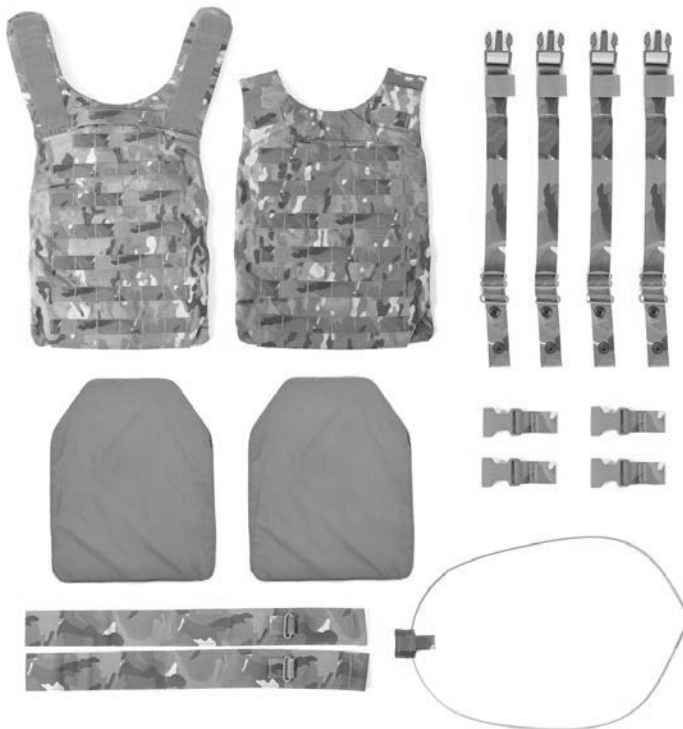

Figure 1. Plate Carrier Basic Inventory (Non-Side-Plate Carrier Configuration).

THEORY OF OPERATION – CONTINUED**Side Plate Carrier Configuration**

For increased protection, left and right side plate carriers with soft ballistic inserts can be added to the basic inventory.

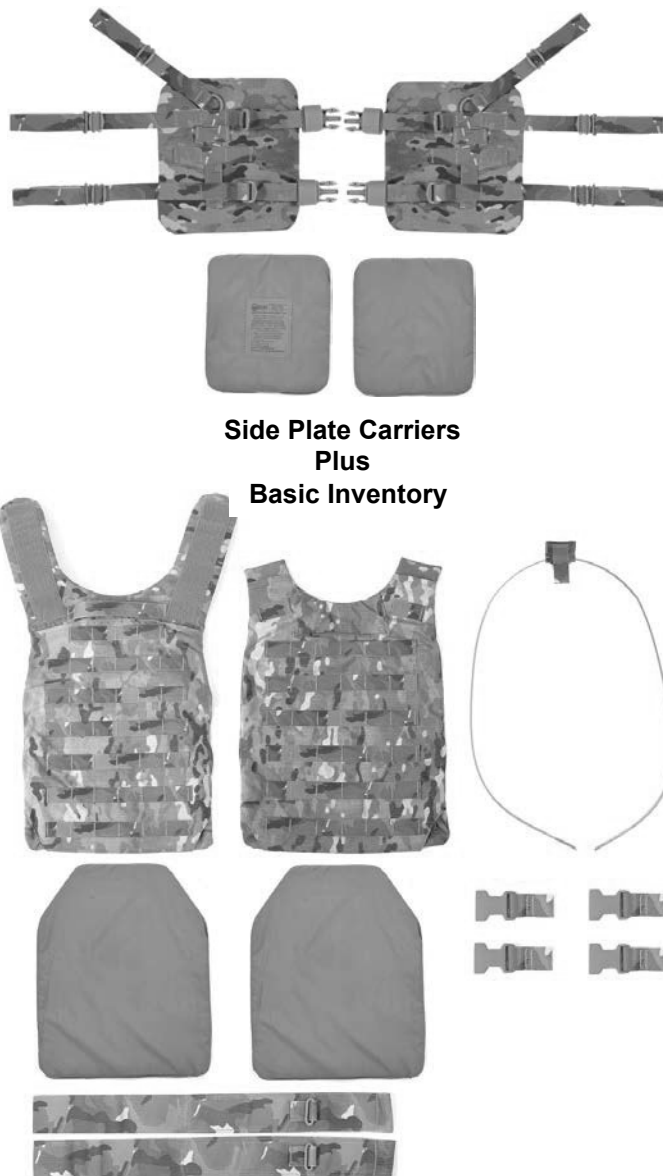

Figure 2. Basic Inventory with Side Plate Carriers (Side Plate Carrier Configuration).

THEORY OF OPERATION – CONTINUED**Cummerbund Configuration**

An alternate cummerbund configuration adds a cummerbund with soft ballistic and hard plastic inserts and side plate pockets with soft ballistic inserts to the basic inventory.

**Cummerbund Assembly
with Side Plate Pocket****Plus
Basic Inventory**

Figure 3. Basic Inventory with Cummerbund Assembly (Cummerbund Configuration).

THEORY OF OPERATION – CONTINUED**Soldier Plate Carrier System (SPCS) Configurations with Hard Armor Plates**

For the highest level of protection, you can install contoured hard armor plates (Figure 4), which protect the vital organs against multiple small arms rifle bullets and indirect fire flechettes. Leave the soft ballistic protection in the SPCS when installing the hard armor and ensure the soft ballistic protection remains flat and smooth. Install soft ballistics to the side of the hard armor that is closest to the body.



Figure 4. Hard Armor Plates.

As shown in Figure 5, the most complete inventory for the SPCS side plate carrier configuration consists of the front and rear carriers with soft ballistic inserts and ESAPI/XSAPI plates, two shoulder straps, the left and right side plate carriers with soft ballistic inserts and ESBI/XSBI plates, four quick release female buckles, and the quick release cable.

THEORY OF OPERATION – CONTINUED

NOTE

The angled t-straps of the earlier side plate carriers are permanently attached to the side plate carriers. More recent side plate carriers have detachable angled t-straps, as shown in Figure 5.

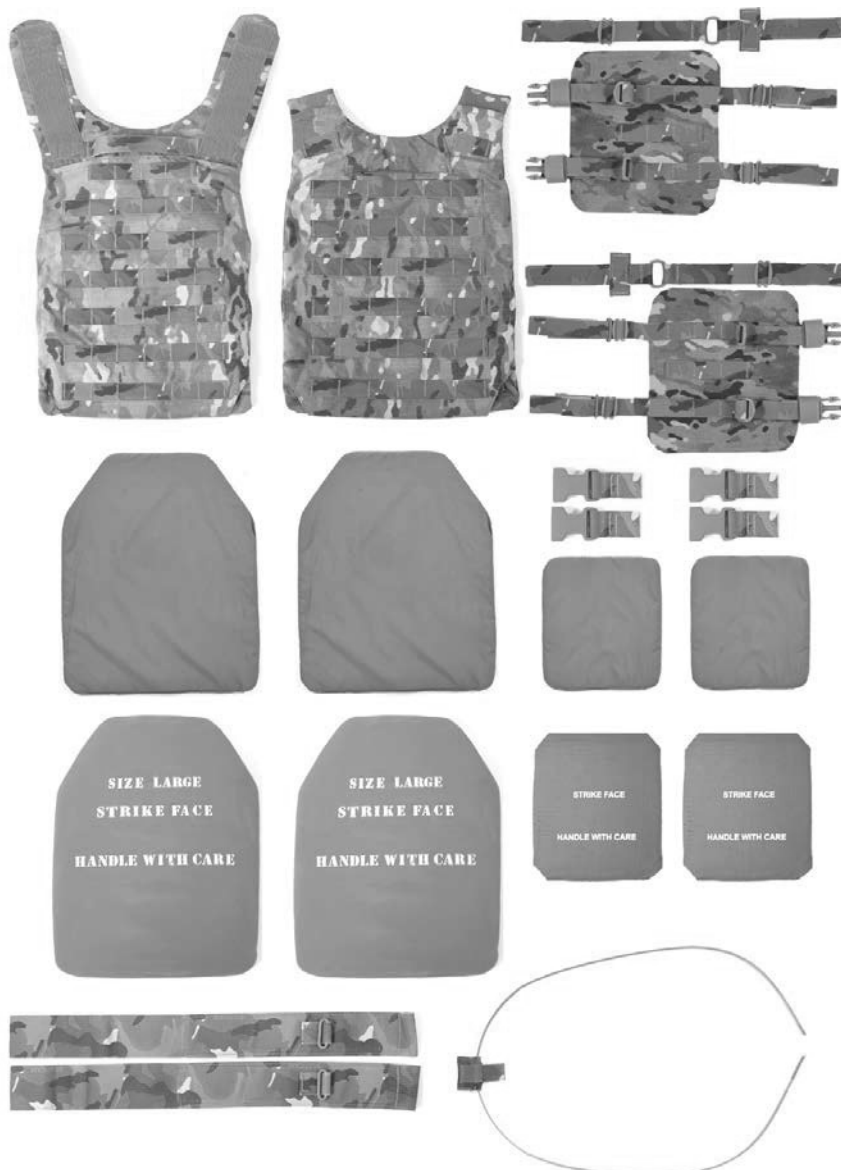

Figure 5. Inventory of Side Plate Carrier Configuration with Hard Armor Plates.

THEORY OF OPERATION – CONTINUED

As shown in Figure 6, the most complete inventory for the SPCS cummerbund configuration consists of the front and rear carriers with soft ballistic inserts and ESAPI/XSAPI plates, two shoulder straps, the cummerbund with plastic stiffener, soft ballistic inserts, and angled t-straps, side plate pockets with soft ballistic inserts and ESBI/XSBI plates, four quick release male buckles, and the quick release cable.

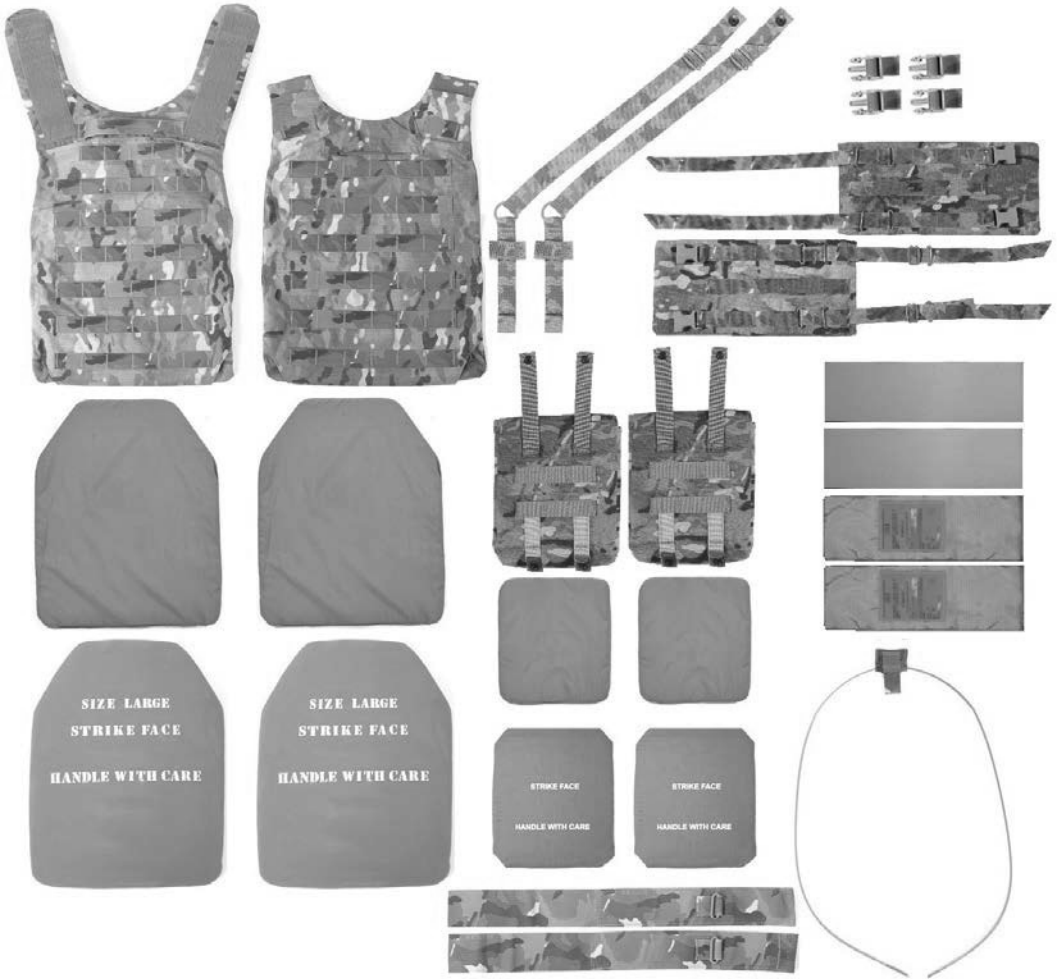

Figure 6. Inventory of Cummerbund Configuration with Hard Armor Plates.

THEORY OF OPERATION – CONTINUED

Quick-Release Tab

The plate carrier has an quick-release tab designed to be used during emergency situations only (Figure 7). With the plate carrier assembled with some or all of the accessories, the quick release tab can be pulled to doff the vest rapidly in emergency situations (see WP 0005, Doffing). Such situations could include needing quick access for medical attention or removing the vest quickly to swim.



Figure 7. Pulling the Quick Release Cable.

Once the quick-release tab has been pulled, the vest can be reassembled easily to provide continued ballistic protection.

THEORY OF OPERATION – CONTINUED**Plate Carrier System and MOLLE****WARNING**

Unbuckle either the left or right side buckles of the Tactical Assault Panel (TAP) prior to pulling the emergency release tab. Failure to do so will prevent the front and back carriers from falling away from the body completely and may result in injury.

Webbing attachments on the SPCS front carrier accommodate limited load carrying compatible with Modular Light-Weight Load Carrying Equipment (MOLLE).

END OF WORK PACKAGE

CHAPTER 2

OPERATOR INSTRUCTIONS
FOR
SOLDIER PLATE CARRIER SYSTEM

**OPERATOR MAINTENANCE
SOLDIER PLATE CARRIER SYSTEM
DESCRIPTION AND USE OF OPERATOR CONTROLS AND INDICATORS**

The Soldier Plate Carrier System is a modular system that consists of a vest assembly, side plate carriers or cummerbund assembly and hard armor that increases the area of coverage and level of protection.

There are no controls or indicators for this equipment.

END OF WORK PACKAGE

**OPERATOR MAINTENANCE
SOLDIER PLATE CARRIER SYSTEM
SIDE PLATE CARRIER CONFIGURATION
OPERATION UNDER USUAL CONDITIONS – ASSEMBLY AND DISASSEMBLY**

INITIAL SETUP

References:

WP 0002
WP 0010

ASSEMBLY AND PREPARATION FOR USE

Inventory

Proper sizing of the Soldier plate carrier system is critical to its ability to protect you from ballistic threats. This includes ensuring each component of your plate carrier is the correct size.

1. Confirm that you have the side plate carrier configuration of the Soldier plate carrier system as shown in Figure 1.





Figure 1. Soldier Plate Carrier System (Side Plate Carrier Configuration).

2. Inventory system using Table 1.
 - a. The first column lists the name of the component to be inventoried.
 - b. The second column indicates the quantity of that item required to make a complete plate carrier system.

For additional information, see WP 0002.



ASSEMBLY AND PREPARATION FOR USE – CONTINUED

Table 1. Plate Carrier Inventory (Side Plate Carrier Configuration)*.

COMPONENT	QTY	FIGURE
Front Carrier	1	
Back Carrier	1	
Shoulder Strap (on back carrier)	2	

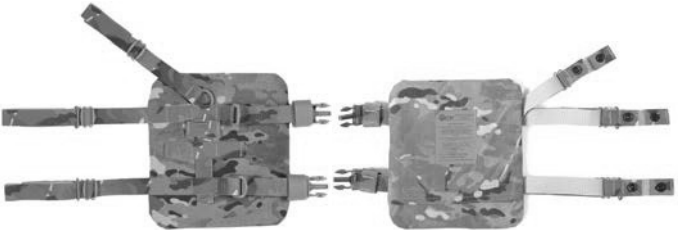
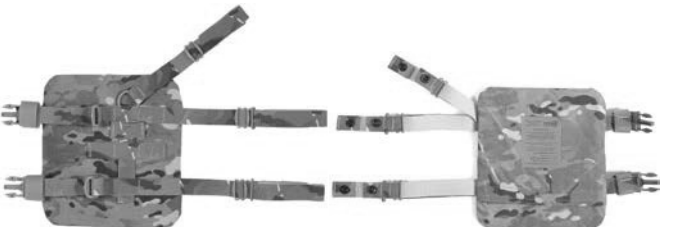

ASSEMBLY AND PREPARATION FOR USE — CONTINUED

Table 1. Plate Carrier Inventory (Side Plate Carrier Configuration)* – Continued.

COMPONENT	QTY	FIGURE
Female Quick Release Buckle (on front carrier)	4	
Cable Release Assembly (on front carrier)	1	
Attachment Strap for Non-Side-Plate-Carrier Configuration	4	
OR		
Right Side Plate Carrier (SPC) Assembly (with angled t-strap, one separation strap assembly, and one set of separation straps with oval ring)	1	
Left Side Plate Carrier (SPC) Assembly (with angled t-strap, one separation strap assembly, and one set of separation straps with oval ring)	1	

ASSEMBLY AND PREPARATION FOR USE — CONTINUED

Table 1. Plate Carrier Inventory (Side Plate Carrier Configuration)* – Continued.

COMPONENT	QTY	FIGURE
Vest Soft Ballistic Insert	2	
Side Plate Carrier Soft Ballistic Insert	2	

*Additional optional components may be included as determined by mission requirements.

3. Check the interior side of each component for a data label.
4. Ensure each component is the correct size for your system as indicated in Table 2.
 - a. On the first row, find the vest size of your plate carrier.
 - b. As you inventory each component, find that component in the left-most column of Table 2. The correct size for each component is listed at the intersection of the row for the individual component and the column for the size of your vest.
 - c. If a component is not the correct size, or if it does not have a data label, turn it in for a properly-sized component.

ASSEMBLY AND PREPARATION FOR USE – CONTINUED

Table 2. Plate Carrier Component (Side Plate Carrier Configuration) Sizing Chart.

Vest Size	XS	S	M	L	XL	2XL
Front Carrier & Soft Ballistic Insert	XS	S	M	L	XL	XL
Back Carrier & Soft Ballistic Insert	XS	S	M	L	XL	2XL
Shoulder Straps	XS	S	M	L	XL	2XL
Cable Release Assembly	U	U	U	U	U	U
Side Plate Carriers	XS-S	XS-S	XS-S	M-L	M-L	2XL
Side Plate Carrier Soft Ballistic Inserts	U	U	U	U	U	U
Non-Side-Plate Configuration Attachment Straps Set	XS-M	XS-M	XS-M	L-XL	L-XL	2XL
ESAPI/XSAPI Plates	XS	S	M	L	XL	XL
ESBI/XSBI Plates	U	U	U	U	U	U

5. Inspect each component using Table 1, WP 0010, Preventive Maintenance Checks and Services.

END OF TASK

Assemble Base Vest Assembly

WARNING

Ensure there are no kinks in the quick-release cable. Failure to do so could adversely affect the function of the quick-release, causing injury or death to personnel.

CAUTION

Ensure the sizes of the front and back carrier match by comparing data label information. Ensure the sizes of the side plate carriers match the sizes of the front and back carriers by comparing data label information. Failure to do so could affect fit.

ASSEMBLY AND PREPARATION FOR USE — CONTINUED**Assemble Base Vest Assembly – Continued****NOTE**

The terms interior fabric or interior surface is the side of any component of the plate carrier that faces the Soldier when worn. The terms exterior fabric or exterior surface mean the side of any component of the plate carrier that faces away from the Soldier.

The terms inside surface, inside fabric or inside mean the area of any plate carrier component that is between the exterior and interior surfaces. The inside or inside surface of a plate carrier component is the portion that touches the soft ballistic inserts.

1. Attach the shoulder straps to the back carrier:
 - a. Thread the 2-inch nylon webbing of the shoulder strap through the tri-glide slide on the back carrier (Figure 2).



Figure 2. Attaching Shoulder Strap to Back Carrier.

ASSEMBLY AND PREPARATION FOR USE — CONTINUED

- b. Double the strap back through the tri-glide slide to lock it before stowing the excess strap and buckle inside the back carrier (Figure 3).



Figure 3. Stowing the Shoulder Strap and Slide.

- c. Repeat steps a and b for the second strap.
2. Open the front panel of the front carrier to allow access to the cable release channels inside the carrier (Figure 4).



Figure 4. Access to Cable Release Channels.

ASSEMBLY AND PREPARATION FOR USE — CONTINUED

3. Insert the cable ends through the holes on either side of the cable release pocket (Figure 5).



Figure 5. Inserting Cable Ends through Holes in Cable Release Pocket.

4. Pull the cables through so the pull-tab is centered on the loop fastener (Figure 6).



Figure 6. Pulling Both Cables through Holes.

ASSEMBLY AND PREPARATION FOR USE — CONTINUED

5. Attach the shoulder straps to the front carrier:
 - a. Insert the looped end of the 2-inch nylon webbing of the shoulder strap through the slot on the metal tri-glide slide inside the front carrier (Figure 7).

NOTE

For Figures 7 through 10, the front carrier is shown inside-out to better illustrate the procedures. During actual assembly, most of the attachment points on the front carrier are not visible. The procedures must be performed by touch.

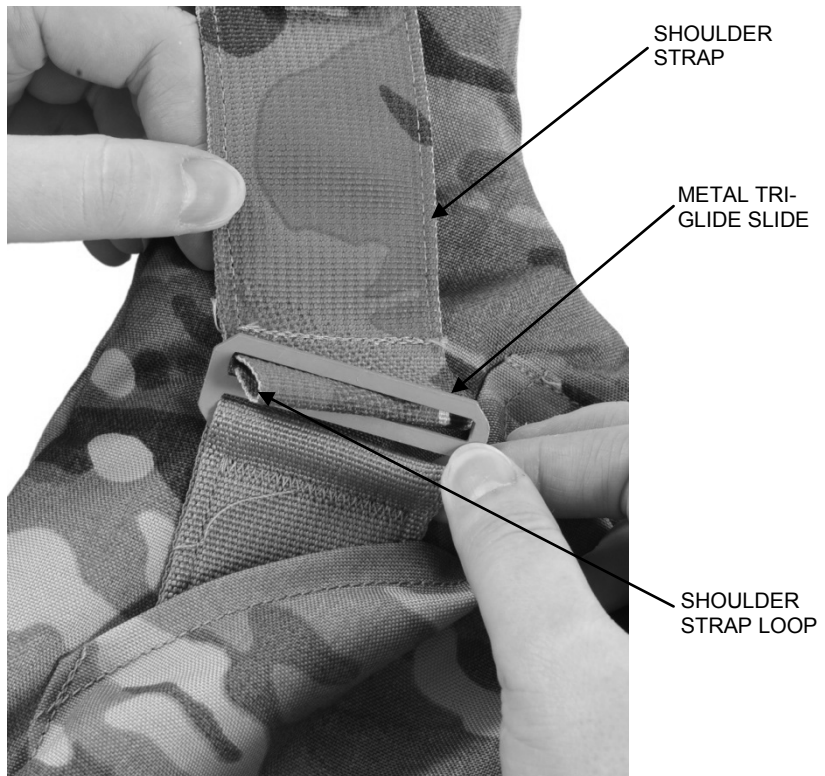

Figure 7. Inserting Shoulder Strap through Tri-Glide Slide on Front Carrier.

ASSEMBLY AND PREPARATION FOR USE — CONTINUED

- b. Thread the cable through the loop on the end of the shoulder strap from the center of the vest toward the outside (Figure 8).

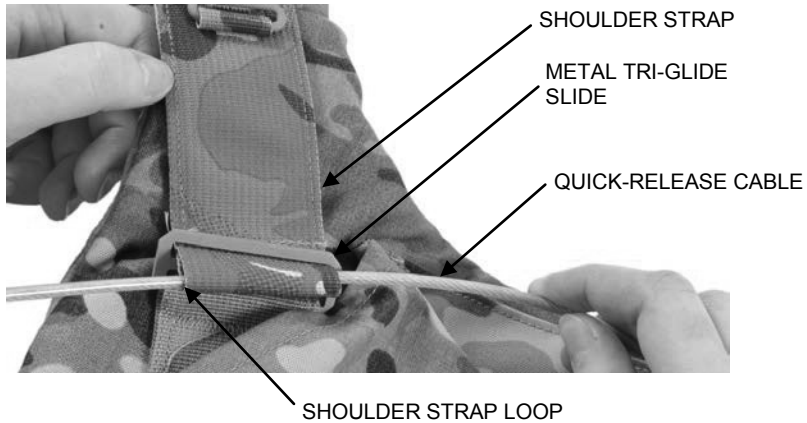

Figure 8. Threading the Cable through Shoulder Strap Loop (Interior View).

- c. Repeat steps a and b to attach the other shoulder strap.
6. Attach the female quick release buckles:
- a. Insert the nylon webbing portion of a female quick release buckle through the hole in the side of the front carrier, then through the top metal rectangular ring (Figure 9).

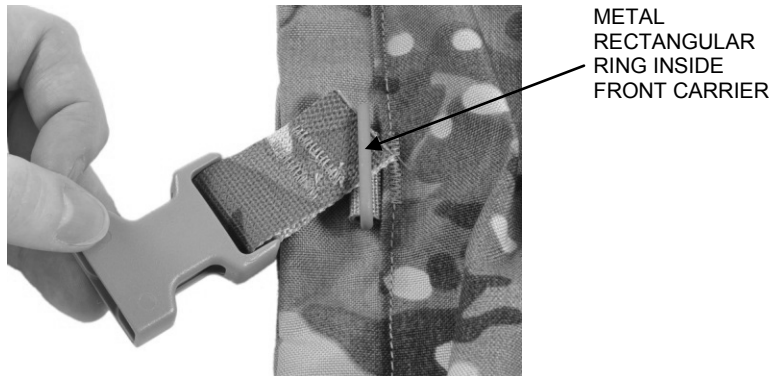

Figure 9. Inserting a Quick Release Buckle through Metal Ring (Interior View).

- b. Insert the nylon webbing portion of another quick release buckle through the bottom metal rectangular ring.

ASSEMBLY AND PREPARATION FOR USE — CONTINUED**WARNING**

Ensure the quick release cable is located to the inside side of the metal rectangular ring (closer to the center of the front carrier). Failure to do so could adversely affect the function of the quick-release, causing injury or death to personnel.

- c. Thread the release cable through the webbing of both quick release buckles, from the top of the vest toward the bottom (Figure 10).

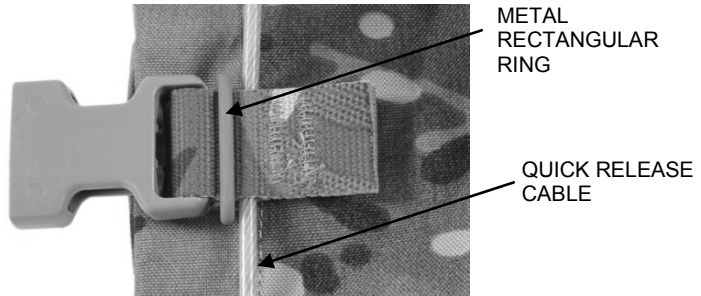

Figure 10. Threading Cable through Quick Release Buckles (Interior View).

- d. Repeat steps a through c to attach the other two quick release buckles and thread the quick release cable through them.
7. Stow the cable ends in the channels inside the ESAPI/XSAPI pocket (Figure 11).

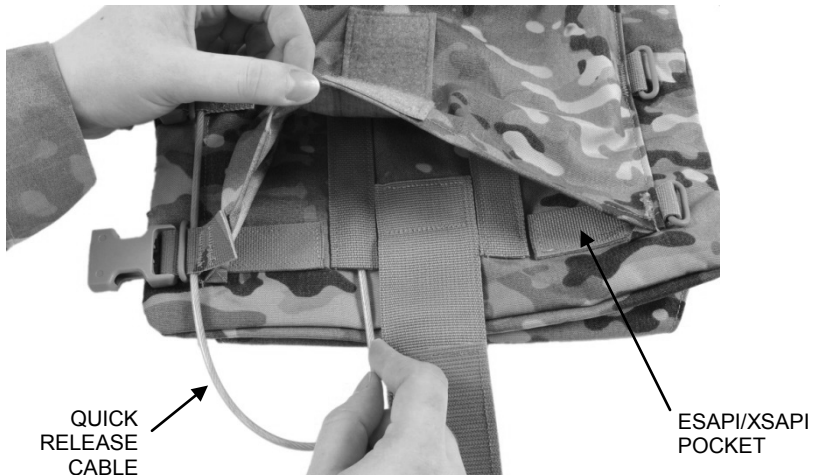

Figure 11. Stowing the End of the Cable.

8. Secure front carrier flap with the hook and loop tape on the underside of the carrier.

ASSEMBLY AND PREPARATION FOR USE — CONTINUED

Attach the Separation Strap Assemblies (as needed)

1. Thread the long end of the angled t-strap through the tri-glide slide on the separation strap assembly.

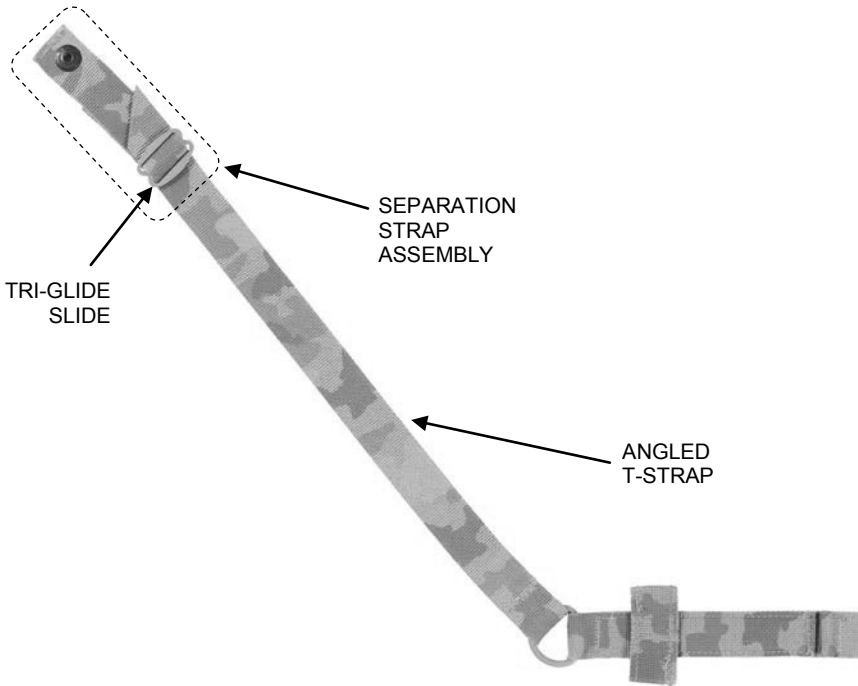

Figure 12. Separation Strap Assembly Attached to Angled T-Strap.

2. Thread the side plate carrier rear attachment straps through the tri-glide slides of the separation strap assemblies with the oval ring, and repeat for the second plate carrier (Figure 13).

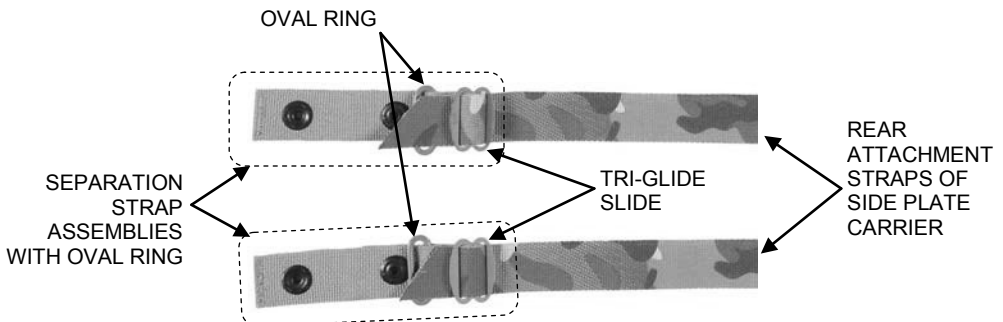

Figure 13. Separation Strap Assemblies Attached to SPC Straps.

ASSEMBLY AND PREPARATION FOR USE — CONTINUED

3. Double all straps back through the tri-glide slides to lock them.

Attach the Angled T-Straps to the Side Plate Carriers**NOTE**

The angled t-straps of the earlier side plate carriers are permanently attached to the side plate carriers. More recent plate carriers have detachable angled t-straps.

1. Place the side plate carrier on a clean surface, with the data label side down and buckles facing away from you (Figure 14).

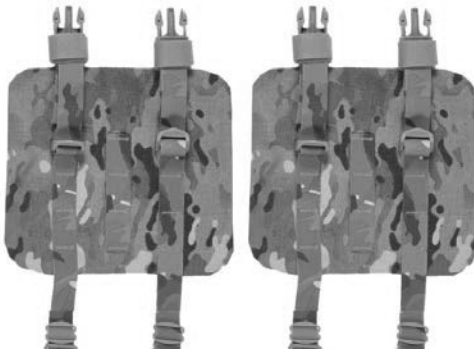

Figure 14. Side Plate Carriers Prepared for Angled T-Strap.

2. Feed the snap end of separation strap assembly attached to angled t-strap under the top row of webbing (Figure 15).

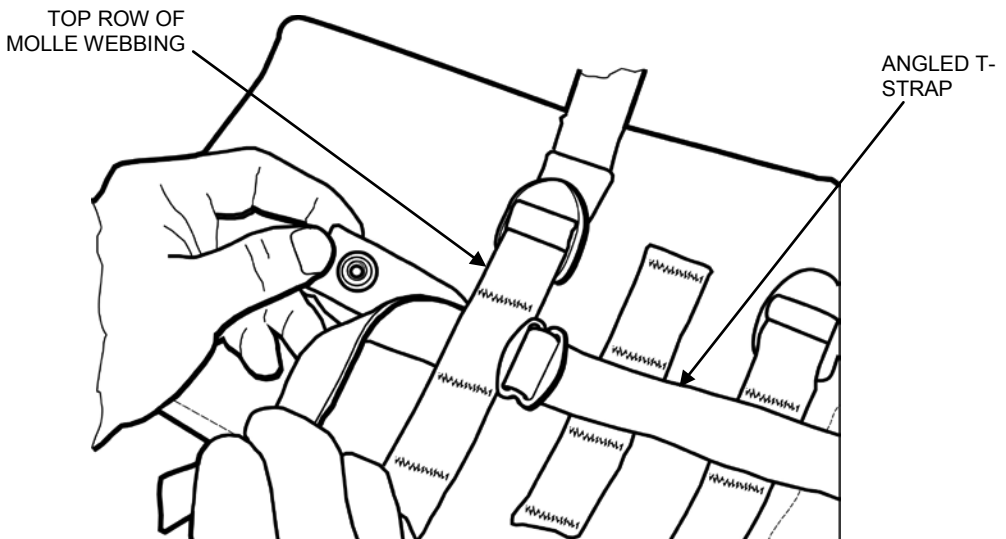

Figure 15. Snap End Under Webbing.

ASSEMBLY AND PREPARATION FOR USE — CONTINUED

3. Pull the angled t-strap under the webbing until D-ring has passed under the top row of the webbing (Figure 16).

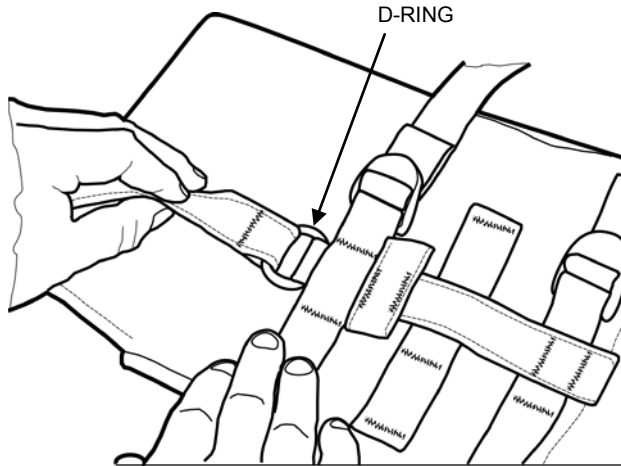

Figure 16. D-Ring Passed Under Webbing.

4. Slide tab end of angled t-strap under middle and bottom rows of webbing ensuring that tab is completely through the bottom row (Figure 17).

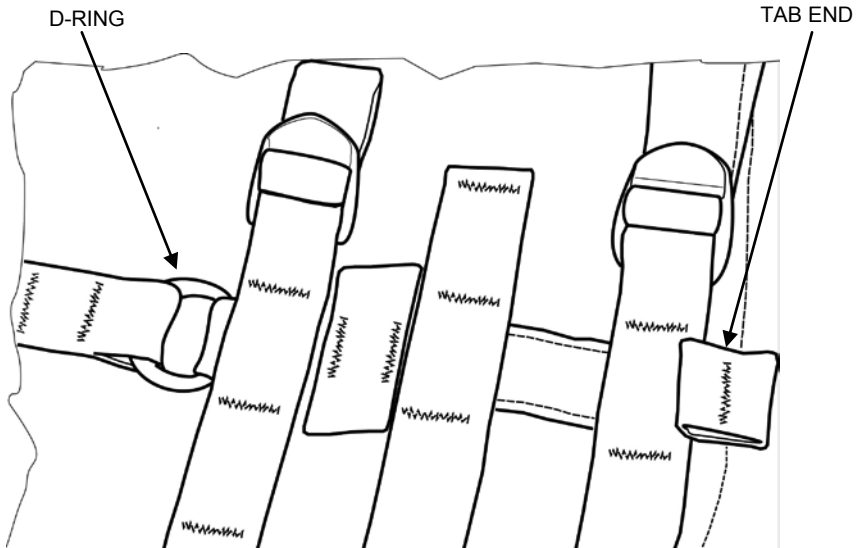

Figure 17. Properly Inserted Angled T-Strap.

ASSEMBLY AND PREPARATION FOR USE — CONTINUED

5. Repeat steps 1-4 for the strap on the other side plate carrier.



Figure 18. Side Plate Carrier with Angled T-Strap.

Attach the Side Plate Carriers to the Back Carrier**NOTE**

For the non-side-plate-carrier configuration, see “Attach the Attachment Straps to the Front and Back Carriers” in this work package.

1. Lay the back carrier down on a clean surface with the exterior surface facing up.
2. Lift the cover of the back carrier by separating the hook and loop fastener on the underside of the carrier to allow access to the SPC attachment points (Figure 19).



Figure 19. Opening the Back Carrier.

ASSEMBLY AND PREPARATION FOR USE — CONTINUED

3. Reach into the back carrier and push the D-ring to the outside (Figure 20).



Figure 20. D-Ring for Attaching SPC Strap.

4. Place the side plate carrier label-side down next to the back carrier.
5. Thread the separation strap assembly attached to the end of the angled t-strap through the D-ring, and snap it closed (Figure 21).



Figure 21. Attaching Angled T-Strap to D-Ring.

6. Double all straps back through the tri-glide slides to lock them.

ASSEMBLY AND PREPARATION FOR USE — CONTINUED

7. Tuck any extra webbing into the back carrier slot (Figure 22).



Figure 22. Tucking Extra Webbing into Back Carrier.

8. Insert the middle strap into the middle slot on the back carrier (Figure 23).



Figure 23. Inserting Middle SPC Strap.

ASSEMBLY AND PREPARATION FOR USE — CONTINUED

9. Take the end of the middle strap that has the snap on it, insert it through the middle metal loop on the back carrier (with the metal loop on the strap facing up) and snap it closed (Figure 24).



Figure 24. Attaching Middle SPC Strap to Back Carrier.

8. Adjust the length of the middle strap using the tri-glide slide if necessary.
9. Double the strap back through the tri-glide slide to lock them.
10. Take the lower SPC strap end that has the snap on it, insert it through the lower metal loop on the back carrier (with the metal loop on the strap facing up) and snap it closed (Figure 25).



Figure 25. Attaching Lower SPC Strap to Back Carrier.

ASSEMBLY AND PREPARATION FOR USE — CONTINUED

11. Adjust the length of the lower strap using the tri-glide slide if necessary.
12. Double the strap back through the tri-glide slides to lock them.
13. Repeat steps 3 through 12 to attach the other side plate carrier.

Attach the Attachment Straps to the Front and Back Carriers (Non-Side-Plate-Carrier Configuration Only)

1. Insert the end of an attachment strap that has the snap on it into the slot on the back carrier (Figure 26).



Figure 26. Inserting Attachment Strap into Back Carrier.

2. Insert the end of the strap through the upper metal loop on the inside of the back carrier (with the metal loop on the strap facing up) and snap it closed (Figure 27).



Figure 27. Attaching Attachment Strap to Back Carrier.

ASSEMBLY AND PREPARATION FOR USE — CONTINUED

3. Take another strap and insert the end that has the snap on it through the lower metal loop on the inside of the back carrier (with the metal loop facing up) and snap it closed (Figure 28).



Figure 28. Attaching Lower Attachment Strap to Back Carrier.

4. Repeat steps 1 through 3 to attach the other two attachment straps to the other side of the back carrier.
5. Adjust the length of the straps using the tri-glide slides if necessary.

Install Soft Ballistic Inserts

1. Place the front carrier on a clean surface with the exterior surface facing down.
2. Open the soft ballistic insert pocket by separating the hook and loop fastener (Figure 29).



Figure 29. Opening the Soft Ballistic Insert Pocket of Front Carrier.

ASSEMBLY AND PREPARATION FOR USE — CONTINUED

- Lift the outer cover of the front carrier by separating the hook and loop tape on the underside of the carrier and flipping the cover up (Figure 31).



Figure 31. Opening Outer Cover of Front Carrier.

- Pull the tab on the hook and loop fastener to expose the ESAPI/XSAPI pocket (Figure 32).



Figure 32. Opening ESAPI/XSAPI Pocket.

ASSEMBLY AND PREPARATION FOR USE — CONTINUED

4. Insert ESAPI/XSAPI into the pocket with data label facing the body (strike face side up) (Figure 33).



Figure 33. Inserting ESAPI/XSAPI.

5. Reattach the hook and loop fastener to close the ESAPI/XSAPI pocket.
6. Tighten the webbing enough to hold the hard armor in the pocket firmly in place with no slipping.
7. Close the top cover flap and seal the hook and loop fastener tape.
8. Repeat steps 1 through 7 to install the ESAPI/XSAPI in the back carrier.

ASSEMBLY AND PREPARATION FOR USE — CONTINUED**Install Soft Ballistic Inserts into Side Plate Carriers**

1. Place the side plate carrier on a clean surface with the exterior surface facing down.
2. Open the pocket for the soft ballistic by separating the hook and loop fastener on the exterior flap and then separating the hook and loop on the interior flap (Figure 34).



Figure 34. Opening Interior Compartment of Side Plate Carrier.

3. Fold the soft ballistic insert at the sides and slide it all the way into the carrier with the data label facing up (Figure 35).



Figure 35. Inserting Soft Ballistic in Side Plate Carrier.

ASSEMBLY AND PREPARATION FOR USE — CONTINUED

4. Reach into the carrier and smooth the insert to make sure it is lying flat and flush with the edges.
5. Tuck the interior flap into the compartment and seal the hook and loop fastener.
6. Close the exterior flap and seal the hook and loop fastener.
7. Repeat steps 1 through 9 to install the soft ballistic into the second side plate carrier.

Install Hard Armor ESBI/XSBI Plates

1. Place the side plate carrier on a clean surface with the exterior surface facing down.
2. Unfasten the hook and loop fastener on the exterior flap.
3. Slide the ESBI/XSBI into the compartment (under the compartment for the soft ballistic) with the data label facing up and the strike face side down (Figure 36).



Figure 36. Inserting ESBI/XSBI under Compartment for Soft Ballistic.

ASSEMBLY AND PREPARATION FOR USE — CONTINUED

4. Fold the flap of the compartment over the ESBI/XSBI and reattach the hook and loop fastener.
5. Repeat steps 1 through 4 to install the ESBI/XSBI in the other side plate carrier.

END OF TASK**DISASSEMBLY****Disassemble the Soldier Plate Carrier System**

1. Remove ESAPI/XSAPI plates from the front and back carriers, if installed.
 - a. Open the main compartment of the front carrier by separating the hook and loop fastener.
 - b. Open the ESAPI/XSAPI pocket by pulling the pull-tab.
 - c. Pull out the ESAPI/XSAPI plate from the ESAPI/XSAPI pocket (Figure 37).
 - d. Repeat steps a through c to remove the ESAPI/XSAPI plate from the back carrier.

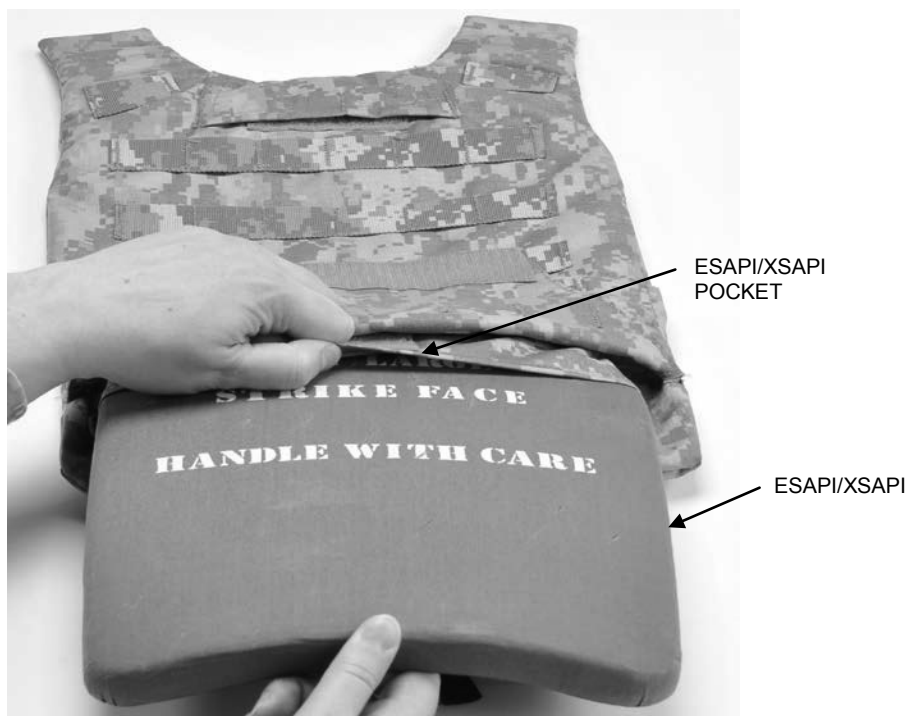

Figure 37. Removing ESAPI/XSAPI from Pocket.

DISASSEMBLY — CONTINUED

2. Remove ESBI/XSBI plates from side plate carriers, if installed.
 - a. Open the outside flap of the side plate carrier.
 - b. Pull out the ESBI/XSBI plate.
 - c. Repeat steps a and b to remove the ESBI/XSBI plate from the other side plate carrier.
3. Remove the soft ballistic inserts from front, back, and side carriers.
 - a. Open the soft ballistic insert compartment of the front carrier by separating the hook and loop fastener.
 - b. Remove the soft ballistic insert (Figure 38).



Figure 38. Removing Soft Ballistic Insert from Front Carrier.

- c. Repeat steps a and b to remove the soft ballistic inserts from the back carrier and both side plate carriers.

DISASSEMBLY — CONTINUED

4. Buckle either the side plate carrier straps or the attachment straps (for non-side-plate-carrier configuration) to the front carrier (Figure 39), then pull the quick release cable all the way out.



Figure 39. Side Plate Carriers Buckled to Front Carrier.

5. Detach the side plate carriers or the attachment straps from the back carrier by unsnapping the metal snaps on each strap (Figure 40).



Figure 40. Detaching Side Plate Carrier Snaps from Back Carrier.

6. Detach the angled strap from the side plate carriers, if detachable, by sliding the tab end of the angled t-strap out from under the webbing.

DISASSEMBLY — CONTINUED

7. Detach the shoulder straps from the back carrier at the tri-glide slides (Figure 41).



Figure 41. Detaching Shoulder Straps from Back Carrier.

END OF TASK

END OF WORK PACKAGE

**OPERATOR MAINTENANCE
SOLDIER PLATE CARRIER SYSTEM
CUMMERBUND CONFIGURATION
OPERATION UNDER USUAL CONDITIONS – ASSEMBLY AND DISASSEMBLY**

INITIAL SETUP

References:

WP 0002
WP 0005
WP 0010

ASSEMBLY AND PREPARATION FOR USE

Inventory

Proper sizing of the Soldier plate carrier system is critical to its ability to protect you from ballistic threats. This includes ensuring each component of your plate carrier is the correct size.

1. Confirm that you have the cummerbund configuration of the Soldier plate carrier system as shown in Figure 1.





Figure 1. Soldier Plate Carrier System (Cummerbund Configuration).

2. Inventory system using Table 1.
 - a. The first column lists the name of the component to be inventoried.
 - b. The second column indicates the quantity of that item required to make a complete plate carrier system.

For additional information, see WP 0002.



ASSEMBLY AND PREPARATION FOR USE — CONTINUED

Table 1. Plate Carrier Inventory (Cummerbund Configuration).

COMPONENT	QTY	FIGURE
Front Carrier	1	
Back Carrier	1	
Shoulder Strap (on back carrier)	2	



ASSEMBLY AND PREPARATION FOR USE — CONTINUED

Table 1. Plate Carrier Inventory (Cummerbund Configuration) – Continued.

COMPONENT	QTY	FIGURE
Male Quick Release Buckle (on front carrier)	4	
Cable Release Assembly (on front carrier)	1	
Left Cummerbund Assembly (with side plate pocket, angled t-strap, separation strap assemblies, and two separation strap assemblies with oval rings)	1	

ASSEMBLY AND PREPARATION FOR USE — CONTINUED

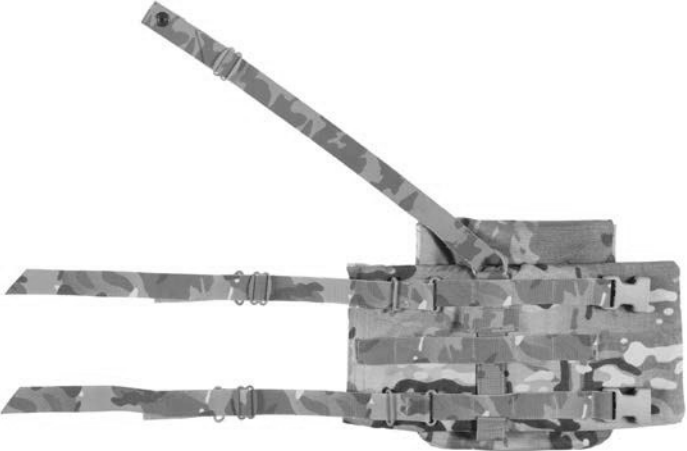
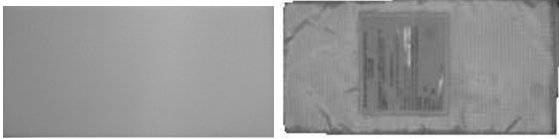
Table 1. Plate Carrier Inventory (Cummerbund Configuration) – Continued.

COMPONENT	QTY	FIGURE
Right Cummerbund Assembly (with side plate pocket, angled t-strap, separation strap assemblies, and two separation strap assemblies with oval rings)	1	
Plastic Stiffener and Soft Ballistic Insert (for cummerbund)	1 ea	
Vest Soft Ballistic Insert	2	
Side Plate Pocket Soft Ballistic Insert	2	

*Additional optional components may be included as determined by mission requirements.

ASSEMBLY AND PREPARATION FOR USE — CONTINUED

3. Check the interior side of each component for a data label.
4. Ensure each component is the correct size for your system as indicated in Table 2.
 - a. On the first row, find the vest size of your plate carrier.
 - b. As you inventory each component, find that component in the left-most column of Table 2. The correct size for each component is listed at the intersection of the row for the individual component and the column for the size of your vest.
 - c. If a component is not the correct size, or if it does not have a data label, turn it in for a properly-sized component.

Table 2. Plate Carrier Component (Cummerbund Configuration) Sizing Chart.

Vest Size	XS	S	M	L	XL	2XL
Front Carrier & Soft Ballistic Insert	XS	S	M	L	XL	XL
Back Carrier & Soft Ballistic Insert	XS	S	M	L	XL	2XL
Shoulder Straps	XS	S	M	L	XL	2XL
Cable Release Assembly	U	U	U	U	U	U
Cummerbund	XS-S	XS-S	M-L	M-L	XL-2XL	XL-2XL
Angled T-Straps	U	U	U	U	U	U
Side Plate Pocket	U	U	U	U	U	U
Side Plate Pocket Soft Ballistic Inserts	U	U	U	U	U	U
ESAPI/XSAPI Plates	XS	S	M	L	XL	XL
ESBI/XSBI Plates	U	U	U	U	U	U

5. Inspect each component using Table 1, WP 0010, Preventive Maintenance Checks and Services.

END OF TASK

ASSEMBLY AND PREPARATION FOR USE — CONTINUED**Assemble Base Vest Assembly****WARNING**

Ensure there are no kinks in the quick-release cable. Failure to do so could adversely affect the function of the quick-release, causing injury or death to personnel.

CAUTION

Ensure the sizes of the front and back carrier match by comparing data label information. Ensure the sizes of the side plate carriers match the sizes of the front and back carriers by comparing data label information. Failure to do so could affect fit.

NOTE

The term “inside surface,” “inside fabric” or “inside” means the area of any SPCS component that is between the exterior and interior surfaces (Figure 2). The inside or inside surface of a SPCS component is the portion that touches the soft ballistic inserts.

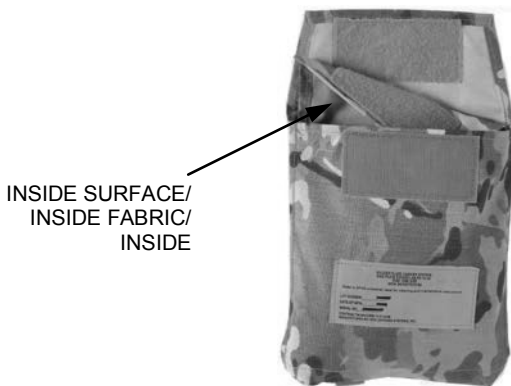

Figure 2. Inside Pocket of Side Plate Pocket.

ASSEMBLY AND PREPARATION FOR USE — CONTINUED**NOTE**

The term “interior fabric” or “interior surface” means the side of any component of the SPCS that faces the Soldier when worn. The term exterior fabric or exterior surface means the side of any component of the SPCS that faces away from the Soldier (Figure 3).



Figure 3. Exterior and Interior of SPCS (Cummerbund Configuration).

ASSEMBLY AND PREPARATION FOR USE — CONTINUED

1. Attach the shoulder straps to the back carrier:
 - a. Thread the 2-inch nylon webbing of the shoulder strap through the tri-glide slide on the back carrier (Figure 4).



Figure 4. Attaching Shoulder Strap to Back Carrier.

- b. Double the strap back through the tri-glide slide before stowing the excess strap and buckle inside the back carrier (Figure 5).



Figure 5. Stowing the Shoulder Strap and Tri-Glide Slide.

ASSEMBLY AND PREPARATION FOR USE — CONTINUED

- c. Repeat steps a and b for the second strap.
2. Open the front panel of the front carrier to allow access to the cable release channels inside the carrier (Figure 6).



Figure 6. Access to Cable Release Channels.

3. Insert the cable ends through the holes on either side of the cable release pocket (Figure 7).



Figure 7. Inserting Cable Ends through Holes in Cable Release Pocket.

ASSEMBLY AND PREPARATION FOR USE — CONTINUED

4. Pull the cables through so the pull-tab is centered on the loop fastener (Figure 8).

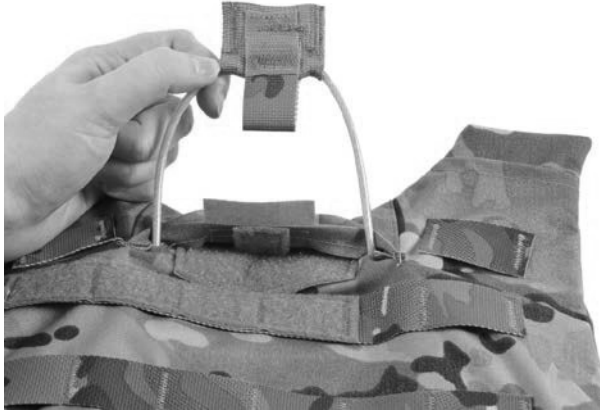

Figure 8. Pulling Both Cables through Holes.

5. Attach the shoulder straps to the front carrier:

NOTE

For Figures 9 through 11, the front carrier is shown inside-out to better illustrate the procedures. During actual assembly, most of the attachment points on the front carrier are not visible. The procedures must be performed by touch.

- a. Insert the looped end of the 2-inch nylon webbing of the shoulder strap through the slot on the metal slide inside the front carrier (Figure 9).

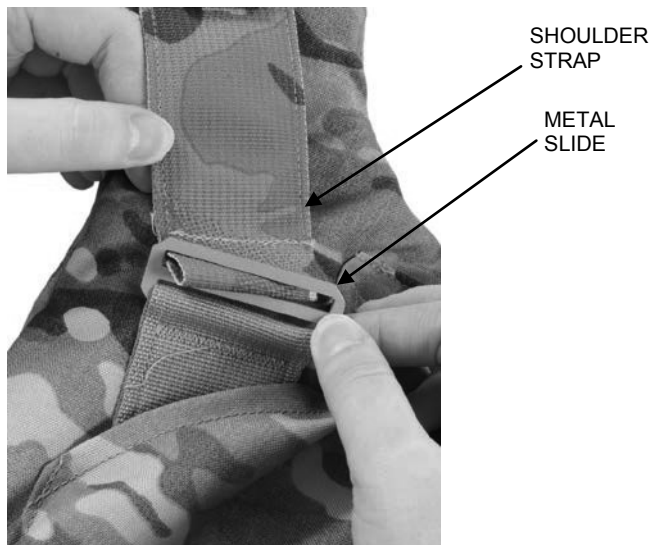

Figure 9. Inserting Shoulder Strap through Tri-Glide Slide on Front Carrier.

ASSEMBLY AND PREPARATION FOR USE — CONTINUED

- b. Thread the release cable through the loop on the end of the shoulder strap from the center of the vest toward the outside (Figure 10).

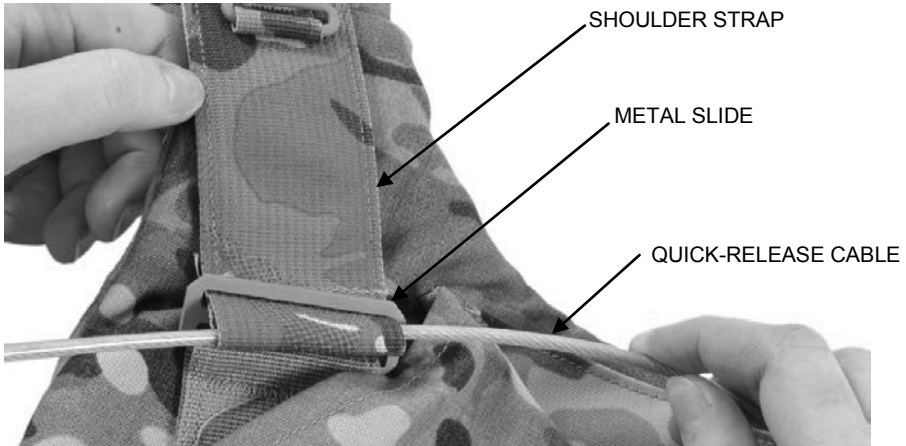

Figure 10. Threading the Cable through Shoulder Strap Loop (interior view).

- c. Repeat steps a and b to attach the other shoulder strap.
6. Remove female buckles from front carrier if necessary.
- Remove cable ends from the cable channels.
 - Unthread cable from two female buckles on each side of the front carrier.
7. Attach the male quick release buckles:
- Insert the nylon webbing portion of a male quick release buckle through the hole in the side of the front carrier, then through the top metal rectangular ring (Figure 11).

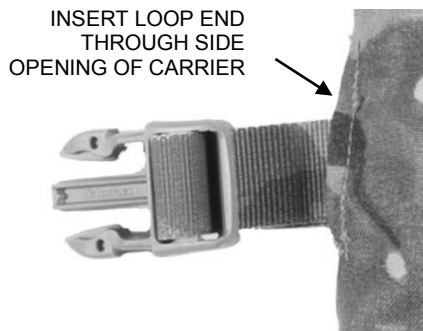

Figure 11. Inserting a Male Quick Release Buckle through Metal Ring (Interior View).

- Insert the nylon webbing portion of another male buckle through the bottom metal rectangular ring.

ASSEMBLY AND PREPARATION FOR USE — CONTINUED**WARNING**

Ensure the quick release cable is located to the inside side of the metal rectangular ring (closer to the center of the front carrier). Failure to do so could adversely affect the function of the quick-release, causing injury or death to personnel.

- c. Thread the release cable through the webbing of both quick release buckles, from the top of the vest toward the bottom.
 - d. Repeat steps a through c to attach the other two male buckles, and thread the quick release cable through them.
8. Stow the cable ends in the channels inside the ESAPI/XSAPI pocket (Figure 12).

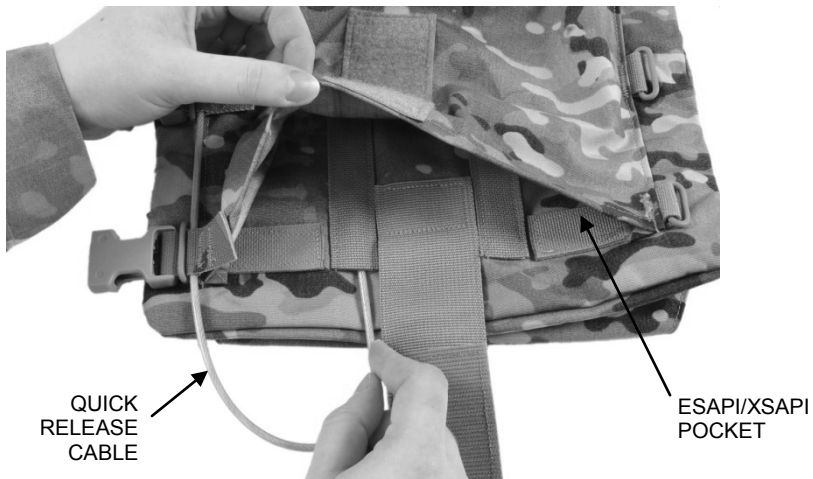

Figure 12. Stowing the End of the Cable.

9. Secure front carrier flap with the hook and loop tape on the underside of the carrier.

Attach the Separation Strap Assemblies (as needed)

1. Thread the long end of the angled t-strap through the tri-glide slide on the separation strap assembly.

ASSEMBLY AND PREPARATION FOR USE — CONTINUED

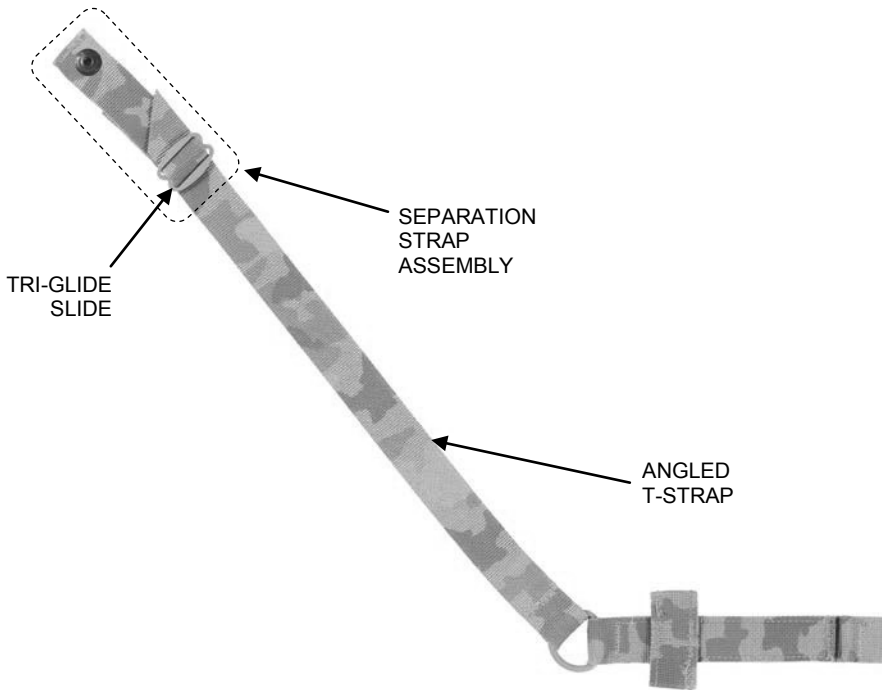

Figure 13. Separation Strap Assembly Attached to Angled T-Strap.

2. Thread the cummerbund attachment straps through the tri-glide slides of the separation strap assemblies with the oval ring, and repeat for the second cummerbund (Figure 14).

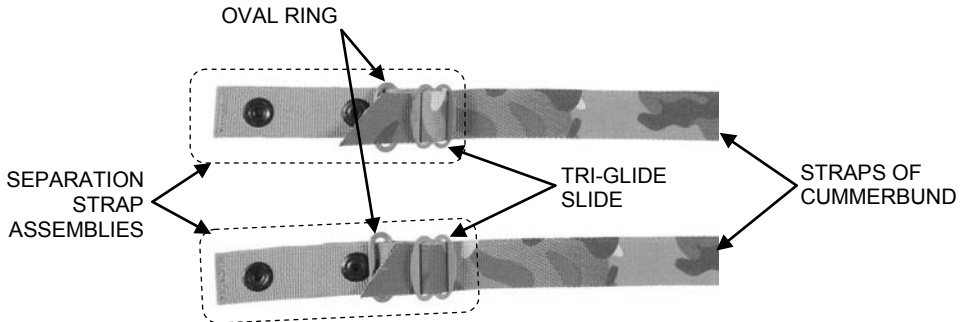

Figure 14. Separation Strap Assemblies Attached to Cummerbund Attachment Straps.

3. Double all straps back through the tri-glide slides to lock them.

ASSEMBLY AND PREPARATION FOR USE — CONTINUED**Attach the Angled T-Straps to the Cummerbund****NOTE**

If you are using the side plate carrier configuration, see WP 0005.

1. Position one section of the cummerbund on the work surface with the exterior facing up.
2. Feed the snap end of separation strap assembly attached to angled t-strap under the top row of webbing (Figure 15).

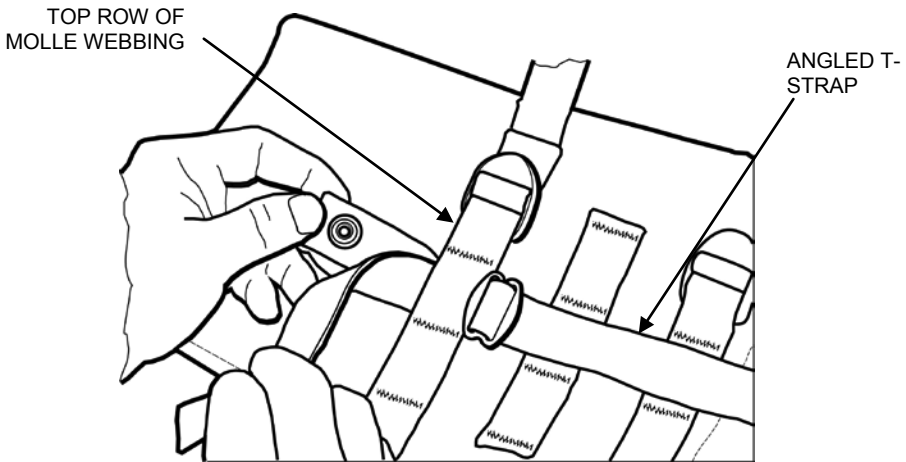

Figure 15. Snap End Under Webbing.

3. Pull the angled t-strap under the webbing until D-ring has passed under the top row of the webbing (Figure 16).

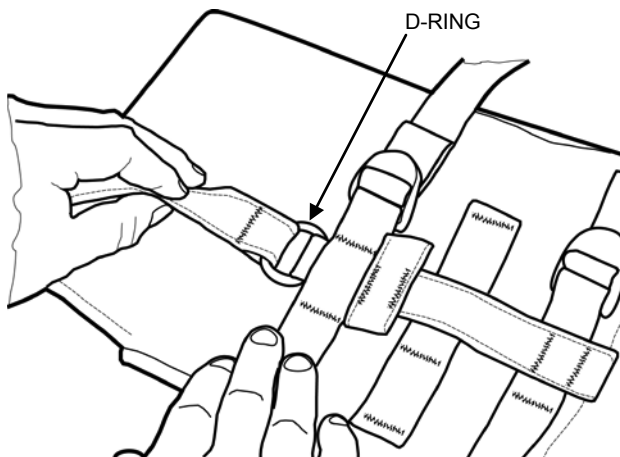

Figure 16. D-Ring Passed Under Webbing.

ASSEMBLY AND PREPARATION FOR USE — CONTINUED

- Slide tab end of angled t-strap under middle and bottom rows of webbing ensuring that tab is completely through the bottom row (Figure 17).

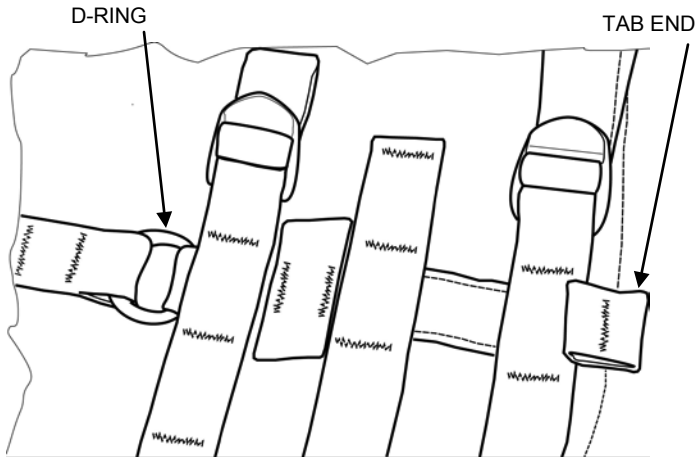

Figure 17. Properly Inserted Angled T-Strap.

- Repeat steps 1-4 for the strap on the other section of the cummerbund.

Attach the Side Plate Pockets to the Cummerbund

- Position one section of the cummerbund with the data label facing up and to right.
- Position the long straps of the side plate pocket close to the top of the cummerbund (Figure 18). The pocket's data label should be resting on the work surface.

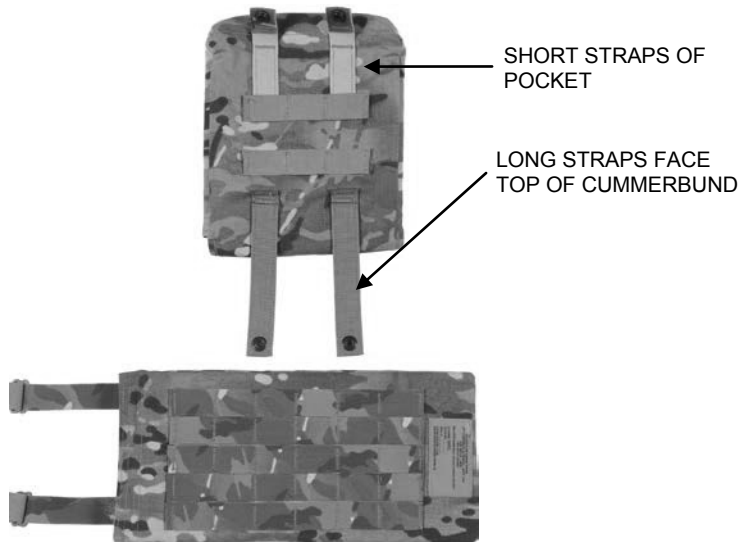

Figure 18. Side Plate Pocket and Cummerbund.

ASSEMBLY AND PREPARATION FOR USE — CONTINUED

3. Working from top to bottom, insert the pocket straps under the top row of webbing, then over the next row of webbing (Figure 19).

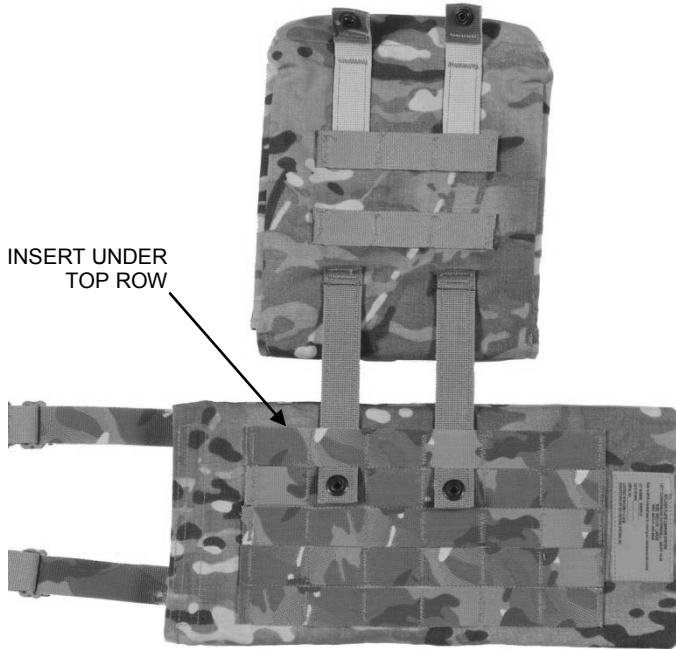

Figure 19. Inserting Straps of Side Plate Pocket through Webbing.

4. Continue threading the straps under the middle row of webbing, over the next row of webbing, and under the bottom row of webbing (Figure 20).

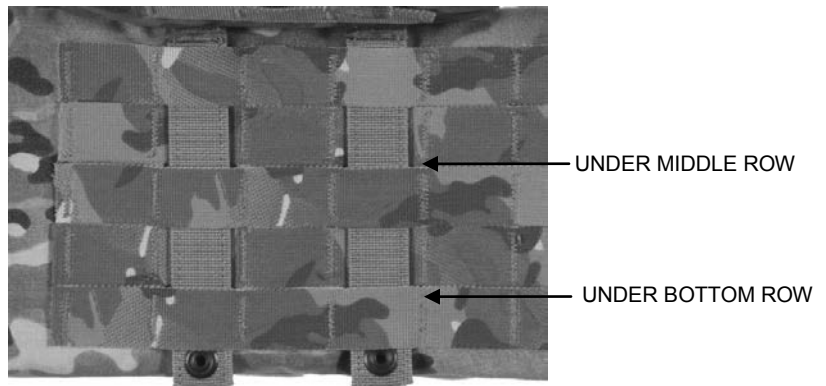

Figure 20. Pocket Straps Fully Inserted in Cummerbund.

ASSEMBLY AND PREPARATION FOR USE — CONTINUED

5. Fold the top of the pocket in toward the cummerbund and fasten the snaps of the short pocket straps to the long pocket straps. The data labels for the pocket and the cummerbund will be facing you (Figure 21).

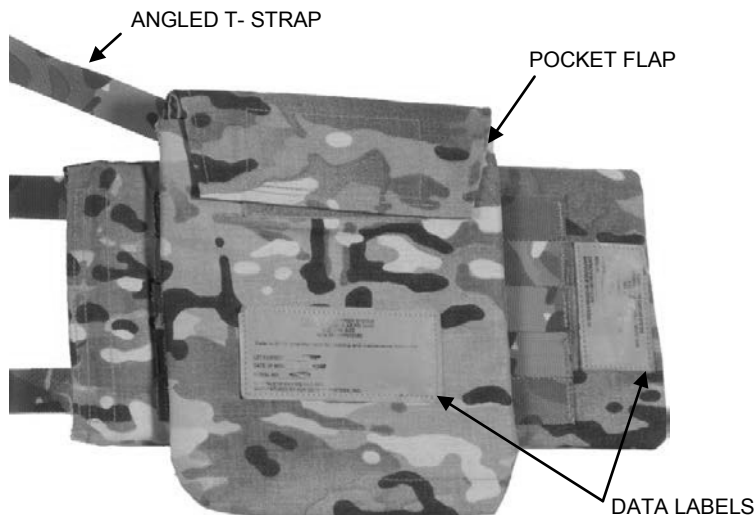

Figure 21. Data Labels Facing the Same Direction.

6. Position the second section of the cummerbund with the data label facing up and to the left. (The top of the angled t-strap will be at the top of the cummerbund and facing the working surface)
7. Repeat steps 2 through 6 to attach the other side plate pocket.

ASSEMBLY AND PREPARATION FOR USE — CONTINUED**Attach the Cummerbund to the Back Carrier**

1. Lay the back carrier down on a clean surface with the exterior surface facing up.
2. Position one section of the cummerbund beside the back carrier as shown in Figure 22.

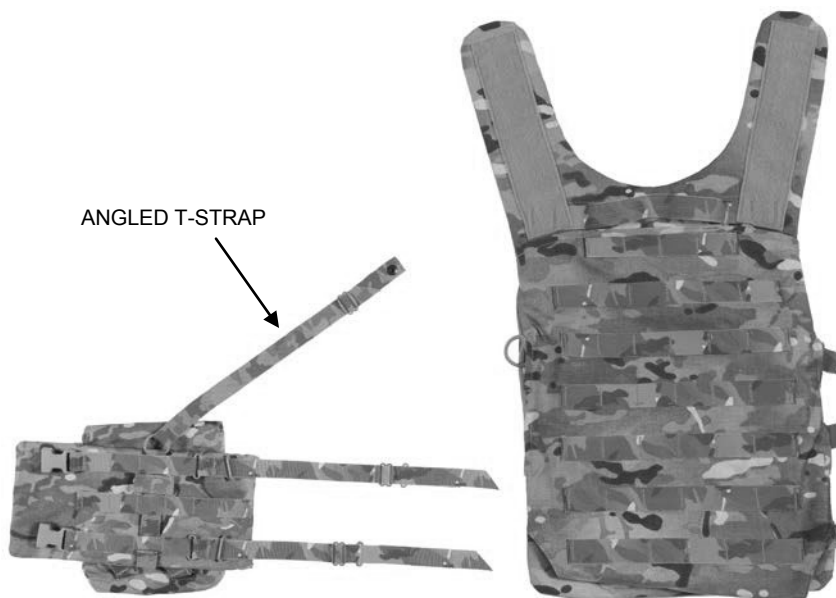

Figure 22. Positioning Cummerbund Assembly for Attachment.

3. Lift the cover of the back carrier by separating the hook and loop fastener on the underside of the carrier to allow access to the SPC attachment points (Figure 23).



Figure 23. Opening the Back Carrier

ASSEMBLY AND PREPARATION FOR USE — CONTINUED

4. Reach into the back carrier and push the D ring to the outside (Figure 24).

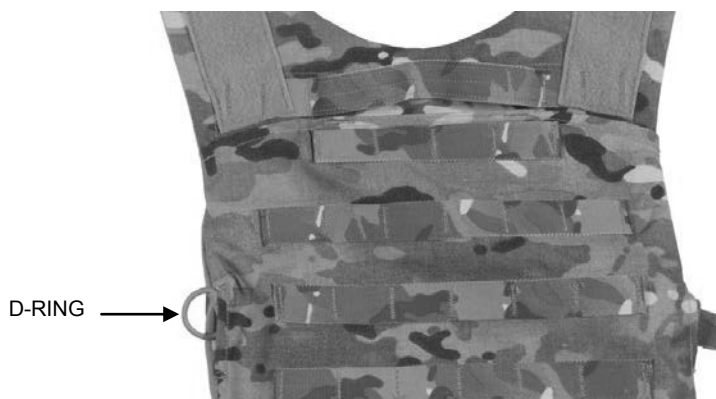

Figure 24. Pull D-Ring through to Outside of Back Carrier.

5. Insert the snap end of the angled t-strap through the D ring and snap the fastener closed. Tuck the D-Ring back into the back carrier (Figure 25).



Figure 25. Insert Snap End of Angled T-Strap through D-Ring.

ASSEMBLY AND PREPARATION FOR USE — CONTINUED

6. Insert the TOP strap of the cummerbund into the MIDDLE slot of the back carrier, as shown in Figure 26.

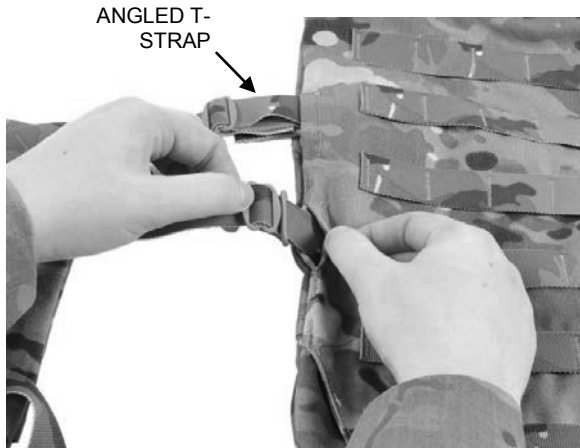

Figure 26. Top Strap of Cummerbund Inserted in Back Carrier.

7. Thread the snap end through the middle metal loop on the back carrier (with the metal loop on the strap facing up) and snap it closed (Figure 27).



Figure 27. Insert Snap End through Inside Metal Ring.

8. Adjust the length of the strap using the tri-glide slide if necessary.

ASSEMBLY AND PREPARATION FOR USE — CONTINUED

9. Insert the lower strap of the cummerbund into the lower slot of the back carrier, as shown in Figure 28.



Figure 28. Left Cummerbund Assembly Attached to Back Carrier.

10. Thread the snap end through the lower metal loop on the back carrier (with the metal loop on the strap facing up), and snap it closed.
11. Adjust the length of the strap using the tri-glide slide if necessary.
12. Repeat steps 1 through 10 to attach the other side of the cummerbund to the back carrier.

ASSEMBLY AND PREPARATION FOR USE — CONTINUED

13. Close the hook and loop fastener on the back carrier.



Figure 29. Back Carrier with Cummerbund Assembly Installed.

Install Soft Ballistic Ins in Front and Back Carriers**WARNING**

For maximum protection soft ballistic inserts are always placed against the body, behind hard armor protection. Failure to do so could adversely affect the protection provided, causing injury or death to the service member.

1. Place the front carrier on a clean surface with the exterior surface facing down.
2. Open the soft ballistic insert pocket by separating the hook and loop fastener.

ASSEMBLY AND PREPARATION FOR USE — CONTINUED

3. Fold the soft ballistic insert at the sides and slide it all the way into the carrier with the data label facing up (Figure 30).



Figure 30. Inserting a Soft Ballistic into Front Carrier.

4. Reach into the carrier and smooth the insert to make sure it is lying flat and flush with the edges.
5. Tuck the bottom of the insert into the compartment and seal the hook and loop fastener closed.
6. Repeat steps 1 through 5 to install soft ballistic inserts into the back carrier.

Install Plastic Stiffener and Soft Ballistics in the Cummerbund

3. Position one side of the cummerbund outer shell with the label facing up.
4. Open the hook and loop fastener on the end of the cummerbund outer shell.
5. Slide the soft ballistic insert into the outer shell with the data label facing up.

ASSEMBLY AND PREPARATION FOR USE — CONTINUED

- Slide the plastic stiffener into the outer shell on top of the soft ballistic (Figure 31). The plastic insert is on the inside closest to the body, and the soft ballistic insert is closest to the exterior.

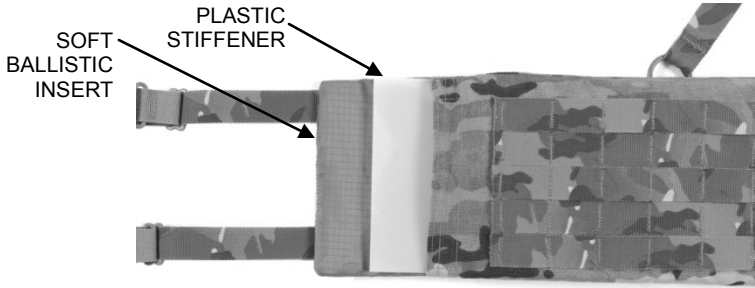

Figure 31. Plastic Stiffener and Soft Ballistic Inserts in Cummerbund.

- Repeat steps 1-4 for the other side of the cummerbund.

Install Soft Ballistics in Side Plate Pockets**NOTE**

When inserting soft ballistics and plates, ensure that all labels face in the same direction as the labels on the carrier.

- Place the side plate pocket on a clean surface with the exterior side facing down and the label side facing up with the pocket flap nearest you.
- Open the pocket by separating the hook and loop fastener. Notice that there is also an inner pocket
- Open the inner pocket by separating the hook and loop fastener.
- Slide the soft ballistic insert with the label facing up into the inner pocket (Figure 32).

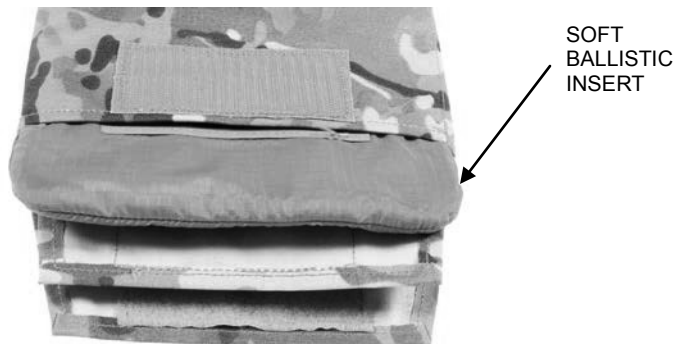

Figure 32. Soft Ballistic Insert in Side Plate Pocket.

ASSEMBLY AND PREPARATION FOR USE — CONTINUED

5. Tuck the inner flap into the inner pocket, and seal the hook and loop (Figure 33).



Figure 33. Close Inner Pocket.

6. Repeat steps 1 through 5 for the second side plate pocket.

Install Hard Armor ESAPI/XSAPI Plates in Front and Back Carriers**NOTE**

When inserting soft ballistics and hard armor protective inserts, make sure that all labels face in the same direction as the labels on the carrier.

1. Lay the front carrier on a flat surface with the exterior surface facing up.
2. Lift the outer cover of the front carrier by separating the hook and loop tape on the underside of the carrier and flipping the cover up (Figure 34).

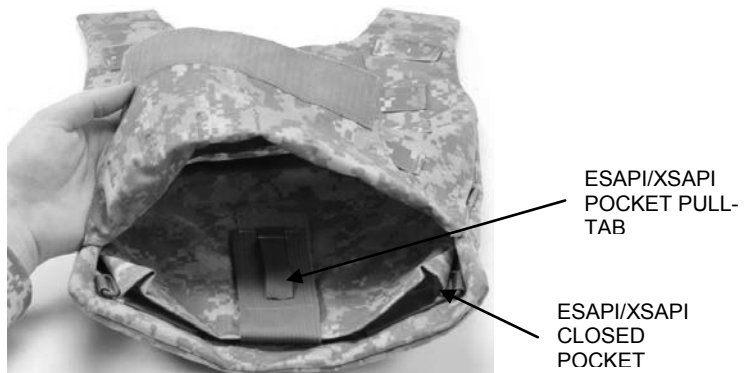

Figure 34. Opening Outer Cover of Front Carrier.

ASSEMBLY AND PREPARATION FOR USE — CONTINUED

3. Pull the tab on the hook and loop fastener to expose the ESAPI/XSAPI pocket (Figure 35).



Figure 35. Opening ESAPI/XSAPI Pocket.

4. Insert ESAPI/XSAPI into the pocket with data label facing the body (strike face up), as shown in Figure 36.



Figure 36. Inserting ESAPI/XSAPI.

ASSEMBLY AND PREPARATION FOR USE — CONTINUED

5. Close the front carrier cover by reattaching the hook and loop fastener.
6. Tighten the webbing to hold the hard armor in the compartment firmly with no slipping and attach the hook and loop fastener.
7. Repeat steps 1 through 6 to install the ESAPI/XSAPI into the back carrier.

Install Hard Armor ESBI/XSBI Plates

1. Place the side plate pocket on a clean surface with the exterior surface facing down.
2. Unfasten the hook and loop fastener on the exterior flap.
3. Slide the ESBI/XSBI into the compartment (under the compartment for the soft ballistic insert) with the data label facing up and the strike face side down (Figure 37).



Figure 37. Inserting ESBI/XSBI under Soft Ballistic Compartment.

ASSEMBLY AND PREPARATION FOR USE — CONTINUED

4. Fold the flap of the compartment over the ESBI/XSBI and reattach the hook and loop fastener.
5. Repeat steps 1 through 4 to install the ESBI/XSBI in the other side plate pocket.

END OF TASK**DISASSEMBLY****Disassemble the Soldier Plate Carrier System**

1. Remove ESAPI/XSAPI plates from the front and back carriers, if installed.
 - a. Open the main compartment of the front carrier by separating the hook and loop fastener.
 - b. Open the ESAPI/XSAPI pocket by pulling the pull-tab.
 - c. Pull out the ESAPI/XSAPI plate from the ESAPI/XSAPI pocket (Figure 38).
 - d. Repeat steps a through c to remove the ESAPI/XSAPI plate from the back carrier.



Figure 38. Removing ESAPI/XSAPI from Pocket.

DISASSEMBLY — CONTINUED

2. Remove ESBI/XSBI plates from side plate pockets, if installed.
 - a. Open the outside flap of the side plate pocket.
 - b. Pull out the ESBI/XSBI plate.
 - c. Repeat steps a and b to remove the ESBI/XSBI plate from the other side plate pocket.
3. Remove the soft ballistic inserts from front, back, cummerbund, and side plate pockets.
 - a. Open the soft ballistic insert pocket of the front carrier by separating the hook and loop fastener.
 - b. Remove the soft ballistic insert.
 - c. Repeat steps a and b to remove the soft ballistic inserts from the back carrier, cummerbund, and side plate pockets.
4. Remove the plastic stiffener from the cummerbund.
5. Buckle the cummerbund to the front carrier, then pull the quick release cable all the way out.
6. Detach the cummerbund from the back carrier using the three metal snaps on each strap (Figure 39).



Figure 39. Detaching Cummerbund from Back Carrier.

7. Detach the angled t-strap from the cummerbund, by sliding the tab end of the angled t-strap out from under the webbing.

DISASSEMBLY — CONTINUED

8. Detach the shoulder straps from the back carrier at the tri-glide slides (Figure 40).



Figure 40. Detaching Shoulder Straps from Back Carrier.

END OF TASK

END OF WORK PACKAGE

OPERATOR MAINTENANCE
SOLDIER PLATE CARRIER SYSTEM
OPERATION UNDER USUAL CONDITIONS – DON, DOFF, ADJUST

INITIAL SETUP

References:

WP 0010

DON

Prior to donning the plate carrier, attach all the components necessary to meet mission requirements. Insert hard armor plates if used.

1. Disconnect the side plate carriers (side plate carrier configuration), cummerbund (cummerbund configuration), or the attachment straps (non-side-plate-carrier configuration) from the front carrier at the plastic quick release buckles, if connected.
2. Place the vest over your head. (Figure 1).



Figure 1. Over-the-Head Donning.

NOTE

Be sure all straps lie flat and are not twisted before straps are buckled.

DON — CONTINUED

3. Buckle the side plate carriers, cummerbund, or attachment straps to the front carrier using the two plastic buckles on each side (Figure 2).

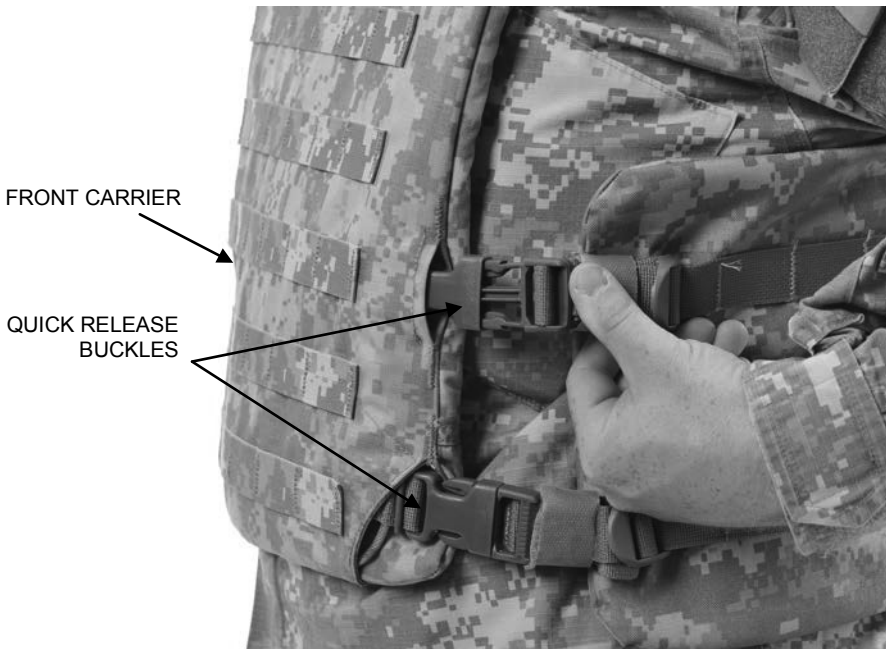

Figure 2. Buckling the Quick Release Buckles.

4. Tighten the straps as necessary.
5. Double-back all webbing through the tri rail, and put the excess back inside the vest.

END OF TASK

DOFF

There are two methods to doff the plate carrier. The primary method is the over-the-head method. The second is the emergency release method.

WARNING

The emergency release system should be used during emergencies or instructional purposes only. Using this method to routinely doff the vest could result in damage to the hard armor plates. Damage to the hard armor plates could result in degraded ballistic protection, which may cause injury or death to the wearer.

Doffing – Over-the-Head Method

NOTE

Doffing the vest from over the head is the primary release method. Only use the cable-release in emergency situations or for instructional purposes.

1. Unbuckle the four plastic buckles on the front carrier (Figure 3).



Figure 3. Detach the Four Buckles.

2. Lift the vest over the head.

DOFF – CONTINUED**Doffing – Cable Release Method****WARNING**

When using the cable release function for instructional purposes, do not allow the vest to fall to a solid floor, such as concrete or tile. The impact may damage the hard armor plates and could compromise the effectiveness of the plates. Damage to the hard armor plates could result in degraded ballistic protection, which may cause injury or death to the wearer.

NOTE

Any time the emergency release system is used, perform the PMCS in accordance with WP 0010.

Grasp the cable release tab at the center top of the front carrier and pull the cable all the way out of the vest (Figure 4). The vest will separate at the shoulders and sides. It may be necessary to detach the hook and loop fastener at the shoulders for the vest to completely separate.

QUICK-RELEASE
PULL TAB



Figure 4. Pulling the Quick Release Tab.

END OF TASK

ADJUST**NOTE**

If worn, the side plate carriers should be centered on the sides of the body, evenly between the front and back carriers.

The side plate carrier straps or the attachment straps should lie flat, with no bunching or slack.

When the wearer is seated, the vest should not place pressure on the legs or rise up into the wearer's throat (Figure 5).



Figure 5. Checking Fit of Plate Carrier.

1. Don vest and adjust as follows.

ADJUST – CONTINUED

2. Adjust the shoulder strap lengths (Figure 6): have an assistant lift the flap on the back carrier, reach under it to the shoulder attachment tri-glide buckles, and lengthen or shorten the straps as required.

SHOULDER STRAPS
ARE ADJUSTED
UNDERNEATH THE
BACK CARRIER
COVER AT THESE
POINTS



Figure 6. Shoulder Strap Adjustment Points.

ADJUST – CONTINUED

3. Adjust the side plate carrier, cummerbund, or attachment straps (Figure 7).
 - a. Have an assistant lift the flap on the back carrier and adjust the length of the side plate carrier straps or attachment straps using the tri-glide buckles. If worn, make sure the side plate carriers are centered on the sides of the body, evenly between the front and back carriers.
 - b. Tighten the front straps using the quick release buckles, while the assistant tightens the back straps, until the vest fits firmly and comfortably on the body. Ensure all straps are adjusted evenly, and that they lie flat, with no bunching or slack.
 - c. Secure excess webbing in webbing keepers.

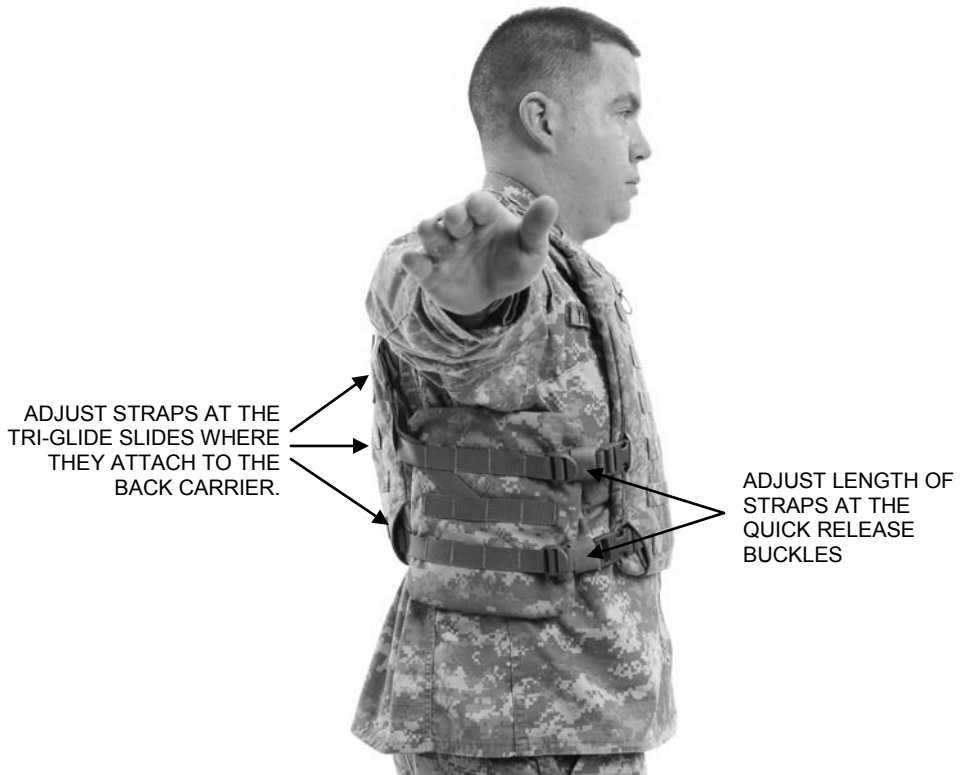

Figure 7. Side Carrier Adjustment Points.

4. Have the assistant close the back carrier flap and tuck the bottom up underneath the carrier to secure it with the hook and loop fastener.

END OF TASK

END OF WORK PACKAGE

**OPERATOR MAINTENANCE
SOLDIER PLATE CARRIER SYSTEM
OPERATION UNDER UNUSUAL CONDITIONS**

INITIAL SETUP**References:**FM 3.11.3

SOLDIER PLATE CARRIER SYSTEM

The Soldier Plate Carrier System is constructed to function in various temperature ranges and displays resistance to potentially caustic elements such as salt water.

Hard Armor Ballistic Inserts

The hard armor ballistic inserts are designed to be structurally and ballistically functional from -60 to 160 degrees Fahrenheit. The inserts are also designed for resistance to fluids such as diesel, gasoline and salt water. The inserts can be immersed in these fluids up to two hours before functionality is affected.

Ballistic Inserts

The soft armor is designed to meet 97.6% of the minimum performance of a dry sample when hot or cold, and 92.7% of the minimum performance of a dry sample when wet or diesel or gas soaked. Extreme heat or cold does not affect the ballistic inserts.

Fording and Swimming

Swimming or fording while wearing the Plate Carrier could be fatal because of the weight of the system. Before swimming or fording, doff the Plate Carrier by using either the normal or cable release methods.

Interim Chemical, Biological, Radiological and Nuclear (CBRN) Decontamination Procedures

If the Plate Carrier is exposed to any Chemical, Biological, Radiological, and Nuclear (CBRN) elements dispose of it in accordance with FM 3.11.3.

END OF WORK PACKAGE

CHAPTER 3

**PREVENTITIVE MAINTENANCE CHECKS
AND SERVICES
FOR
SOLDIER PLATE CARRIER SYSTEM**

OPERATOR MAINTENANCE**SOLDIER PLATE CARRIER SYSTEM**

PREVENTIVE MAINTENANCE CHECKS AND SERVICES (PMCS) – INTRODUCTION

INTRODUCTION

Preventive Maintenance Checks and Services (PMCS) are performed to keep clothing items in good serviceable condition and ready for issue. Pay attention to **WARNING**, **CAUTION**, and **NOTE** statements. A **WARNING** indicates that someone could be hurt or killed. A **CAUTION** indicates that equipment could be damaged. A **NOTE** may make your maintenance or repair task easier.

Be sure to perform scheduled PMCS. Always perform PMCS in the same order so it becomes habit. With practice, you will quickly recognize problems with the equipment.

Use DA Form 2404, Equipment Inspection and Maintenance Worksheet, to record any discovered faults. Do not record faults that you fix!

PMCS PROCEDURES

Table 1. Preventive Maintenance Checks and Services (PMCS). Lists inspections and care required to keep your equipment in good operating condition. It is arranged so that you can perform before operation checks as you walk around the equipment.

EXPLANATION OF PMCS TABLE COLUMNS:

Item Number. Indicates the reference number. When completing DA Form 2404, Equipment Inspection and Maintenance Worksheet, include the item number for the item to check/service indicating a fault. Item numbers appear in the order you must perform the checks/services listed.

Interval. Indicates when you must perform the procedure in the procedure column.

Before - perform before equipment operation

During - perform during equipment operation

After - perform after equipment has been operated

Monthly - perform each month

Annually - perform each year

Item to Check/Service. Indicates the item to be checked or serviced.

PMCS PROCEDURES – CONTINUED

Procedure. Indicates the procedure you must perform on the item listed in Item to Check/Service column. You must perform the procedure at the time specified in the Interval column.

Not Fully Mission Capable If. Indicates faults which will prevent your equipment from performing its primary mission. If you perform procedures listed in Procedure column which show faults listed in this column, do not operate the equipment. Follow standard procedures for maintaining the equipment or reporting equipment failure.

Other Special Entries. Observe all special information and notes that appear in Table 1.

When a check/service procedure is required for both weekly and before intervals, it is not necessary to perform the procedure twice if the equipment is operated during the weekly period.

COMMON CHECKS AND CLEANING**Cleaning**

Observe the cleanliness of clothing articles as part of the item's serviceability. Remove loose dirt, sand, and debris from all items.

END OF WORK PACKAGE

**OPERATOR MAINTENANCE
SOLDIER PLATE CARRIER SYSTEM
PREVENTIVE MAINTENANCE CHECKS AND SERVICES (PMCS)**

INITIAL SETUP**References:**WP 0011

General

Preventive maintenance checks and services (PMCS) are performed to keep the Soldier plate carrier system in operating condition. The checks are used to find, correct, and report problems. The operator is to do the PMCS tasks shown in PMCS.

Table 1. PMCS is to be done before and after use of the plate carrier and monthly.

Before you use the plate carrier, perform PMCS.

After you have used the plate carrier, perform PMCS.

PMCS Column Description

Column (1) ITEM NO. The order the PMCS should be performed.

Column (2) INTERVAL. Tells when the check should be performed.

Column (3) ITEM TO BE CHECKED OR SERVICED. Tells which items to perform the PMCS procedure on.

Column (4) PROCEDURE. Tells which procedure is to be performed. If item cannot be repaired, it must be replaced.

Column (5) EQUIPMENT NOT READY/AVAILABLE IF. Tells what conditions render the plate carrier unfit to perform the mission.

PMCS PROCEDURES

Table 1. Preventive Maintenance Checks and Services for the Soldier Plate Carrier System (SPCS).

ITEM NO.	INTERVAL	ITEM TO BE CHECKED OR SERVICED	PROCEDURE	EQUIPMENT NOT READY/AVAILABLE IF
1	Before After	Plate Carrier	<p>Soldier Inspect plate carrier.</p> <ul style="list-style-type: none"> a. Inspect the interior and exterior fabric of the vest for any cuts, frays or abrasions, or any damage that may interfere with the proper function of the body armor. b. Inspect the interior and exterior fabric of the vest for any dirt, stains or debris. Brush off any dirt or debris with a brush or rag. Clean in accordance with WP 0011. c. Run hands over entire surface of body armor to ensure soft ballistic inserts are flat. Smooth out any folds or bunching (Figure 1). 	<p>Any cuts, frays or abrasions, or any damage that may interfere with the proper function of the body armor.</p> <p>Any petroleum-based stains.</p> <p>Cannot be flattened.</p>

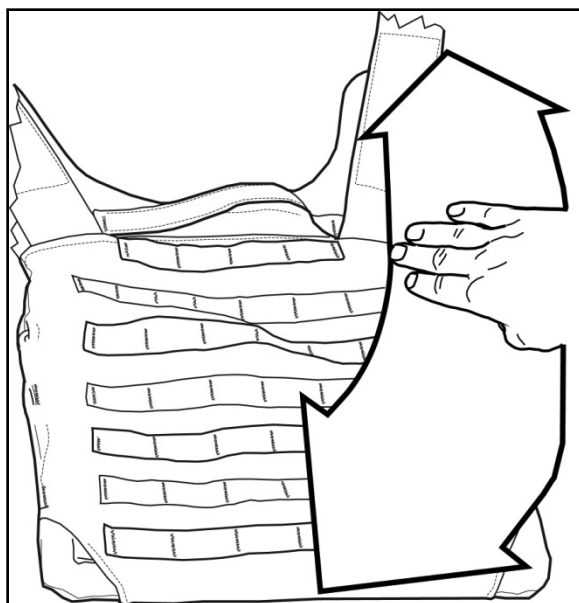

Figure 1. Smoothing Out Plate Carrier.

PMCS PROCEDURES – CONTINUED

Table 1. Preventive Maintenance Checks and Services for the SPCS – Continued.

ITEM NO.	INTERVAL	ITEM TO BE CHECKED OR SERVICED	PROCEDURE	EQUIPMENT NOT READY/AVAILABLE IF
	Before After	Plate Carrier – Continued	<p>d. Check the security of all hook and loop fastener tape.</p> <p>e. Inspect the shoulder straps and side plate carriers or attachment straps for any cuts, frays or abrasions or any damage that may interfere with the proper function of the body armor.</p> <p>f. Inspect the four quick release buckles for any damage that may interfere with the proper function of the body armor.</p> <p>g. Inspect the quick release cable for any damage or kinks.</p> <p>h. If there is damage to the carriers, check the soft ballistic inserts and PE plastic sheet for cuts, holes, wear and tear, contamination, and damage (Figure 2).</p>	<p>Hook and loop fastener tape does not function.</p> <p>Any cuts, frays or abrasions, or any damage that may interfere with the proper function of the body armor.</p> <p>Any damage that may interfere with the proper function of the body armor.</p> <p>Any damage that may interfere with the proper function of the quick release cable.</p> <p>Any damage that would interfere with the proper function or compromise the performance and/or service life of the equipment.</p>



Figure 2. Front/Back Carrier Soft Ballistic Insert, Side Pocket/Side Plate Carrier Soft Ballistic Insert, Cummerbund Soft Ballistic Insert and Polyethylene Plastic Insert (from left to right).

PMCS PROCEDURES – CONTINUED

Table 1. Preventive Maintenance Checks and Services for the SPCS – Continued.

ITEM NO.	INTERVAL	ITEM TO BE CHECKED OR SERVICED	PROCEDURE	EQUIPMENT NOT READY/AVAILABLE IF
	Before After	Plate Carrier – Continued	i. Check the security of all hook-and-loop fastener tape. j. Inspect the shoulder straps and side plate carriers or attachment straps for any cuts, frays or abrasions or any damage that may interfere with the proper function of the body armor.	Hook-and-loop fastener tape does not function. Any cuts, frays or abrasions, or any damage that may interfere with the proper function of the body armor. a.
2	Before	Cable Release	Second Soldier Check for proper cable release routing. a. Open panel on front carrier and reach underneath to feel the cable routing with your fingers (Figure 3).	

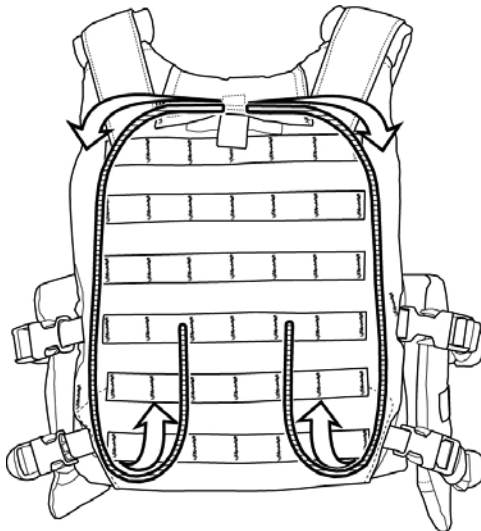

Figure 3. Cable Release Routing (Cable Shown on Top of Vest for Clarity).

PMCS PROCEDURES – CONTINUED

Table 1. Preventive Maintenance Checks and Services for the SPCS – Continued.

ITEM NO.	INTERVAL	ITEM TO BE CHECKED OR SERVICED	PROCEDURE	EQUIPMENT NOT READY/AVAILABLE IF
	Before	Cable Release – Continued	b. Ensure that the loop of the shoulder strap is routed through the metal slide and that the cable is routed through the loop (Figure 4).	
Figure 4. Shoulder Strap through Tri-Glide Slide.				
			c. Ensure the cables are not crossing and run freely through the vest, and that the cable is not taped, tied or otherwise secured to the plate carrier. Remove any tape or ties and adjust as necessary.	

PMCS PROCEDURES – CONTINUED

Table 1. Preventive Maintenance Checks and Services for the SPCS – Continued.

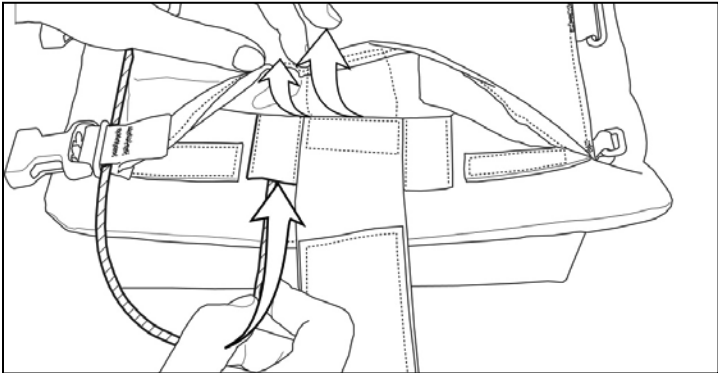
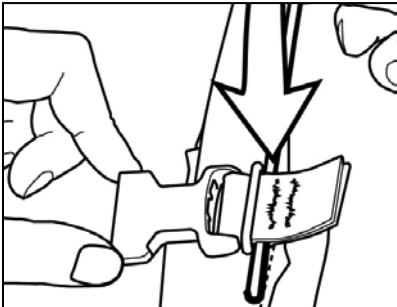
ITEM NO.	INTERVAL	ITEM TO BE CHECKED OR SERVICED	PROCEDURE	EQUIPMENT NOT READY/AVAILABLE IF
	Before	Cable Release – Continued	<p>d. Ensure each cable routes through the shoulder webbing loop on each side of the front carrier, through the two quick release buckles, and into the cable retainer channel underneath the ESAPI/XSAPI pocket (Figure 5).</p>	
				
<p>Figure 5. Cable Retainer Channel.</p>				
			<p>e. Ensure that the cable, when routing through the quick release buckles, is to the inside of the metal rings (Figure 6).</p>	
				
<p>Figure 6. Proper Arrangement of Quick Release Buckle and Quick Release Cable.</p>				
			<p>f. Reseal front flap.</p>	

PMCS PROCEDURES – CONTINUED

Table 1. Preventive Maintenance Checks and Services for the SPCS – Continued.

ITEM NO.	INTERVAL	ITEM TO BE CHECKED OR SERVICED	PROCEDURE	EQUIPMENT NOT READY/AVAILABLE IF
3	Before	Hard Armor Plates	<p>Soldier</p> <p>Inspect hard armor plates (Figure 7). Turn in plates if any conditions in the EQUIPMENT NOT READY/AVAILABLE IF column are found.</p>	<ul style="list-style-type: none"> a. Outer cover is damaged exposing the ceramic tile material. b. Plate is cracked and you hear loose pieces rattling around when shaken. c. Creaking or squeaking of ceramic tile heard when plate twisted by hand. d. Composite backing is delaminating (backing material plies are separating). e. Cracking of the ceramic tile is felt or heard as you firmly pinch the outer 1/2-inch perimeter of the plate. f. Plate has been hit by a bullet or fragment. g. Plate has a sticker that says FOR TRAINING PURPOSES ONLY.



Figure 7. Inspect Plates.

PMCS PROCEDURES – CONTINUED**Table 1. Preventive Maintenance Checks and Services for the SPCS – Continued.**

ITEM NO.	INTERVAL	ITEM TO BE CHECKED OR SERVICED	PROCEDURE	EQUIPMENT NOT READY/AVAILABLE IF
4	Before	Back Carrier	Second Soldier Check for proper nylon webbing and snap connections.	Any snaps cannot be snapped, any webbing cannot be properly threaded through buckles.
5	Before	Plate Carrier	Soldier Ensure all components are attached to plate carrier per unit SOP.	
6	After	Plate Carrier	a. Store the plate carrier system as flat as possible to avoid bunching of materials. b. It is recommended that the plate carrier, when dry, be stored in a plastic bag to keep out dirt, dust and moisture.	

END OF TASK**MANDATORY REPLACEMENT PARTS**

There are no mandatory replacement parts for the soldier plate carrier system.

END OF TASK**END OF WORK PACKAGE**

CHAPTER 4

MAINTENANCE INSTRUCTIONS
FOR
SOLDIER PLATE CARRIER SYSTEM

**OPERATOR MAINTENANCE
SOLDIER PLATE CARRIER SYSTEM
SERVICE – CLEANING AND DRYING**

INITIAL SETUP

Not applicable

GENERAL CLEANING INSTRUCTIONS**WARNING**

Failure to follow all cleaning instructions could deteriorate damage or destroy the plate carrier, rendering it useless against ballistic threats.

To maintain your plate carrier so that it provides you with the maximum protection intended, it is extremely important to follow proper cleaning procedures. Do not bleach, machine wash, dry clean, or apply solvents, cleaning fluids, or yellow soap to any part of the plate carrier. They will discolor and/or deteriorate the plate carrier. Do not attempt to dye item or fix discolorations.

Plate Carrier Vest and Components**WARNING**

Do not machine wash or dry the plate carrier. Failure to follow these instructions may render your plate carrier useless against ballistic threats.

CAUTION

Do not use a stiff brush to clean any part of your plate carrier as this will damage the material.

1. Remove loose dirt and lint from the outer shell using a cloth or soft bristle brush. Never use a stiff bristle brush.
2. Remove all soft ballistic inserts and the hard armor plates from the outer shell and component carriers.

GENERAL CLEANING INSTRUCTIONS – CONTINUED**CAUTION**

Never use bleach, yellow soap, cleaning fluids or solvents to clean the outer shell as these products will stain and damage the material.

3. Hand-wash the outer shell and component carrier covers in cold or warm water, with mild detergent or soap.
4. Badly soiled areas may be scrubbed with a soft cloth or soft brush. Scrub only long enough to remove soil.
5. Grease and oil stains may be pre-spotted with a mild detergent and water mixture, and scrubbed with a soft brush. If stubborn stain persists, repeat the procedure.
6. Rinse the outer shell and covers thoroughly in clean, warm water until suds are completely gone.
7. Air-dry indoors or in shade, away from heat sources and direct sunlight.

END OF TASK**Soft Ballistic Inserts****WARNING**

Do not machine wash or dry the soft ballistic inserts. Failure to follow these instructions may render the plate carrier useless against ballistic threats.

CAUTION

Do not intentionally submerge soft inserts in any liquid, including water. Do not use a stiff brush to clean any part of your plate carrier, as this will damage the material.

Cleaning of the soft ballistics inserts is limited to removing loose dirt from the surface with a cloth or soft brush. If ballistic inserts become wet, allow to air dry in a flat position away from heat sources and direct sunlight. If ballistic insert becomes saturated with liquids such as gasoline, bleach or other lubricants, turn in for replacement as soon as possible.

END OF TASK

ESAPI/ESBI and XSAPI/XSBI**WARNING**

Do not machine wash or dry the hard armor plates. Failure to follow these instructions will degrade the hard armor plates ballistic protection.

CAUTION

Do not submerge the hard armor plates in any liquid, including water.

Do not use a stiff brush to clean any part of your plate carrier as this will damage the material.

1. Remove loose dirt and lint from the outer surface of the ESAPI/ESBI or XSAPI/XSBI using a cloth or soft bristle brush. Never use a stiff bristle brush.
2. Wet the hard armor plates in a sink or shower using warm, not hot, water.
3. Apply a mild soap or detergent to the soiled areas and scrub with a cloth or soft bristle brush.
4. Badly soiled areas may be scrubbed with mild soap or detergent.
5. Scrub only long enough to remove soil.
6. Rinse the hard armor plates with warm water until all suds are completely gone.
7. Let the insert dry by itself, away from heat or open flame.

END OF TASK**END OF WORK PACKAGE**

**OPERATOR MAINTENANCE
SOLDIER PLATE CARRIER SYSTEM
CARRIER REPLACE**

INITIAL SETUP**References**WP 0005

REPLACE FRONT, BACK, AND SIDE CARRIERS

Assemble the new front and back carriers (and side carriers if used) in accordance with WP 0005.

Remove Soft Ballistic Inserts and Hard Armor Plates from Old Carriers

1. Remove ESAPI/XSAPI plates from the front and back carriers, if installed.
 - a. Open the main compartment of the front carrier by separating the hook and loop fastener.
 - b. Open the ESAPI/XSAPI pocket by pulling the pull-tab.
 - c. Pull out the ESAPI/XSAPI plate from the ESAPI/XSAPI compartment (Figure 1).



Figure 1. Removing ESAPI/XSAPI from ESAPI/XSAPI Pocket..

REPLACE FRONT, BACK, AND SIDE CARRIERS – CONTINUED

- d. Repeat steps a. through c. to remove the ESAPI/XSAPI plate from the back carrier.
2. Remove ESBI/XSBI plates from side carriers, if installed.
 - a. Open the side plate carrier pocket.
 - b. Pull out the ESBI/XSBI plate (Figure 2).



Figure 2. Removing ESBI/XSBI from Side Plate Carrier.

- c. Repeat steps a. and b. to remove the ESBI/XSBI plate from the other side plate carrier.
3. Remove the soft ballistic inserts from front, back, and side carriers.
 - a. Open the soft ballistic insert pocket of the front carrier by separating the hook and loop fastener.
 - b. Pull out the soft ballistic insert (Figure 3).
 - c. Repeat steps a. and b. to remove the soft ballistic inserts from the back carrier and both side plate carriers.

REPLACE FRONT, BACK, AND SIDE CARRIERS – CONTINUED

Figure 3. Removing Soft Ballistic from Front Carrier.

END OF TASK**Install Soft Ballistic Inserts and Hard Armor Plates into New Carriers**

1. Place the front carrier on a clean surface with the exterior surface facing down.
2. Open the soft ballistic insert pocket by separating the hook and loop fastener (Figure 4).



Figure 4. Opening Soft Ballistic Insert Pocket on Front Carrier.

REPLACE FRONT, BACK, AND SIDE CARRIERS – CONTINUED

3. Fold the soft ballistic insert at the sides and slide it all the way into the carrier with the data label facing up (Figure 5).



Figure 5. Inserting Soft Ballistic into Front Carrier.

4. Reach into the carrier and smooth the insert to make sure it is lying flat and flush with the edges.
5. Tuck the bottom of the insert into the compartment and seal the hook and loop closure.
6. Repeat steps 1 through 5 to install soft ballistic inserts into the back carrier and both side plate carriers.

Install Hard Armor ESAPI/XSAPI Plates

1. Lay the front carrier on a flat surface with the exterior facing up.

REPLACE FRONT, BACK, AND SIDE CARRIERS – CONTINUED

2. Lift the outer cover of the front carrier by separating the hook and loop tape on the underside of the carrier and flipping the cover up (Figure 6).



Figure 6. Opening Outer Cover of Front Carrier.

3. Pull the tab on the hook and loop fastener to expose the ESAPI/XSAPI pocket (Figure 7).



Figure 7. Opening ESAPI/XSAPI Pocket.

REPLACE FRONT, BACK, AND SIDE CARRIERS – CONTINUED

4. Insert ESAPI/XSAPI into the pocket with data label facing the body, strike face side up (Figure 8).

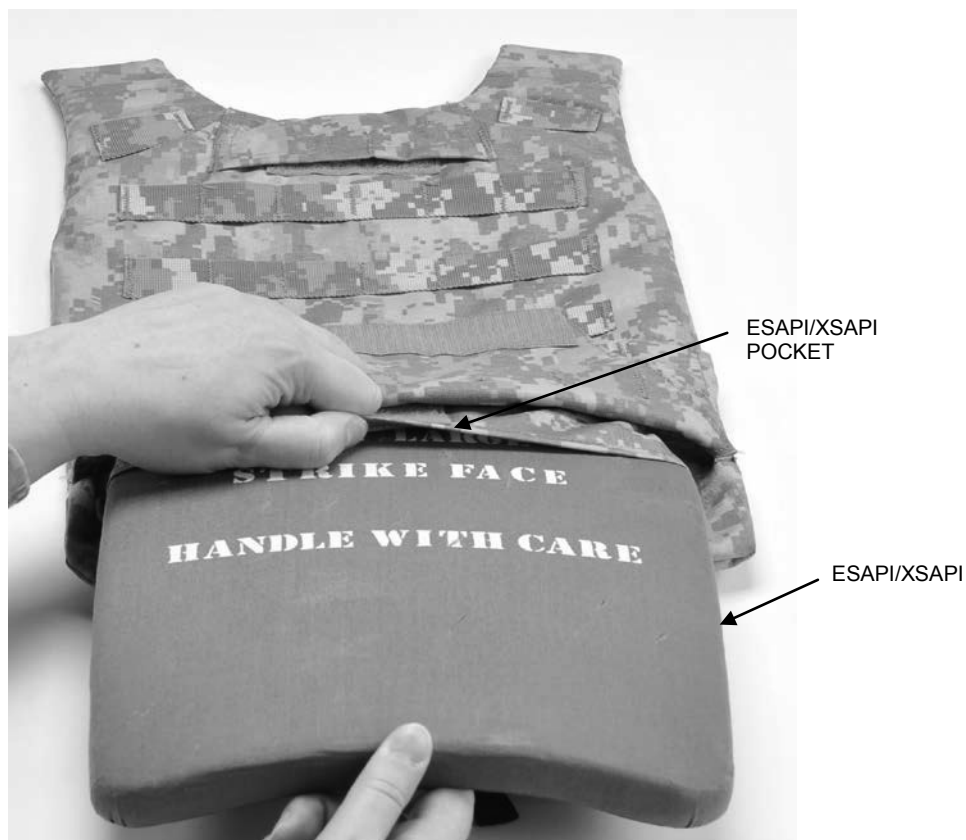

Figure 8. Inserting ESAPI/XSAPI.

5. Reattach the hook and loop fastener to close the ESAPI/XSAPI pocket.
6. Tighten the webbing enough to hold the hard armor in the pocket firmly in place with no slipping.
7. Close the top cover flap and seal the hook and loop fastener tape.
8. Repeat steps 1 through 7 to install the ESAPI/XSAPI into the back carrier.

Install Hard Armor ESBI/XSBI Plates (Side Plate Carrier Configuration)

1. Place the side plate carrier on a clean surface with the exterior surface facing down.
2. Unfasten the hook and loop fastener on the exterior flap.

REPLACE FRONT, BACK, AND SIDE CARRIERS – CONTINUED

3. Slide the ESBI/XSBI into the compartment with the data label facing up and the strike side down (Figure 9).



Figure 9. Inserting ESBI/XSBI under Compartment for Soft Ballistic.

4. Fold the flap of the compartment over the ESBI/XSBI and reattach the hook and loop fastener.
5. Repeat steps 1 through 4 to install the ESBI/XSBI in the other side plate carrier.

END OF TASK

END OF WORK PACKAGE

**OPERATOR MAINTENANCE
SOLDIER PLATE CARRIER SYSTEM
SIDE PLATE CARRIER REPLACE**

INITIAL SETUP**References**

WP 0002
WP 0005

REPLACE SIDE PLATE CARRIER

The angled straps of the earlier side plate carriers are permanently attached to the side plate carriers. More recent side plate carriers have detachable angled T-straps. For more information, see WP 0002 Equipment Description and Data.

Remove Old Side Plate Carrier

1. Detach quick release buckles from front carrier, if attached (Figure 1).



Figure 1. Detaching Quick Release Buckles.

2. Detach the angled strap, upper strap, and lower strap of the side plate carrier from the back carrier at the metal snaps (Figure 2).



Figure 2. Detaching Side Plate Carrier Snaps from Back Carrier.

REPLACE SIDE PLATE CARRIER – CONTINUED

3. Open the old side plate carrier and remove the ESBI/XSBI plate, if installed, and the soft ballistic insert.

Attach New Side Plate Carrier to Back Carrier

1. Place the new side plate carrier on a clean surface with the data label facing up.
2. Open the compartment for the soft ballistic by separating the hook and loop fastener on the exterior flap and then separating the hook and loop on the interior flap.
3. Fold the soft ballistic insert at the sides and slide it all the way into the carrier with the data label facing up (Figure 3).



Figure 3. Inserting Soft Ballistic.

WARNING

Make sure the ESBI/XSBI plate is in the exterior compartment and the soft ballistic insert is in the interior compartment. The soft ballistic must be closest to the body when the vest is worn. Failure to do so will affect the amount of protection provided resulting in injury or death to personnel.

4. Place the ESBI/XSBI plate (if used) in the second compartment below the soft ballistic with the data label facing up.

REPLACE SIDE PLATE CARRIER – CONTINUED

5. Lay the back carrier down on a clean surface with the exterior facing up.
6. Lift the cover of the back carrier by separating the hook and loop tape on the underside of the carrier to allow access to the side plate carrier attachment points (Figure 4).



Figure 4. Opening the Back Carrier.

7. Attach the angled t-strap to the side plate carrier if it is not already attached in accordance with WP 0005.

REPLACE SIDE PLATE CARRIER – CONTINUED

8. Reach into the back carrier and pull out the angle strap attachment D-ring (Figure 5).



Figure 5. Pulling Out the Angled SPC Strap Attachment D-Ring from Back Carrier.

9. Take the end of the angled SPC strap that has the snap on it, thread through the D-ring, and snap it closed (Figure 6).



Figure 6. Attaching Angled T-Strap to D-Ring.

REPLACE SIDE PLATE CARRIER – CONTINUED

10. Double the strap back through the tri-glide buckle before stowing the excess strap and buckle inside the back carrier excess back inside the vest (Figure 7).



Figure 7. Tucking Extra Webbing into Back Carrier.

11. Insert the middle SPC strap into the slot on the back carrier (Figure 8).



Figure 8. Inserting Middle SPC Strap.

REPLACE SIDE PLATE CARRIER – CONTINUED

12. Take the end of the middle SPC strap that has the snap on it, insert it through the middle metal loop on the back carrier (with the metal loop on the strap facing up) and snap it closed (Figure 9).



Figure 9. Attaching the Middle SPC Strap to Back Carrier.

13. Adjust the length of the strap using the tri-glide slide if necessary.
14. Double the strap back through the tri-glide slide before stowing the excess strap and slide inside the back carrier.
15. Take the lower SPC strap end that has the snap on it, insert it through the lower metal loop on the back carrier (with the metal loop on the strap facing up) and snap it closed (Figure 10).



Figure 10. Attaching Lower SPC Strap to Back Carrier.

REPLACE SIDE PLATE CARRIER – CONTINUED

16. Adjust the length of the strap using the tri-glide slide if necessary.
17. Double the strap back through the tri-glide slide before stowing the excess strap and buckle inside the back carrier.

END OF TASK

END OF WORK PACKAGE

**OPERATOR MAINTENANCE
SOLDIER PLATE CARRIER SYSTEM
CUMMERBUND ASSEMBLY REPLACE**

INITIAL SETUP**References**

WP 0002
WP 0006

REPLACE CUMMERBUND ASSEMBLY

The cummerbund assembly is made up of three components: cummerbund carrier, side plate pocket, angled T-strap, soft ballistic for the cummerbund, hard plastic stiffener for the cummerbund, and soft ballistic for the side plate pocket. For more information, see WP 0002 Equipment Description and Data.

Remove Old Cummerbund

1. Detach quick release buckles from front carrier, if attached (Figure 1).



Figure 1. Detaching Quick Release Buckles.

2. Detach the angled strap, upper strap, and lower strap of the side plate carrier from the back carrier at the metal snaps (Figure 2).



Figure 2. Detaching Cummerbund Assembly from Back Carrier.

REPLACE CUMMERBUND ASSEMBLY - CONTINUED

3. Detach the angled strap, upper strap, and lower strap of the side plate carrier from the back carrier at the metal snaps (Figure 2).
4. Detach the side plate pocket from the cummerbund.
5. Open the old side plate pocket and remove the EXSBI/XSBI plate, if installed, and the soft ballistic insert.
6. Open the old cummerbund and remove the soft ballistics and plastic stiffener.

Attach New Cummerbund Assembly to Back Carrier**NOTE**

When inserting soft ballistics and hard armor protective inserts, make sure that all labels face in the same direction as the labels on the carrier.

1. Insert the soft ballistics in the inner compartment of the new side plate pockets in accordance with WP 0006.
2. Insert the soft ballistics in the cummerbund and slide the plastic stiffener in on top of the soft ballistic in accordance with WP 0006.
3. Attach the angled t-straps to the cummerbund if they are not already attached in accordance with WP 0006.
4. Attach the side plate pockets to the cummerbund in accordance with WP 0006.
5. Position one section of the cummerbund beside the back carrier as shown in Figure 3.

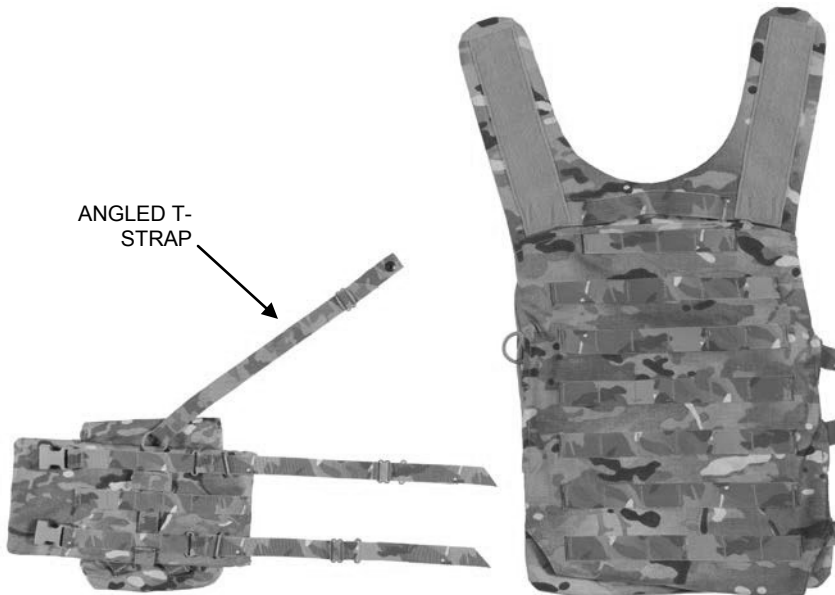

Figure 3. Positioning Assembled Cummerbund for Attachment.

REPLACE CUMMERBUND ASSEMBLY - CONTINUED

6. Open the bottom flap of the back carrier.
7. Reach in the back carrier and push the D ring out from inside the back carrier to the outside (Figure 4).

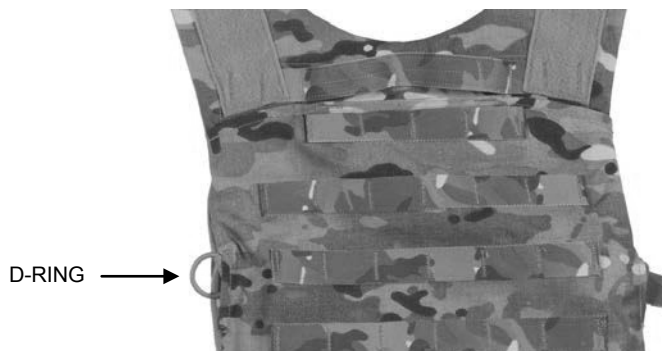

Figure 4. Pull D-Ring through to Outside of Back Carrier.

8. Insert the snap end of the angle strap through the D ring and snap the fastener closed. Tuck the D-Ring back into the back carrier (Figure 5).



Figure 5. Insert Snap End of Angle Strap through D-Ring.

REPLACE CUMMERBUND ASSEMBLY - CONTINUED

9. Insert the TOP strap of the cummerbund into the middle slot of the back carrier, as shown in Figure 6.

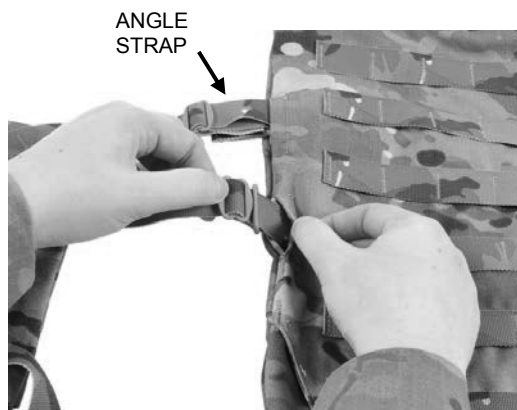

Figure 6. Top Strap of Cummerbund Inserted in Back Carrier.

10. Thread the snap end through the middle metal loop on the back carrier (with the metal loop on the strap facing up) and snap it closed (Figure 7).



Figure 7. Insert Snap End through Inside Metal Slide.

11. Adjust the length of the strap using the tri-glide slide if necessary.

REPLACE CUMMERBUND ASSEMBLY - CONTINUED

12. Insert the lower strap of the cummerbund into the lower slot of the back carrier, as shown in Figure 8.



Figure 8. Left Cummerbund Attached to Back Carrier

13. Thread the snap end through the lower metal loop on the back carrier (with the metal loop on the strap facing up) and snap it closed.
14. Adjust the length of the strap using the tri-glide slide if necessary
15. Repeat steps 5 through 15 to attach the other side of the cummerbund to the back carrier.
16. Close the hook and loop fastener on the back carrier.



Figure 9. Back Carrier with Cummerbund Assembly Installed.

REPLACE CUMMERBUND ASSEMBLY - CONTINUED**WARNING**

Make sure the ESBI/XSBI plate is in the exterior compartment and the soft ballistic insert is in the interior compartment. The soft ballistic must be closest to the body when the vest is worn. Failure to do so will affect the amount of protection provided resulting in injury or death to personnel.

17. Place the ESBI/XSBI plate (if used) in the second compartment of the side plate pocket in accordance with WP 0006.

END OF TASK**END OF WORK PACKAGE**

**OPERATOR MAINTENANCE
SOLDIER PLATE CARRIER SYSTEM
SHOULDER STRAP REPLACE**

INITIAL SETUP**References**

WP 0005

REPLACE SHOULDER STRAP**Remove Old Shoulder Strap**

1. Pull the quick release cable entirely out of one side of the vest (Figure 1).



Figure 1. Pulling Out the Quick Release Cable.

2. Pull the shoulder strap apart from the front carrier.

REPLACE SHOULDER STRAP – CONTINUED

3. Detach the shoulder strap from the back carrier at the tri-glide slide (Figure 2).



Figure 2. Detaching Shoulder Strap from Back Carrier Buckle.

4. Detach the shoulder strap from the back carrier at the hook and loop fastener. The shoulder strap should now be completely separated.

Attach New Shoulder Strap

1. Insert the cable ends through the hole on the side of the cable release pocket (Figure 3).



Figure 3. Insert Cable End through Hole in Cable Release Pocket.

REPLACE SHOULDER STRAP – CONTINUED

2. Pull the cable through so the pull-tab is centered on the loop fastener.
3. Thread the 2-inch nylon webbing of the shoulder strap through the tri-glide slide on the back carrier (Figure 4).



Figure 4. Attaching Shoulder Strap to Back Carrier.

4. Stow the excess strap and buckle inside the back carrier.
5. Double the strap back through the tri-glide slide before stowing the excess strap and buckle inside the back carrier.

NOTE

For Figures 5 through 10, the front carrier is shown inside-out to better illustrate the procedures. During actual assembly, most of the attachment points on the front carrier are not visible. The procedures must be performed by touch.

REPLACE SHOULDER STRAP – CONTINUED

6. Insert the looped end of the 2-inch nylon webbing of the shoulder strap through the slot on the metal slide inside the front carrier (Figure 5).

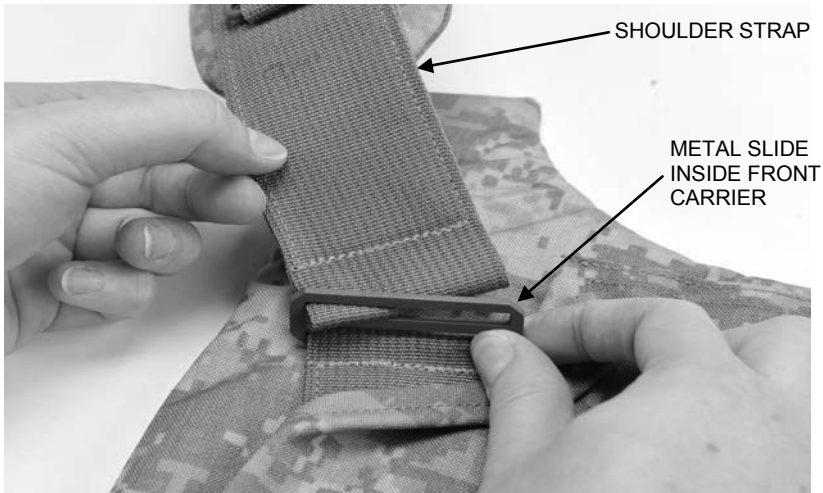

Figure 5. Inserting Shoulder Strap through Tri-Glide Slide on Front Carrier.

7. Thread the cable through the loop on the end of the shoulder strap from the center of the vest toward the outside (Figure 6).



Figure 6. Threading the Cable through the Shoulder Strap Loop (Interior View).

REPLACE SHOULDER STRAP – CONTINUED

7. Continue threading the remaining quick release cable in accordance with WP 0005.

END OF TASK

END OF WORK PACKAGE

**OPERATOR MAINTENANCE
SOLDIER PLATE CARRIER SYSTEM
QUICK RELEASE CABLE REPLACE**

INITIAL SETUP**References**

WP 0005

REPLACE QUICK RELEASE CABLE

1. Pull out the old quick release cable entirely, if installed (Figure 1).



Figure 1. Pulling Out the Quick Release Cable.

2. Thread the new quick release cable through the plate carrier in accordance with WP 0005.

END OF TASK**END OF WORK PACKAGE**

**OPERATOR MAINTENANCE
SOLDIER PLATE CARRIER SYSTEM
QUICK RELEASE BUCKLE REPLACE**

INITIAL SETUP**References**

WP 0005

REPLACE QUICK RELEASE BUCKLE**Remove Old Quick Release Buckle**

1. Pull out the quick release cable far enough to free the buckle being replaced.
2. Pull the buckle out of the metal loop on the front carrier.

END OF TASK**Install New Quick Release Buckle**

1. Insert the buckle through the metal rectangular ring inside the front carrier (Figure 1). If installing the top buckle, insert the nylon webbing through the hole in the side of the front carrier first, then through the ring.



Figure 1. Inserting Quick Release Buckle through Metal Ring.

REPLACE QUICK RELEASE BUCKLE – CONTINUED

2. Thread the release cable through the webbing of the quick release buckles, from the top of the vest toward the bottom (Figure 2).

WARNING

Ensure the quick release cable is located to the inside side of the metal rectangular ring (closer to the center of the front carrier). Failure to do so could adversely affect the function of the quick-release, causing injury or death to personnel.



Figure 2. Threading the Cable through the Quick Release Buckles.

3. Continue threading the remaining quick release cable in accordance with WP 0005.

END OF TASK

END OF WORK PACKAGE

**OPERATOR MAINTENANCE
SOLDIER PLATE CARRIER SYSTEM
SOFT BALLISTIC INSERT REPLACE**

INITIAL SETUP

Not Applicable

REPLACE SOFT BALLISTIC INSERT**NOTE**

The procedure for replacing a soft ballistic insert in the side plate carriers, cummerbund and pockets, and back carrier is the same as for the front carrier.

1. Place the front carrier on a clean surface with the exterior surface facing down.
2. Open the soft ballistic insert pocket by separating the hook and loop fastener (Figure 1).



Figure 1. Opening Pocket for Soft Ballistic Insert.

3. Pull out the existing soft ballistic insert.
4. Take the new soft ballistic insert, fold the sides up slightly, and slide it all the way into the carrier with the data label facing up (Figure 2).

REPLACE SOFT BALLISTIC INSERT – CONTINUED

Figure 2. Inserting Soft Ballistic into Front Carrier.

5. Reach into the carrier and smooth the insert to make sure it is lying flat and flush with the edges.
6. Tuck the bottom of the insert into the compartment and seal the hook and loop closure.

Repeat steps 1 through 6 to replace the soft ballistic inserts into the back carrier and both side plate carriers, if necessary.

END OF TASK

END OF WORK PACKAGE

OPERATOR MAINTENANCE
SOLDIER PLATE CARRIER SYSTEM
HARD ARMOR PLATES
INSPECT, REPAIR

INITIAL SETUP**Materials/parts:**

Tape, Pressure Sensitive Adhesive
(WP 0025, Item 5)

INSPECT**WARNING**

Personnel must ensure they have the correct protective inserts. The ESAPI and ESBI have green covers and the XSAPI and XSBI have tan covers. Both provide a higher level of protection than the Small Arms Protective Insert (SAPI) which has a black cover.

ESAPI or XSAPI and ESBI or XSBI should be worn by all personnel in-theater. If a service member has the older black SAPI plates, they should be turned in and replaced with green ESAPI/ESBI plates or tan XSAPI/XSBI plates. Failure to ensure the correct plate while conducting combat operations may result in injury or death.

Pre-combat Inspection

The Soldier must inspect the hard armor inserts before each mission. A hard armor insert must be turned in if any of the following conditions are present:

- Outer cover is damaged exposing the ceramic tile material.
- Plate is cracked and you hear loose pieces rattling around when shaken.
- Creaking or squeaking of ceramic tile heard when plate twisted by hand.
- Composite backing is delaminating (backing material plies are separating).

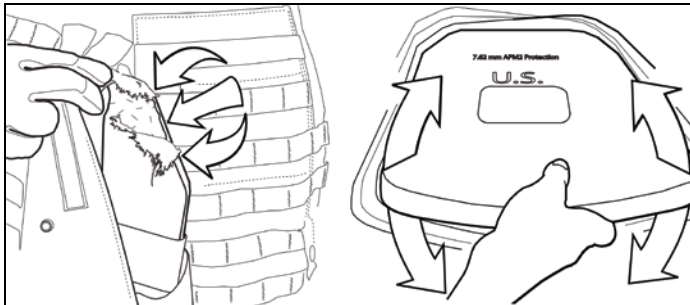

Figure 10. Inspect Plates.

INSPECT – CONTINUED

- Cracking of the ceramic tile is felt or heard as you firmly pinch the outer ½-inch perimeter of the plate.
- Plate has been hit by a bullet or fragment.

END OF TASK**REPAIR****NOTE**

Cloth backed adhesive tape is often referred to as duct tape, rigger's tape or 100 mile-per-hour tape.

Interim repairs of the hard armor plate outer cover can be made using cloth backed adhesive tape until it can be exchanged. This repair does help to prevent the spread of existing delamination. It is not meant as a permanent fix.

END OF TASK**END OF WORK PACKAGE**

**OPERATOR MAINTENANCE
SOLDIER PLATE CARRIER SYSTEM
FABRIC REPAIR**

INITIAL SETUP**Materials/parts:**

Kit, Sewing (WP 0025, Item 2)

Tape, Pressure Sensitive Adhesive (WP 0025, Item 5)

REPAIR**WARNING**

Fabric repair in this work package does not apply to the fabric on the soft ballistic inserts. Any damage to the soft ballistic inserts is cause for turn-in. Failure to follow these instructions could result in degraded ballistic protection.

This work package provides instructions for repairing the fabric of the plate carrier.

Outer Shell

1. To mend a ripped seam, overlap the two-edges and sew with straight and small stitches.



Figure 1. Straight Stitch.

2. To repair a tear, place the two edges together on the inside, and sew together.



Figure 2. Edge Sew.

REPAIR – CONTINUED

3. To mend a frayed edge, turn the frayed edge under and sew.



Figure 3. Turn Edge Under and Sew.

NOTE

Cloth backed adhesive tape is often referred to as duct tape, rigger's tape or 100 mile-per-hour tape.

4. Interim repairs can be made with cloth backed adhesive tape to prevent tears or holes in the carrier from expanding until the vest can be exchanged. The tape can be used to keep the vest closed, hold the ballistic panels in place, or repair any hook and pile that has been damaged.

END OF TASK

END OF WORK PACKAGE

**OPERATOR MAINTENANCE
SOLDIER PLATE CARRIER SYSTEM
PREPARATION FOR SHIPMENT AND STORAGE**

INITIAL SETUP

Not applicable

General Storage Requirements

Administrative storage will be in accordance with the following:

1. Clean all items and ensure they are dry before Plate Carrier is placed in storage. Store each individual Plate Carrier in a plastic bag to keep out dirt, dust and moisture. Placement of clothing items in administrative storage should be for short periods of time. Ensure all items are protected from pilferage, dampness, fire, dirt, and rodents.
2. Insert the hard armor plates into the Plate Carrier pockets in the same manner as when worn. This prevents loss of components. Store the Plate Carrier system as flat as possible to avoid bunching of materials.
3. Items should be in mission readiness within 24 hours or within the time factors as determined by the directing authority.
4. During the storage period, appropriate maintenance records will be kept. Before placing equipment in administrative storage, current maintenance services and equipment serviceable criteria evaluations should be completed, shortcomings and deficiencies should be corrected, and all modification work orders should be applied.
5. Inside storage is preferred for items selected for administrative storage. If inside storage is not available, trucks, vans, CONEX containers and other containers may be used.

In-Storage Inspection

1. Check that no damage or deterioration has occurred.
2. Check the adequacy of the storage facilities, efforts taken to control pests and rodents, and protection against unfavorable climatic conditions and other elements that might cause damage to clothing items.

Shipment Requirements

Ensure all items are protected from pilferage, dampness, fire, dirt, and rodents.

END OF WORK PACKAGE

CHAPTER 5

SUPPORTING INFORMATION
FOR
SOLDIER PLATE CARRIER SYSTEM

**OPERATOR MAINTENANCE
SOLDIER PLATE CARRIER SYSTEM
REFERENCES**

SCOPE

This work package lists related field manuals, forms, technical manuals, and miscellaneous publications.

ARMY REGULATION

AR 700-138 Army Logistics Readiness and Sustainability

COMMON TABLES

CTA 8-100 Army Medical Department Expendable/Durable Items
CTA 50-909 Field and Garrison Furnishings and Equipment
CTA 50-970 Expendable/Durable Items (Except Medical, Class V Repair Parts,
and Heraldic Items)

FIELD MANUALS

FM 3-11.3 Multiservice Tactics, Techniques, and Procedures for Chemical,
Biological, and Nuclear Contamination Avoidance
FM 4-25.11 First Aid Information

FORMS

DA Form 12-R Request for Establishment of a Publications Account
DA Form 2028 Recommended Changes to Publications and Blank Forms
DA Form 2404 Equipment Inspection and Maintenance Worksheet
SF 368 Product Quality Deficiency Report

PAMPHLETS

DA PAM 25-33 User's Guide for Army Publications and Forms
DA PAM 738-751 Functional Users Manual for the Army Maintenance Management
System (TAMMS-A)
DA PAM 750-8 The Army Maintenance Management System (TAMMS) Users
Manual

TECHNICAL MANUALS

TM 750-244-1-2 Procedures for the Destruction of Life Support Equipment to Prevent
Enemy Use

END OF WORK PACKAGE

**OPERATOR MAINTENANCE
SOLDIER PLATE CARRIER SYSTEM
COMPONENTS OF END ITEM (COEI) AND BASIC ISSUE ITEM (BII) LISTS**

COMPONENTS OF END ITEM (COEI) AND BASIC ISSUE ITEM (BII) LISTS**INTRODUCTION****SCOPE**

This work package lists COEI and BII for the Soldier Plate Carrier System to help you inventory items for safe and efficient operation of the equipment.

GENERAL

The COEI and BII information is divided into the following lists:

Components of End Item (COEI). This list is for information purposes only and is not authority to requisition replacements. These items are part of the Soldier Plate Carrier System. As part of the end item, these items must be with the end item whenever it is issued or transferred between property accounts. Items of COEI are removed and separately packaged for transportation or shipment only when necessary. Illustrations are furnished to help you find and identify the items.

Basic Issue Items (BII). These essential items are required to place the Plate Carrier in operation, operate it and to do emergency repairs. Although shipped separately packaged, BII must be with the Plate Carrier during operation and when it is transferred between property accounts. Listing these items is your authority to request/requisition them for replacement based on authorization of the end item by the TOE/MTOE. Illustrations are furnished to help you find and identify the items.

EXPLANATION OF COLUMNS IN THE COEI LIST AND BII LIST

Column (1) Item Number. Gives you the number of the item listed.

Column (2) National Stock Number (NSN) and illustration. Identifies the stock number of the item to be used for requisitioning purposes and provides an illustration of the item.

Column (3) Description, Part Number/(CAGEC). Identifies the Federal item name (in all capital letters) followed by a minimum description when needed. The stowage location of COEI and BII is also included in this column. The last line below the description is the part number and the Commercial and Government Entity Code (CAGEC) (in parentheses).

Column (4) Usable On Code. When applicable, gives you a code if the item you need is not the same for different models of equipment.

Column (5) U/I. Unit of Issue (U/I). Indicates the physical measurement or count of the item as issued per the National Stock Number shown in column (2).

Column (6) Qty Rqr. Indicates the quantity required.

**COMPONENTS OF END ITEM (COEI) AND BASIC ISSUE ITEM (BII) LISTS –
CONTINUED**
Table 1. Components of End Item (COEI) List.

(1) Item Number	(2) National Stock Number (NSN) and Illustration	(3) Description, Part Number/(CAGEC)	(4) Usable On Code	(5) U/I	(6) Qty Rqr
1	 8470-01-592-9461	SPCS COMPLETE VEST (WITH CUMMERBUND) (OCP), X-SMALL, AR/PD 10-04/(81337)		EA	1
1	8470-01-592-9468	SPCS COMPLETE VEST (WITH CUMMERBUND) (OCP), SMALL, AR/PD 10-04/(81337)		EA	1
1	8470-01-592-9479	SPCS COMPLETE VEST (WITH CUMMERBUND) (OCP), MEDIUM, AR/PD 10-04/(81337)		EA	1
1	8470-01-592-9480	SPCS COMPLETE VEST (WITH CUMMERBUND) (OCP), LARGE, AR/PD 10-04/(81337)		EA	1
1	8470-01-592-9484	SPCS COMPLETE VEST (WITH CUMMERBUND) (OCP), X-LARGE, AR/PD 10-04/(81337)		EA	1
1	8470-01-592-9485	SPCS COMPLETE VEST (WITH CUMMERBUND) (OCP), XX-LARGE, AR/PD 10-04/(81337)		EA	1
2	8470-01-599-2283	CUMMERBUND SYSTEM, LEFT (INCLUDES LEFT SIDE OUTERSHELL, 1 PE STIFFENER, 1 CUMMERBUND BALLISTIC INSERT, 1 SIDE PLATE POCKET), X-SMALL – SMALL, AR/PD 10-04/(81337)		EA	1
2	8470-01-599-2284	CUMMERBUND SYSTEM, LEFT (INCLUDES LEFT SIDE OUTERSHELL, 1 PE STIFFENER, 1 CUMMERBUND BALLISTIC INSERT, 1 SIDE PLATE POCKET), MEDIUM – LARGE, AR/PD 10-04/(81337)		EA	1

**OPERATOR MAINTENANCE
SOLDIER PLATE CARRIER SYSTEM
ADDITIONAL AUTHORIZATION LIST (AAL)**

ADDITIONAL AUTHORIZATION LIST (AAL)**INTRODUCTION****Scope**

This work package lists additional items you are authorized for the support of the Soldier Plate Carrier System.

General

This list identifies items that do not have to accompany the Plate Carrier and that do not have to be turned in with it. These items are all authorized to you by CTA, MTOE, TDA, or JTA.

Explanation of Columns in the AAL

Column (1) National Stock Number (NSN). Identifies the stock number of the item to be used for requisitioning purposes.

Column (2) Description, Part Number/(CAGEC). Identifies the Federal item name (in all capital letters) followed by a minimum description when needed. The last line below the description is the part number and the Commercial and Government Entity Code (CAGEC) (in parentheses).

Column (3) Usable On Code. When applicable, gives you a code if the item you need is not the same for different models of equipment.

Column (4) U/I. Unit of Issue (U/I) indicates the physical measurement or count of the item as issued per the National Stock Number shown in column (1).

Column (5) Qty Recm. Indicates the quantity recommended.

ADDITIONAL AUTHORIZATION LIST – CONTINUED

Table 1. Additional Authorization List.

(1) National Stock Number (NSN)	(2) Item Name, Description, Part Number/(CAGEC)	(3) Usable on Code	(4) U/I	(5) Qty Recom
8470-01-547-9555	X SMALL ARMS PROTECTIVE INSERT (XSAPI) SIZE XSMALL, FQ/PD 07-03/(81337)		SE	1
8470-01-547-9722	X SMALL ARMS PROTECTIVE INSERT (XSAPI) SIZE SMALL, FQ/PD 07-03/(81337)		SE	1
8470-01-547-9726	X SMALL ARMS PROTECTIVE INSERT (XSAPI) SIZE MEDIUM, FQ/PD 07-03/(81337)		SE	1
8470-01-547-9779	X SMALL ARMS PROTECTIVE INSERT (XSAPI) SIZE LARGE, FQ/PD 07-03/(81337)		SE	1
8470-01-547-9780	X SMALL ARMS PROTECTIVE INSERT (XSAPI) SIZE XLARGE, FQ/PD 07-03/(81337)		SE	1
8470-01-520-7360	ENHANCED SMALL ARMS PROTECTIVE INSERT (ESAPI) SIZE X-SMALL, CO/PD 04-10/(81337)		SE	1
8470-01-520-7370	ENHANCED SMALL ARMS PROTECTIVE INSERT (ESAPI) SIZE SMALL, CO/PD 04-10/(81337)		SE	1
8470-01-520-7373	ENHANCED SMALL ARMS PROTECTIVE INSERT (ESAPI) SIZE MEDIUM, CO/PD 04-10/(81337)		SE	1
8470-01-520-7385	ENHANCED SMALL ARMS PROTECTIVE INSERT (ESAPI) SIZE LARGE, CO/PD 04-10/(81337)		SE	1
8470-01-520-7382	ENHANCED SMALL ARMS PROTECTIVE INSERT (ESAPI) SIZE XLARGE, CO/PD 04-10/(81337)		SE	1

Table 1. Additional Authorization List – Continued.

(1) National Stock Number (NSN)	(2) Item Name, Description, Part Number/(CAGEC)	(3) Usable on Code	(4) U/I	(5) Qty Recom
8470-01-589-0176	X SIDE BALLISTIC INSERTS (XSBI) ONE SIZE, AR/PD 10-3A/(81337)		SE	1
8470-01-536-7227	ENHANCED SIDE BALLISTIC INSERT (ESBI) (PLATE) ONE SIZE, CO/PD 06-20/(81337)		SE	1

END OF WORK PACKAGE

**OPERATOR MAINTENANCE
SOLDIER PLATE CARRIER SYSTEM
EXPENDABLE AND DURABLE ITEMS LIST**

EXPENDABLE AND DURABLE ITEMS LIST

INTRODUCTION

Scope

This work package lists expendable and durable items that you will need to operate and maintain the Soldier Plate Carrier System. This list is for information only and is not authority to requisition the listed items. These items are authorized to you by CTA 50-970, Expendable/Durable Items (Except Medical, Class V Repair Parts, and Heraldic Items), CTA 50-909, Field and Garrison Furnishings and Equipments or CTA 8-100, Army Medical Department Expendable/Durable Items.

Explanation of Columns in the Expendable/Durable Items List

Column (1) Item No. This number is assigned to the entry in the list and is referenced in the narrative instructions to identify the item (e.g., Use brake fluid (WP 0098, item 5))

Column (2) Level. This column identifies the lowest level of maintenance that requires the listed item (C= *Crew*).

Column (3) National Stock Number (NSN). This is the NSN assigned to the item which you can use to requisition it.

Column (4) Item Name, Description, Part Number (CAGEC). This column provides the other information you need to identify the item. The last line below the description is the part number and the Commercial and Government Entity Code (CAGEC) (in parentheses).

Column (5) U/I. Unit of Issue (U/I) Code. Shows the physical measurement or count of an item, such as gallon, dozen, gross, etc.

EXPENDABLE AND DURABLES ITEMS LIST**Table 1. Expendable and Durable Items List**

(1) Item No.	(2) Level	(3) National Stock Number (NSN)	(4) Item Name, Description, Part Number/(CAGEC)	(5) U/I
1	C	N/A	Cleaning Foam System, Outer Vest, SOT0-10FC00NA05/(3D6J6)	BT
2	C	8315-01-222-0680	Kit, Sewing, A-A-55190 (58536)	EA
3	C	N/A	Patch, Outer Shell Field Repair, Type I, SOT0-10DE00CD01/(3D6J6)	PK
4	C	N/A	Patch, Outer Shell Field Repair, Type II, SOT0-10DE00CD02/(3D6J6)	PK
5	C	7510-00-266-5016	Tape, Pressure Sensitive Adhesive, PPP-T-60 (81348) or similar	RL

END OF WORK PACKAGE

These are the instructions for sending an electronic 2028

The following format must be used if submitting an electronic 2028. The subject line must be exactly the same and all fields must be included; however only the following fields are mandatory: 1, 3, 4, 5, 6, 7, 8, 9, 10, 13, 15, 16, 17, and 27.

From: "Whomever" <whomever@avma27.army.mil>
To: TACOMLCMC.DAForm2028@us.army.mil

Subject: DA Form 2028

1. From: Joe Smith
2. Unit: home
3. Address: 4300 Park
4. City: Hometown
5. St: MO
6. Zip: 77777
7. Date Sent: 19-OCT-93
8. Pub no: 55-2840-229-23
9. Pub Title: TM
10. Publication Date: 04-JUL-85
11. Change Number: 7
12. Submitter Rank: MSG
13. Submitter FName: Joe
14. Submitter MName: T
15. Submitter LName: Smith
16. Submitter Phone: 123-123-1234
17. Problem: 1
18. Page: 2
19. Paragraph: 3
20. Line: 4
21. NSN: 5
22. Reference: 6
23. Figure: 7
24. Table: 8
25. Item: 9
26. Total: 123
27. Text:

This is the text for the problem below line 27.

RECOMMENDED CHANGES TO PUBLICATIONS AND BLANK FORMS For use of this form, see AR 25-30; the proponent agency is ODISC4.						Use Part II (reverse) for Repair Parts and Special Tool Lists (RPSTL) and Supply Catalogs/Supply Manuals (SC/SM).	DATE 21 October 2003
TO: (Forward to proponent of publication or form) (Include ZIP Code) U.S. Army TACOM Life Cycle Management Command, ATTN: AMSTA-LCL-MPP / TECH PUBS 6501 E. 11 Mile Road, Warren, MI 48397-5000						FROM: (Activity and location) (Include ZIP Code) PFC JANE DOE Co A 3 RD Engineer Br. Ft Leonard Wood, MO 63108	
PART I – ALL PUBLICATIONS (EXCEPT RPSTL AND SC/SM) AND BLANK FORMS							
PUBLICATION/FORM NUMBER TM 10-1670-296-20&P						DATE 30 October 2002	TITLE Unit Manual for Ancillary Equipment for Low Velocity Air Drop Systems
ITEM NO.	PAGE NO.	PARA-GRAPH	LINE NO. *	FIGURE NO.	TABLE NO.	RECOMMENDED CHANGES AND REASON (Provide exact wording of recommended changes, if possible).	
	0036 00-2				1	<p><i>In Table 1, Sewing Machine Code Symbols, the second sewing machine code symbol should be MDZZ not MD22</i></p> <p><i>Change the manual to show Sewing Machine, Industrial: Zig-Zag; 308 stitch; medium-duty; NSN 3530-01-181-1421 as a MDZZ code symbol.</i></p>	
*Reference to line numbers within the paragraph or subparagraph.							
TYPED NAME, GRADE OR TITLE Jane Doe, PFC				TELEPHONE EXCHANGE/AUTOVON, PLUS EXTENSION (508) 233-4141 DSN 256-4141		SIGNATURE Jane Doe Jane Doe	

TO: (Forward direct to addressee listed in publication) U.S. Army TACOM Life Cycle Management Command, ATTN: AMSTA-LCL-MPP / TECH PUBS 6501 E. 11 Mile Road, Warren, MI 48397-5000					FROM: (Activity and location) (Include ZIP Code) PFC JANE DOE Co A 3 RD Engineer Br. Ft Leonard Wood, MO 63108			DATE 21 October 2003	
PART II – REPAIR PARTS AND SPECIAL TOOL LISTS AND SUPPLY CATALOGS/SUPPLY MANUALS									
PUBLICATION NUMBER TM 10-1670-296-20&P					DATE 30 October 2002		TITLE Unit Manual for Ancillary Equipment for Low Velocity Air Drop Systems		
PAGE NO.	COLM NO.	LINE NO.	NATIONAL STOCK NUMBER	REFERENCE NO.	FIGURE NO.	ITEM NO.	TOTAL NO. OF MAJOR ITEMS SUPPORTED	RECOMMENDED ACTION	
0066 00-					4			<i>Callout 16 in figure 4 is pointed to a <u>D-Ring</u>. In the Repair Part List key for Figure 4, item 16 is called a <u>Snap Hook</u>. Please correct one or the other.</i>	
PART III – REMARKS (Any general remarks or recommendations, or suggestions for improvement of publications and blank forms. Additional blank sheets may be used if more space is needed.)									
TYPED NAME, GRADE OR TITLE				TELEPHONE EXCHANGE/AUTOVON, PLUS EXTENSION			SIGNATURE		

RECOMMENDED CHANGES TO PUBLICATIONS AND BLANK FORMS For use of this form, see AR 25-30; the proponent agency is ODISC4.	Use Part II (reverse) for Repair Parts and Special Tool Lists (RPSTL) and Supply Catalogs/Supply Manuals (SC/SM).	DATE
---	---	------

TO: (Forward to proponent of publication or form) (Include ZIP Code) U.S. Army TACOM Life Cycle Management Command, ATTN: AMSTA-LCL-MPP / TECH PUBS 6501 E. 11 Mile Road, Warren, MI 48397-5000	FROM: (Activity and location) (Include ZIP Code)
---	---

PART I – ALL PUBLICATIONS (EXCEPT RPSTL AND SC/SM) AND BLANK FORMS

PUBLICATION/FORM NUMBER TM 10-8470-209-10	DATE 1 December 2013	TITLE Operator's Manual for Soldier Plate Carrier System
--	-------------------------	---

ITEM NO.	PAGE NO.	PARA-GRAPH	LINE NO. *	FIGURE NO.	TABLE NO.	RECOMMENDED CHANGES AND REASON (Provide exact wording of recommended changes, if possible).

**Reference to line numbers within the paragraph or subparagraph.*

TYPED NAME, GRADE OR TITLE	TELEPHONE EXCHANGE/AUTOVON, PLUS EXTENSION	SIGNATURE
----------------------------	--	-----------

TO: (Forward to proponent of publication or form) (Include ZIP Code) U.S. Army TACOM Life Cycle Management Command, ATTN: AMSTA-LCL-MPP / TECH PUBS 6501 E. 11 Mile Road, Warren, MI 48397-5000	FROM: (Activity and location) (Include ZIP Code)	DATE
---	--	-------------

PART II – REPAIR PARTS AND SPECIAL TOOL LISTS AND SUPPLY CATALOGS/SUPPLY MANUALS

PUBLICATION NUMBER TM 10-8470-209-10					DATE 1 December 2013		TITLE Operator's Manual for Soldier Plate Carrier System	
PAGE NO.	COLM NO.	LINE NO.	NSN	REF NO.	FIGURE NO.	ITEM NO.	TOTAL NO. OF MAJOR ITEMS SUPPORTED	RECOMMENDED ACTION
Empty table body for Part II								

PART III – REMARKS (Any general remarks or recommendations, or suggestions for improvement of publications and blank forms. Additional blank sheets may be used if more space is needed.)

Large empty space for Part III remarks		
--	--	--

TYPED NAME, GRADE OR TITLE	TELEPHONE EXCHANGE/AUTOVON, PLUS EXTENSION	SIGNATURE
----------------------------	---	-----------

RECOMMENDED CHANGES TO PUBLICATIONS AND BLANK FORMS For use of this form, see AR 25-30; the proponent agency is ODISC4.	Use Part II (reverse) for Repair Parts and Special Tool Lists (RPSTL) and Supply Catalogs/Supply Manuals (SC/SM).	DATE
---	---	------

TO: (Forward to proponent of publication or form) (Include ZIP Code) U.S. Army TACOM Life Cycle Management Command, ATTN: AMSTA-LCL-MPP / TECH PUBS 6501 E. 11 Mile Road, Warren, MI 48397-5000	FROM: (Activity and location) (Include ZIP Code)
---	---

PART I – ALL PUBLICATIONS (EXCEPT RPSTL AND SC/SM) AND BLANK FORMS

PUBLICATION/FORM NUMBER TM 10-8470-209-10	DATE 1 December 2013	TITLE Operator's Manual for Soldier Plate Carrier System
--	-------------------------	---

ITEM NO.	PAGE NO.	PARA-GRAPH	LINE NO. *	FIGURE NO.	TABLE NO.	RECOMMENDED CHANGES AND REASON (Provide exact wording of recommended changes, if possible).

**Reference to line numbers within the paragraph or subparagraph.*

TYPED NAME, GRADE OR TITLE	TELEPHONE EXCHANGE/AUTOVON, PLUS EXTENSION	SIGNATURE
----------------------------	--	-----------

TO: <i>(Forward to proponent of publication or form)</i> <i>(Include ZIP Code)</i> U.S. Army TACOM Life Cycle Management Command, ATTN: AMSTA-LCL-MPP / TECH PUBS 6501 E. 11 Mile Road, Warren, MI 48397-5000	FROM: <i>(Activity and location)</i> <i>(Include ZIP Code)</i>	DATE
---	---	-------------

PART II – REPAIR PARTS AND SPECIAL TOOL LISTS AND SUPPLY CATALOGS/SUPPLY MANUALS

PUBLICATION NUMBER TM 10-8470-209-10					DATE 1 December 2013		TITLE Operator's Manual for Soldier Plate Carrier System	
PAGE NO.	COLM NO.	LINE NO.	NSN	REF NO.	FIGURE NO.	ITEM NO.	TOTAL NO. OF MAJOR ITEMS SUPPORTED	RECOMMENDED ACTION

PART III – REMARKS *(Any general remarks or recommendations, or suggestions for improvement of publications and blank forms. Additional blank sheets may be used if more space is needed.)*

TYPED NAME, GRADE OR TITLE	TELEPHONE EXCHANGE/AUTOVON, PLUS EXTENSION	SIGNATURE
----------------------------	--	-----------

RECOMMENDED CHANGES TO PUBLICATIONS AND BLANK FORMS For use of this form, see AR 25-30; the proponent agency is ODISC4.	Use Part II (reverse) for Repair Parts and Special Tool Lists (RPSTL) and Supply Catalogs/Supply Manuals (SC/SM).	DATE
---	---	------

TO: (Forward to proponent of publication or form) (Include ZIP Code) U.S. Army TACOM Life Cycle Management Command, ATTN: AMSTA-LCL-MPP / TECH PUBS 6501 E. 11 Mile Road, Warren, MI 48397-5000	FROM: (Activity and location) (Include ZIP Code)
---	---

PART I – ALL PUBLICATIONS (EXCEPT RPSTL AND SC/SM) AND BLANK FORMS

PUBLICATION/FORM NUMBER TM 10-8470-209-10	DATE 1 December 2013	TITLE Operator's Manual for Soldier Plate Carrier System
--	-------------------------	---

ITEM NO.	PAGE NO.	PARA-GRAPH	LINE NO. *	FIGURE NO.	TABLE NO.	RECOMMENDED CHANGES AND REASON (Provide exact wording of recommended changes, if possible).

**Reference to line numbers within the paragraph or subparagraph.*

TYPED NAME, GRADE OR TITLE	TELEPHONE EXCHANGE/AUTOVON, PLUS EXTENSION	SIGNATURE
----------------------------	--	-----------

TO: (Forward to proponent of publication or form) (Include ZIP Code) U.S. Army TACOM Life Cycle Management Command, ATTN: AMSTA-LCL-MPP / TECH PUBS 6501 E. 11 Mile Road, Warren, MI 48397-5000	FROM: (Activity and location) (Include ZIP Code)	DATE
---	--	-------------

PART II – REPAIR PARTS AND SPECIAL TOOL LISTS AND SUPPLY CATALOGS/SUPPLY MANUALS

PUBLICATION NUMBER TM 10-8470-209-10					DATE 1 December 2013		TITLE Operator's Manual for Soldier Plate Carrier System	
PAGE NO.	COLM NO.	LINE NO.	NSN	REF NO.	FIGURE NO.	ITEM NO.	TOTAL NO. OF MAJOR ITEMS SUPPORTED	RECOMMENDED ACTION

PART III – REMARKS (Any general remarks or recommendations, or suggestions for improvement of publications and blank forms. Additional blank sheets may be used if more space is needed.)

TYPED NAME, GRADE OR TITLE	TELEPHONE EXCHANGE/AUTOVON, PLUS EXTENSION	SIGNATURE
----------------------------	---	-----------

By Order of the Secretary of the Army:

RAYMOND T. ODIERNO
General, United States Army
Chief of Staff

Official:

A handwritten signature in black ink, appearing to read "Gerald B. O'Keefe". The signature is written in a cursive style with a large initial "G" and "O".

GERALD B. O'KEEFE
Administrative Assistant to the
Secretary of the Army
1328408

DISTRIBUTION:

Initially published in electronic media only. When funds become available, this publication will be distributed in accordance with the initial distribution number (IDN) 258026, requirements for TM 10-8470-209-10.

The Metric System and Equivalents

Linear Measure

1 centimeter = 10 millimeters = .39 inch
 1 decimeter = 10 centimeters = 3.94 inches
 1 meter = 10 decimeters = 39.37 inches
 1 dekameter = 10 meters = 32.8 feet
 1 hectometer = 10 dekameters = 328.08 feet
 1 kilometer = 10 hectometers = 3,280.8 feet

Weights

1 centigram = 10 milligrams = .15 grain
 1 decigram = 10 centigrams = 1.54 grains
 1 gram = 10 decigrams = .035 ounce
 1 dekagram = 10 grams = .35 ounce
 1 hectogram = 10 dekagrams = 3.52 ounces
 1 kilogram = 10 hectograms = 2.2 pounds
 1 quintal = 100 kilograms = 220.46 pounds
 1 metric ton = 10 quintals = 1.1 short tons

Liquid Measure

1 centiliter = 10 milliliters = .34 fl. ounce
 1 deciliter = 10 centiliters = 3.38 fl. ounces
 1 liter = 10 deciliters = 33.81 fl. ounces
 1 dekaliter = 10 liters = 2.64 gallons
 1 hectoliter = 10 dekaliters = 26.42 gallons
 1 kiloliter = 10 hectoliters = 264.18 gallons

Square Measure

1 sq. centimeter = 100 sq. millimeters = .15 sq. inch
 1 sq. decimeter = 100 sq. centimeters = 15.5 sq. inches
 1 sq. meter (centare) = 100 sq. decimeters = 10.76 sq. feet
 1 sq. dekameter (are) = 100 sq. meters = 1,076.4 sq. feet
 1 sq. hectometer (hectare) = 100 sq. dekameters = 2.47 acres
 1 sq. kilometer = 100 sq. hectometers = .386 sq. mile

Cubic Measure

1 cu. centimeter = 1000 cu. millimeters = .06 cu. inch
 1 cu. decimeter = 1000 cu. centimeters = 61.02 cu. inches
 1 cu. meter = 1000 cu. decimeters = 35.31 feet

Approximate Conversion Factors

<i>To change</i>	<i>To</i>	<i>Multiply by</i>	<i>To change</i>	<i>To</i>	<i>Multiply by</i>
inches	centimeters	2.540	ounce-inches	newton-meters	.007062
feet	meters	.305	centimeters	inches	.394
yards	meters	.914	meters	feet	3.280
miles	kilometers	1.609	meters	yards	1.094
square inches	square centimeters	6.451	kilometers	miles	.621
square feet	square meters	.093	square centimeters	square inches	.155
square yards	square meters	.836	square meters	square feet	10.764
square miles	square kilometers	2.590	square meters	square yards	1.196
acres	square hectometers	.405	square kilometers	square miles	.386
cubic feet	cubic meters	.028	square hectometers	acres	2.471
cubic yards	cubic meters	.765	cubic meters	cubic feet	35.315
fluid ounces	milliliters	29.573	cubic meters	cubic yards	1.308
pints	liters	.473	milliliters	fluid ounces	.034
quarts	liters	.946	liters	pints	2.113
gallons	liters	3.785	liters	quarts	1.057
ounces	grams	28.349	liters	gallons	.264
pounds	kilograms	.454	grams	ounces	.035
short tons	metric tons	.907	kilograms	pounds	2.205
pound-feet	newton-meters	1.356	metric tons	short tons	1.102
pound-inches	newton-meters	.11296			

Temperature (Exact)

°F	Fahrenheit	5/9 (after	Celsius	°C
	temperature	subtracting 32)	temperature	

PIN: 087560-000