

**PURCHASE DESCRIPTION RUGGED ALL TERRAIN
(RAT) BOOT, TEMPERATE WEATHER, MARINE CORPS**

1. SCOPE

1.1 Scope. This purchase description covers the requirements for the U.S. Marine Corps Rugged All Terrain (RAT) Boot Temperate Weather. This item is intended for wear by all Marines while in garrison and while conducting combat operations. This document covers the requirements for an Olive Mohave color number 200512 colored USMC Temperate Weather Boot for use in both wet and dry environments from 20 to 60 degrees F (-6 to 15 degrees C). Unless otherwise indicated, all performance requirements called out in this specification pertain to an item made on a size 10R men's last.

1.2 Classification. The boots shall be in the following classes and sizes.

Classes

Class I – US Cattlehide Nubuck upper leather

Schedule of Sizes

The boots for men shall be in the following whole and half sizes: 3 through 15 inclusive, and whole size 16, in the following widths: N, R, W, XW, (B, D, EE, EEEE). The boots for women shall be in the following whole and half sizes: 5 through 9 inclusive, and whole sizes: 4, 10, and 11, in widths of R, W (D, EE), and in size 4.5R. Women's sizes will contain an "F" to differentiate them from the men's boot (ex. Men's: 10R, Women's: 8RF). See paragraph 6.2.

Beneficial comments (recommendations, additions, deletions) and any pertinent data which may be of use in improving this document should be addressed to: Defense Logistics Agency – Troop Support, Clothing and Textiles Directorate, Attn: DLA Troop Support-CRFD, Bldg. 6D, 700 Robbins Avenue, Philadelphia, PA 19111-5096, by using the Standardization Document Improvement Proposal (DD Form 1426), or by letter.

AMSC N/A

FSC 8430

FSC 8435

DISTRIBUTION STATEMENT A. Approved for public release; distribution is unlimited.

2. APPLICABLE DOCUMENTS

2.1 General. The documents listed in this section are specified in Sections 3, 4, or 5 of this specification. This section does not include documents cited in other sections of this specification or recommended for additional information or as examples. While every effort has been made to ensure the completeness of this list, document users are cautioned that they must meet all specified requirements documents cited in sections 3, 4, or 5 of this specification, whether or not they are listed.

2.2 Government documents.

2.2.1 Specifications, standards, and handbooks. The following specifications, standards, and handbooks form a part of this document to the extent specified herein. Unless otherwise specified, the issues of these documents are those cited in the solicitation or contract (see 6.2).

SPECIFICATIONS

COMMERCIAL ITEM DESCRIPTIONS

A-A- 55093 - Laces, Nylon

MILITARY

MIL-PRF-3122J -Leather, Cattlehide, for Footwear for Uppers and Gussets, Chrome Tanned, Fatliquored

DRAWINGS

DEFENSE LOGISTICS AGENCY – TROOP SUPPORT

2-1-1635 -Speed Lace Assembly

(Copies of drawings are available from the Defense Supply Center-Philadelphia, 700 Robbins Avenue, Philadelphia, PA 19111-5096, Attn: DLA Troop Support-CRFD-TDR.)

2.2.2 Other Government documents, drawings, and publications. The following other Government documents drawings and publications form a part of this document to the extent specified herein. Unless otherwise specified, the issues shall be those cited in the solicitation or contract.

FEDERAL TRADE COMMISSION

RULES AND REGULATIONS UNDER THE TEXTILE FIBER PRODUCTS IDENTIFICATION ACT

(Copies may be obtained without charge from the Federal Trade Commission, Washington, DC 20580-0001.)

2.3 Non-Government publications. The following documents form a part of this document to the extent specified herein. Unless otherwise specified, the issues of the documents are those cited in the solicitation or contract (see 6.2).

TECHNICAL MANUAL OF THE AMERICAN ASSOCIATION OF TEXTILE CHEMISTS AND COLORISTS

AATCC Evaluation Procedure 1, Gray Scale for Color Change
AATCC Evaluation Procedure 2, Gray Scale for Staining
AATCC Evaluation Procedure 8, AATCC 9-Step Chromatic Transference Scale

AATCC Evaluation Procedure 9, Visual Assessment of Color Difference of Textiles
AATCC 119 - Color Change due to Flat Abrasion (Frosting): Screen
AATCC 127 - Water Resistance: Hydrostatic Pressure Test
AATCC 22 - Water Repellency: Spray Test

(Applications for copies should be addressed to the AATCC National Headquarters, P.O. Box 12215, Research Triangle Park, NC 27709-2215.)

AMERICAN SOCIETY FOR TESTING AND MATERIALS (ASTM)

- ASTM-D-297 - Rubber Products-Chemical Analysis
- ASTM-D-412 - Vulcanized Rubber and Thermoplastic Elastomers (Tension Elongation)
- ASTM-D-471 - Rubber Property-Effect of Liquids
- ASTM-D-624 - Tear Strength of Conventional Vulcanized Rubber and Thermoplastic Elastomers
- ASTM-D-751 - Coated Fabrics (Hydrostatic Resistance or Breaking Strength)
- ASTM-D-792 - Density and Specific Gravity (Relative Density) of Plastics by Displacement
- ASTM-D-816 - Rubber Cements
- ASTM-D-1052 - Measuring Rubber Deterioration-Cut Growth Using Ross Flexing Apparatus
- ASTM-D-1055 - Specifications for Flexible Cellular Materials-Latex Foam
- ASTM-D-1630 - Rubber Property-Abrasion Resistance (Footwear Abrader)
- ASTM-D-1683 - Standard Test Method for Failure in Sewn Seams of Woven Apparel Fabrics
- ASTM-D-1777 - Thickness of Textile Materials
- ASTM-D-1974 - Standard Practice for Methods of Closing, Sealing, and Reinforcing Fiberboard Boxes
- ASTM-D-2208 - Breaking Force and Elongation, Grab Method
- ASTM-D-2240 - Rubber Property-Durometer Hardness
- ASTM-D-3273 - Resistance to Growth of Mold
- ASTM-D-3574 - Flexible Cellular Materials- Slab, Bonded, and Molded Urethane Foams
- ASTM-D-3575 - Compression Set of Cushion Materials
- ASTM-D-3787 - Bursting Strength of Textiles Constant-Rate-of-Traverse (CRT) Ball Burst Test
- ASTM-D-3886 - Abrasion Resistance for Textile Fabrics (Inflated Diaphragm Apparatus)
- ASTM-D-4786 - Stitch Tear Strength, Single Hole
- ASTM-D-4966 - Abrasion Resistance of Textile Fabrics (Martindale Abrasion Tester Method)
- ASTM-D-5118 - Standard Practice for Fabrication of Fiberboard Shipping Boxes
- ASTM-E-18 - Rockwell Hardness and Rockwell Superficial Hardness of Metallic Materials
- ASTM-E-96 - Water Vapor Transmission of Materials
- ASTM-F-392 - Flex Durability of Flexible Barrier Materials
- ASTM-F-1614 - Shock Attenuating Properties of Material Systems for Athletic Footwear

(Copies of documents are available on line at www.astm.org or from the ASTM International, 100 Barr Harbor Drive, West Conshohocken, PA 19426-2959.)

AMERICAN SOCIETY FOR QUALITY

ANSI/ASQC Z1.4 - Sampling Procedures and Tables for Inspection by Attributes

(Applications for copies should be addressed to the American Society for Quality Control, P.O. Box 3005, 611 East Wisconsin Avenue, Milwaukee, WI 53201-4606.)

PI T451cm-84 - Clark Stiffness

(Applications for copies should be addressed to the Technical Association of the Pulp and Paper Industry (TAPPI), P.O. Box 105113, Atlanta, GA 30348.)

SATRA FOOTWEAR TECHNOLOGY MILITARY TEST METHODS (MTM)

TM-2	- Tensile Strength of Fiberboards and Sheet Insole Materials
TM-3	- Flexing Endurance Test for Fiberboards
TM-14	- Resistance to Scuffing by Mild Circular Abrasion of Fiberboards
TM-31	- Abrasion Resistance-Martindale Method
TM-33	- Seam Fray
TM-64	- Compression Set
TM-77	- Flexing Machine- Water Penetration Test
TM-80	- Transverse or Z Direction Tensile Strength of Sheet Materials
TM-98	- Dimensional Stability with Changes in Atmospheric Humidity
TM-101	- Surface Peel Strength of Insole Materials
TM-223	- Non marking (rubber outsole)
TM-363	- Whole Shoe Flexing Machine (Special – High Water Level)
TM-404	- Rapid Sole Adhesion Test: For Complete Footwear
TM-405	- Determination of Shear and Peel of Insole Ribs
TM-31	- Abrasion Resistance
TM-83	- Measurement of the Area Shape Retention and Collapsing Load of Formed Toe Puff and Stiffener Materials

(Applications for copies of SATRA Test Methods should be addressed to: SATRA Technology Center, SATRA House; Rockingham Road, Kettering, Northamptonshire; NN 16 9 JH, England.)

(Non-Government standards and other publications are normally available from the organizations that prepare or distribute the documents. These documents also may be available in or through libraries or other informational services.)

2.4 Order of precedence. Unless otherwise noted herein or in the contract, in the event of a conflict between the text of this document and the references cited herein, the text of this document takes

precedence. Nothing in this document, however, supersedes applicable laws and regulations unless a specific exemption has been obtained.

3. REQUIREMENTS

3.1 First article. When specified (see paragraph 6.2) samples shall be subjected to first article inspection (see paragraph 6.3).

3.2 Recycled, recovered, or environmentally preferable materials. Recycled, recovered, or environmentally preferable materials should be used to the maximum extent possible provided that the material meets or exceeds the operational and maintenance requirements, and promotes economically advantageous life cycle costs.

3.3 Design. The boot shall be Olive Mohave color number 200512 in color. It shall have a padded comfort leather collar, a partial speed lace closure system (lace-to-toe design) with a flex “V” notch, and removable cushion inserts. The upper leather shall be Class I US Cattlehide Nubuck, breathable, water-resistant, mildew resistant and be Olive Hot Pocket Nubuck 492006. All materials on the exterior of the boot and visible to the wearer shall be subdued in color and match the color of the leather. The boot shall have nylon quarters, PTFE microporous liner, lining, comfort collar, backstay, ankle reinforcement, resolable rubber outsole and a polyether polyurethane cushion midsole. The design must incorporate fabrics to insure the boot is waterproof at all times. The exterior components, including the comfort collar, backstay, ankle reinforcement straps, shall not wick moisture. The USMC RAT Temperate Weather Boot shall be manufactured using only a stitchdown process and shall be capable of being resoled at any certified cobbler through its lifecycle, given that the upper is in good condition. Materials used in the production of this item shall be of standard commercial practice, and shall be modified if necessary in order to meet the needs of Marines in the environment for which the item is intended. Materials used to produce this item shall not promote fungal/bacterial infestation, reduce foot odor, and be non-hazardous to the user. These traits in the chosen materials shall be permanent. The quality and workmanship of the item is expected to exceed that found in the commercial market, given the environment for which the item is intended. It is expected that all materials used to meet the Purchase Description will hold up under the extreme conditions found in Field and Garrison temperate environments, combat operations for the jungle, desert, and mountains. Materials should be selected to optimize the overall boot performance for the given environment, not specifically address a single measure of performance (i.e., weight, comfort, shock attenuation, water absorption, etc). The design and pattern must follow the example provided in Figures 2A and 2B.

The RAT Temperate Weather Boot will have the following attributes:

- The RAT Temperate Weather Boot shall perform well in hot and temperate weather environments for 2 years (T), 5 years (O).
- The RAT boot shall weigh 2.2 pounds (T), less than 1 pound (O).
- The RAT boot shall have a Olive Mohave color and be non-reflective (T=O).
- The RAT boot shall be made of chemically resistant materials that are non-corrosive (T=O)
- The surface coverage of the RAT boot shall support a combat loaded Marine weighing 355lbs (T), a combat loaded Marine weighing 400 lbs (O).
- The RAT boot shall be made of moisture wicking and non-absorbent waterproof materials (T=O).

RAT PD 13-01

- The RAT boot shall fit the 5th through the 95th percentile Marine (T=O).
- The RAT boot shall be made IAW US military, DoD, and US commercial clothing and textile standards approved by the Marine Corps.

In addition to above listed attributes, the RAT Temperate Weather Boot shall meet all requirements within the salient characteristics provided below.

- Lace to toe pattern
- Stitch-down construction with lockstitch embedded in 5 iron composition mid sole
- ¼ inch welt lip throughout the entire out sole of the boot.
- Double Stitch at toe: through midsole and outsole
- 1000 denier nylon
- 5-5 5oz water proof nubuck leather
- impregnated leather, split leather to rand and heel counter
- Thermal plastic counter
- Thermal plastic toe box
- Fiberglass shank
- 5 iron composition mid sole (stitch down construction)
- PU mid sole
- Vibram Fire and Ice outsole
- Solid brass eyelets
- 72: color match lace
- UPACO brand adhesive
- Thread shall be Coats (Brand Name or Equal) T99 weight nylon with T92 for the bobbin for the upper stitching and waxed Coats (Brand Name or Equal) T693 weight for bottom stitching with T554 waxed bobbin
- Upper Quarter Panels

3.3.1 Weight. The weight of the entire end product shall not exceed 2.2 lbs (dry) for a size 10R boot made on a size 10R last, footbed included. The weight of the boot when saturated with water shall be minimized through materials and construction technique. Materials selected to accomplish this end item weight must meet durability requirements of the US Marine Corps. Materials that trade weight for durability or overall performance are not in the best interest of the US Marine Corps.

3.3.2 Height. The height of the boot shall be between 8.5 and 9.0 inches from the feather line to the top of the boot at its tallest point, so that users are protected from the elements and provided with biomechanical support. The height shall be graded up and down between sizes and widths appropriately to minimize the interference with the calf musculature. The overall height of the boot shall include the comfort collar. Height shall not vary between boots of a pair by more than ¼ (0.25) inch.

3.3.3 Shock Attenuation. Shock Attenuation shall be optimized for user comfort and injury reduction. Peak Acceleration (Peak g) shall not exceed 18.00g in the Forefoot or 14.00g in the rear foot. Shock attenuation shall be achieved through the choice of standard materials and construction techniques used in commercial industry and found in this Purchase Description. Human biomechanical gait parameters while wearing combat boots shall not be compromised to achieve increased shock attenuation. Requirements for shock attenuation shall be tested on the end item as specified in Table XVI.

3.3.4 Forefoot Flexibility. Longitudinal forefoot flexibility shall be optimized such that normal gait patterns are minimally disturbed, and risk of increased injury is minimized. Torsional flexibility shall be optimized to allow normal range of motion and mediolateral stability during gait (loaded and unloaded), and prevent overpronation.

3.3.5 Bond Strength. The bond achieved between any of the bottoming layers (cushion midsole to upper, solid midsole, and cushion midsole to outsole) to include the boot upper shall meet performance requirements as stated below and be permanently resistant to any delamination. Any bond failures between any of the components will be explicitly covered under warranty, and those failed items will be replaced on a one-for-one basis, no questions asked (as is done in commercial practices).

3.3.5.1 Solid midsole to the upper. (For Stitchdown Construction Only) The bond strength (at the heel) shall not be less than 700 lbs. The test shall be performed on the end item as specified in Table XVI. When 5 end items are tested, no more than one test item may fall below 650 lbs, while no recorded values shall fall below 600 lbs. If test results find values to be less than specified due to material failure in regard to the bond between the layers, the test will be classified as a failure. Testing shall be as specified in 4.10.3.

3.3.5.2 Outsole to Cushion Midsole Bond Strength. The outsole to cushion midsole strength shall not be less than 140 pounds when tested as specified in Table XVI. The test shall be performed on the end item. When 5 end items are tested, no more than one test item may fall below 140 lbf. For the full length of the pull, no recorded value shall fail below 100 lbf. Testing shall be as specified in 4.10.4.

3.3.5.3 Solid midsole to cushion midsole bond strength. The solid rubber midsole or base sole to cushion midsole bond strength shall not be less than 120 pounds when tested as specified in Table XVI. The test shall be performed on the end item. When 5 end items are tested, no more than one test item may fall below 120 lbf for the entire length of the pull test while no recorded values shall fall below the 100 lbf. Testing shall be as specified in 4.10.4.

3.3.6 Water Absorption and Drying. Materials selected for use in this item shall be such that water absorption (and thus weight gain) is minimized, and time to completely dry, once saturated, is minimized. Materials selected to accomplish this end item performance must meet field durability requirements of the US Marine Corps. Materials that trade water absorption and drying time for durability or overall performance are not in the best interest of the US Marine Corps.

3.3.7 Whole boot Moisture Vapor Transmission Rate (MVTR). The whole boot breathability shall not be less than 3.0 grams/hour when tested as specified in Table XVI and paragraph 4.10.2.

3.3.8 Temperature, Environment, and Material Weathering. Materials selected for use in this item shall perform equally well in field environment for the life of the item. Temperature ranges that can be expected for this item are 25 degrees F - 60 degrees F. Humidity ranges that can be expected for this item are 0% - 100%. Exposure to UVA / UVB wavelengths shall not interfere with the material performance or color of the item/component. Immersion in salt water shall minimally affect end

item/ component performance. Items will be expected to optimally perform with consistent exposure to the above conditions.

3.3.9 Visual shade matching (components). All components referencing matching the standard shade and appearance shall be a good match to the standard sample under horizon lamplight at 2300 ± 200 K when tested as specified in paragraph 4.5.

3.3.10 Leakage. The finished boots shall show no evidence of leakage when tested as specified in paragraph 4.10.1.

3.3.11 Field Life /Shelf Life. Shelf life for the USMC RAT Temperate Weather Boot shall be no less than 5 years when stored for future use by the U.S. Military. Field life shall be no less than 24 months under normal conditions by Marines in the Jungle, Desert, Mountainous, or Garrison environments.

3.4 Materials.

3.4.1 Leather. The leather shall be grain out nubuck, drum dyed USMC Olive Hot Pocket Nubuck 492006, with color penetrating throughout the thickness of the hide so that the chrome tannage is not visible. The leather shall be breathable, waterproof, mildew resistant. The thickness shall be as specified for the cut parts in Table IX. Skiving of leather parts will be permitted.

3.4.1.1 Upper Leather. Shall conform to MIL-PRF-3122J, Type I, Treatment A and Treatment B, with the following exceptions:

- a. The grain surface shall be lightly buffed removing the surface of the grain only, for a nubuck appearance with a fine uniform nap.
- b. The surface color shall be antiqued to provide a muted camouflage effect and shall match Olive Hot Pocket Nubuck 492006.
- c. The finish requirements for the leather shall not apply.
- d. The tear strength requirements for the front edge stays and eyelet stays shall not apply.
- e. As an option, the eyelet stays may conform to MIL-PRF-3122J, Type II, Treatment A.

3.4.1.2 Gusset Leather. Shall conform to MIL-PRF-3122J, Type II, Treatment A, and match the upper leather appearance. As an option, the gusset leather may conform to MIL-PRF-3122J, Type I, Treatment A and Treatment B.

3.4.1.3 Impregnated Leather. Within the toe box area and the heel area of the boot, there will be an additional piece of leather (as seen in Fig 2A and 2B) for additional abrasion resistance protection. The color shall match USMC Olive Mohave color number 200512. The leather will be injected with polyurethane. This will be a double vamp construction.

3.4.2 Quarter Panels. The quarter side panels shall be 100% nylon 6.6 or equal; 2x2 basket weave 140 filaments per inch of 1000-denier nylon in both warp and filling direction, weighing 13.7 (+/- 1.3) oz/sq yd. and conforming to the standard shade of Olive Mohave color number 200512. The material shall be fungal resistant, water resistant, non-wicking, and backed with a polytetrafluorethylene, microporous

membrane. The two-layer material shall conform to the physical requirements listed in Table I when tested as specified in paragraph 4.9. Tear strength of the material shall be such that normal Marine use and wear does not cause undue damage to the quarter panels. Construction of the end item shall be such that the seam strength between the 1000-denier nylon and all other components (i.e. backstrap, ankle support straps, and binding tape) is adequate for the life of the item. The top of backstay shall be folded over the quarter side panels, stitched and shall have a clean, finished appearance. The stitching shall be durable and extend the life of the item. A minimum of two rows of stitching are required around the eyelet stay wedge and ankle area for increased support in accordance with Figures 2A and 2B.

Table I. Quarter Panel Requirements

Component	Characteristic	Requirement
Quarter Panels	MVTR (breathability)	80% not less than 500 gm/m ² /24hrs.
	Water Repellency	90 (IS04)

3.4.3 **Boot Lining**. The three-layer lining shall consist of Gore-Tex (Brand Name or Equal) Olive 3-bar knit textile face fabric with PTFE backing to provide comfort. The lining shall manage moisture, minimize water absorption, and dry quickly. The color shall be Olive Mohave color number 200512 to approximate the exterior color of the USMC Temperate Weather RAT Boot. The combined material shall provide a minimum moisture vapor permeability of 640 grams per square meter per 24 hours when tested as specified in paragraph 4.9. The combined material shall have abrasion characteristics capable of meeting the needs of field Marines in the environment for which it is intended, and have a hand suitable for the comfort of the wearer for the life of the item. The lining shall be properly mated with the upper and shall not be loose, wrinkled, or discolored. The lining shall be permanently attached to the top of the insole board for the life of the item. Lining shall be made using single-seam “round-the-world” construction. The bootie stitch shall be sealed/finished using 7/8” polytetrafluorethylene seam sealing tape.

3.4.3.1 **Three-layer laminate**. The three-layer laminate lining shall consist of a Gore-Tex (Brand Name or Equal) Olive 3-bar knit textile face (specify ASTM 4966), a waterproof film, and a tricot knit cloth. The package shall conform to the requirements in paragraphs 3.4.3.1.1, 3.4.3.1.2, 3.4.3.1.3, and 3.4.3.1.4. The textile face shall be laminated to one side of the waterproof film and the tricot knit cloth shall be laminated to the other side of the waterproof film. The face side of the laminate cloth shall be the side with the single layer package. The three-layer laminate shall conform to the requirements specified in Table II, when tested as specified in paragraph 4.9. Lining shall extend to the top of the collar and top of the tongue.

3.4.3.1.1 **Face layer**. The package shall consist of a textile face that meets the Martindale Abrasion and Burst Strength performance criteria listed in Table II when tested as specified in paragraph 4.9. The color of the Face Layer fabric will be approximate Olive Mohave color number 200512 colored herringbone, or equal based on government approval.

3.4.3.1.2 **Waterproof film**. The waterproof film shall be polytetrafluorethylene, micro porous.

3.4.3.1.3 Tricot knit. The tricot knit cloth shall be nylon weighing a minimum of 1.0 oz/yd² and meet the requirements in Table II when tested as part of the three-layer laminate lining as specified in paragraph 4.9. The color shall be natural.

Table II. Laminated Cloth Performance Requirements

Characteristics	Requirements
Martindale Abrasion	
Fabric Only; Dry	153,600 revs/ 9,600 cycles (min)
Bursting Strength	
Fabric Only	125 (min)
Hydrostatic Resistance (psi)	
Liner cloth (initial)	50 (min)
At Seam	50 (min)
After Synthetic Perspiration	50 (min)
After Diesel Fuel Oil	50 (min)
Water Permeability/ Resistance	
Liner cloth (initial)	No leakage
At Seam	No leakage
After Synthetic Perspiration	No leakage
After Diesel Fuel Oil	No leakage
Abrasive Durability (cycles to leak)	
Back / Leather Side	600 cycles, No leakage
Moisture Vapor Transmission Rate (g/m ² /24hrs)	
B method	640 (min)
BW method	4,000 (min)
Flex Durability	
Gelbo (cycles to leak)	3,000 cycles, No leakage
Wet (hrs to leak)	24 (hrs)

3.4.4 Binding Tape. Binding Tape shall be used on all exposed edges of the 1000-denier nylon. The color shall be Olive Mohave color number 200512 matching that of the standard sample. The binding tape shall be bound to the nylon fabric for the life of the item, and not affect the Marine's comfort or the overall item performance. The material shall be treated to eliminate moisture wicking.

3.4.5 Removable cushion insert. The removable cushion insert shall be a low-density polyether-polyurethane heel cup support made of a polyurethane system, black in color, and lined (black or tan in color). The cloth shall conform to the requirements of the cushioned insert in Table III when tested as specified in paragraph 4.9. The cushioned insert shall provide comfort, and shall be made to optimize the fit of the item, given the last the item was made on. The cushion insert should take a minimal

compression set, even after extensive wear or material conditioning. The cushion insert and its lining shall be resistant to fungal growth, provide good frictional characteristics, and shall not be susceptible to hydrolysis. Cushion inserts shall have durability such that they last for the life of the item. Cushion inserts shall be properly mated to the item with a last used in the manufacturing of the item. Cushion inserts shall be mated, by size, to the correct sizes boots and shall be uniform. The total thickness of the insert shall be a minimum of 0.100 inch forward of the instep, and a minimum of 0.220 inch elsewhere.

Table III. Removable Cushion Insert Requirements

Characteristics	Physical Requirements
Density	16-20 lb/cu.ft
Foam Hardness	50-65 Shore 00
Tensile strength	82 lb./sq. in. (min)
Compression set	25% @ 10.6 psi
@ 77 degrees F	50% @ 21.6 psi
Fabric Liner: Martindale Abrasion	
Fabric Only; Dry	153,600 revs/9,600 cycles (min)
Fabric Liner: Bursting Strength	
Fabric Only	125 lbs. min.

3.4.6 Comfort Collar. The top band shall have a length equal to the circumference of the boot top exclusive of the gusset and tongue, and shall provide the necessary padding for comfort. The band width should be of an equal height of 5/8 inches +/-1/8 inch around the top of the boot as presented in figures 2A and 2B. Based on a size 10R, collar top line shall measure 10.0 inches +/-1/8 inch in length.

3.4.7 Box Toe. A thermoplastic box toe shall be used and shall conform to the performance requirements of Table IV. Testing shall be as specified in paragraph 4.9. The box toes shall be skived 3/8 ± 1/8 inch wide at the breast. The box toe shall be located between the lining and the vamp leather.

Table IV. Thermoplastic Performance Requirements

Characteristics	Physical Requirements
Initial Collapsing Load (N)	>130 N
Resilience (%) <u>1/</u>	25% min
Moisture Resistance (%) <u>2/</u>	80% min
Area Shape Retention (%)	
Initial	85% min
10 th collapse	60% min

1/ Resilience is percentage retention of initial collapsing load after ten collapses.

2/ Moisture resistance is percentage retention of initial dry collapsing load after 1 hour immersion.

3.4.8 Heel Counters. A thermoplastic counter shall be used and shall conform to the performance requirements of Table IV when tested as specified in paragraph 4.9. The total thickness shall be 0.090 ± 0.005 inches. The heel counter shall be stitched through to the midsole.

3.4.9 Shank. The fiberglass shanks, shall be bonded to the insole, and shall conform to the shape of the last and graded proportionally. The fiberglass shank (glass and resin area) when cured shall be $3/4 \pm 1/16$ inch in width.

3.4.10 Eyelets and Speed Lace Assembly. The eyelets and speed laces shall be stamped brass with an Olive Mohave color number 200512 coated finish, which is durable enough to remain on the eyelets and speed laces for the life of the item. The eyelets and speed laces shall not rust, tarnish, or otherwise change the subdued finish color for the life of the item. Eyelet and Speedlace attachment shall be such that they remain permanently fixed to the upper through the life of the item. Adjustments shall be made such that all sizes allow users to easily utilize the speed lace system, and proper closure of the item is achieved. Speed laces and eyelets shall be equally spaced on the eyelet stays to allow proper lacing and cinching of the boot for donning and doffing, and shall have the same alignment between both rows. The bottom eyelets shall be placed in a position on the foot such that they do not cause hot spots, blisters, or other irritation.

3.4.11 Bottoming. The bond achieved between the boot upper, solid midsole, cushion midsole, and outsole shall be resistant to any delamination for the life of the item. Bottoming shall be optimized to reduce wear on the outsole, increase shock attenuation, and shall not negatively affect the overall comfort of the item. Overall height of the bottoming, from the true feather line to the bottom of the outsole, shall not negatively affect overall item performance, user performance, or natural gait biomechanics. Bottoming must match the upper material color of Olive Mohave color number 200512. Bottoming must be durable enough to withstand standard use by Marines in a jungle, desert, and garrison environment while executing combat training and operations. The thickness of bottoming components shall be uniform between and within pairs. Edge scouring of the rubber outsole shall be smooth and regular for quality appearance and maintain a ledge of $1/4'' \pm 1/16''$. No bottoming component shall be malformed, contain air pockets, or contain wrinkles.

3.4.11.1 Solid midsole. The rubber midsole for use with stitchdown constructions shall be 5 iron ($\pm 1/2$ iron). The midsole shall be Olive Mohave color number 200512 in color matching the standard sample. The requirements shall be as specified in Table VI when tested as specified in paragraph 4.9.

3.4.11.2 Cushioned Midsole. The cushioned midsole shall provide the necessary stability, durability, and seek to increase the overall performance of the item by optimizing the performance called out in this specification (i.e. Weight, Shock Attenuation, etc) and meet the requirements specified below in paragraph 3.4.11.2.1 and in Table V when tested as specified in paragraph 4.9. The cushion midsole shall be Olive Mohave color number 200512 in color matching the standard sample and conform to the shade of the upper.

3.4.11.2.1 Polyether polyurethane requirements. The requirements for the midsole are based on testing done on slabs (according to ASTM procedures) and are not actual soles. The requirements shall be as specified in Table V when tested as specified in paragraph 4.9.

Table V. Cushioned Midsole Polyether Polyurethane Requirements

Characteristics	Minimum	Maximum
Density (gm/cc)	0.40	0.60
Hardness (shore A)	50	75
Tensile strength (kgf/cm sq)	25	-
Elongation (%)	350	-
Tear strength- Die T (kg/cm)	3.7	-
Volume swell (%) w/ ASTM Oil #3 (at 24 hrs)	-	10
Compression Set %	-	20
Ross flex (1x6 inch) at 5°C	900% @ 150,000 cycles	-

3.4.11.3 Outsole. The outsole shall be the Vibram Fire and Ice 360 Outsole in Olive Mohave color number 200512 to match the upper material and shall be non marking.

3.4.11.3.1 Rubber compound requirements. Outsole shall use Vibram Fire and Ice compound. The requirements for the rubber outsoles are based on the testing performed on 0.250 or 0.070 gauge inch test slabs (in accordance with ASTM procedures) and are not actual soles. There may be some deviation on actual outsoles or midsoles based on style thickness and curing parameters. The requirements shall be as specified in Table VI, when tested in accordance with paragraph 4.9.

Table VI. Rubber Compound (Outsole-Solid Midsole) Requirements

Characteristics	Outsole	5-iron midsole
NBS abrasion	120 min.	N/A
Hardness (shore A)	57-67 A	N/A
Stitch Tear (dry)	300 lb. min.	180 lb. min.
Stitch Tear (Fuel B)	50 lb. min.	50 lb. min.
Die C tear strength	250 lb. min.	N/A
Ross flex, Oil #3	250% max. @ 50,000 flexes	N/A
Volume swell, Fuel B (@ 46 hrs)	70% max.	N/A
Non-marking	Pass	N/A
Tensile	2,100 lb. Min	N/A
Elongation	400% min.	
Cold Flex @ -23° C	500% @7,500 flexes	N/A
Transitional Hardness (2 hrs @-23° C)	Max change + 10 point shore	N/A
Slip Index (cold/ice)	0.20 min (rough ice method)	N/A

3.4.11.4 Adhesive. The adhesive for laminating the layers together shall be such that the bonded layers will meet the requirements of this specification. The adhesive shall have no adverse health hazard when used as intended. UPACO brand adhesive is required.

3.4.12 Insoles. The insole shall meet the requirements specified in Table VII when tested as specified in paragraph 4.9.

Table VII. Insole Performance Requirements

Characteristics	Physical Requirements
Thickness	
Stitchdown Construction	0.095 +/- 0.010 inch
Fungal resistance	Level 10
Wet Tensile	70 kgf/cm ² min.
Flexing Index	3.7 (5000 cycles) min.
Abrasion Resistance	
Non-Woven board	25,600 revs dry/6400 wet (min.)
Transverse Tensile-Dry	8 kgf/cm ² min.
Dimensional Stability	0.7% max.
Peel Strength	0.5 kgf/cm ² min.

3.4.12.1 Insole board foam top-layer. Microcellular polyurethane foam, 0.125 (± 0.01) inch thick, shall be permanently attached to the top of the insole board. The foam shall meet the requirements of Table VIII when tested as specified in paragraph 4.9.

Table VIII. Insole Board Foam

Characteristics	Physical Requirements
Density	19-23 lb/cu.ft
Tensile strength	60 lb./sq. in. (min)
Compression set	
50% @ 73 degrees F	2 psi (max)
50% @ 158 degrees F	10 psi (max)
Resilience/Ball rebound	8 % (min)

3.4.13 Thread, nylon. The thread shall be Coats (Brand Name or Equal) T99 weight nylon with T92 for the bobbin for the upper stitching and waxed Coats (Brand Name or Equal) T693 weight for bottom stitching with T554 waxed bobbin thread, conforming to type I, II or III, class A or B, size E of V-T-295. The thread shall conform to the shade of the standard sample of Olive Mohave color number 200512. Colorfastness requirements shall not apply. The maximum thread elongation for all thread shall be 32 percent. Stitch per inch for the upper shall be 7-8 and 3-4 for the bottom.

3.4.14 Laces. The color of the laces shall be Olive Mojave shade 200512 and match the color of the upper leather. The laces shall not fray during use. The length of the laces shall be a minimum of 72 inches. Laces shall meet minimal requirements found in CID A-A-55093 (Type III, Class 1).

3.5 Lasts. The boot shall be constructed on the JV 610 hinged last. The boots shall be constructed on specific size lasts to the ½ size and each width to include N, R, W, XW. The numerical size of the boot shall correspond with the numerical size of the last used to produce the boot (i.e. a size 10R boot shall be produced on a size 10R last). Last design should optimize fit and comfort in conjunction with the overall item design to promote maximum adjustability for the user. Additionally, last design shall accommodate for the cushion insert.

3.6 Construction.

3.6.1 Cutting uppers. All leather parts shall conform to the thickness specified in Table IX. Vamps shall be cut from the bend area of the side leather and shall be examined as specified in Table XI.

TABLE IX. Thickness of leather uppers (ounces)

Thickness of leather uppers (ounces)		
Part	Class I Cattle Hide	
	Min	Max
Vamp	4.75	5.75
Foxing	4.75	5.75

Eyelet Stay	2.75	3.75
Gusset and Collar	2.75	3.75
Impregnated Leather (Scuff Toe)	3.75	4.75
Ankle Support Strap	4.75	5.75

3.6.2 Skiving. Skiving of upper is required where leather overlaps leather. Leather Vamps and Ankle Support Straps shall not be split. Skiving of the top edge of the outside counter-pocket shall not be permitted.

3.6.3 Sole stitching. Sole stitching shall use the lock-stitch, 3-4 stitches per inch. The lock shall be embedded in the solid midsole, but no more than one third of the way down from the interface with the upper. Testing shall be as specified in 4.10.5.

3.6.3.1 Double stitch at toe. A second stitch shall pass through the midsole and outsole. This stitch shall be directly in front of the primary stitchdown.

3.6.4 Boot finishing. No top finish or treatment shall be used on boots.

3.6.5 Marking, permanent identification. With the exception of PDMs, the Contractor shall permanently mark the correct size, width, contract number (Example: 03-D-9999), and company name on the inside of the upper, two inches down and centered on the medial side. The boot shall contain a manufacturing tracking lot number. A company logo or name is not permitted anywhere on the exterior of the boot. The permanent marking shall be done in accordance with acceptable commercial practices and shall not reduce footwear functionality. Heat embossing of the United States Marine Corps "Eagle, Globe, and Anchor" Logo is required on the outside quarter (heel area) on both the left and right boot. (See figure 1). The EGA shall be permanently marked anchor forward for both the left and right boot. The design detail of the EGA shall be clearly visible from a distance of three (3) feet. A recommended source of the EGA die is: Manufacturer's Supply, St. Louis, MO. Phone (314) 770-0880.

The die sizes for embossing of the EGA are as follows:

Boot Size	Die Size for the Eagle, Globe, and Anchor
Men's 3 through 7 ½	Small
Men's 8 through 10	Medium
Men's 10.5 through 16	Large

For non-depot shipments, each unit pack and exterior container shall be marked following standard commercial practices. Unit pack identification shall include the item name, NSN, and UPC with bar code, contract number, US sizes and widths and as an option, the contractor's name and/or logo. The initials "UPC" must appear under the UPC bar code. The exterior containers shall be marked to identify the NSNs with bar code, quantity, and unit of issue, date of pack, contract number, shipment number, pallet

gross weight and cube and a visible marking with the words “MADE FOR DLA TROOP SUPPORT”. Depot shipments for boots shall be marked in accordance with MIL-STD-129P.

3.7 Instruction and Hangtags.

3.7.1 Instruction tag. The instruction label/tag is to be tied to the finished boots and the print size shall be 8 to 10 points, 1/8 inch (+/- 1/32) inch. The instruction/label tag shall be printed using the data specified and approved by the government prior to full rate production. The information provided in Sections 3.7.1.1 through 3.7.1.6 must be included on the care and use instruction label/tag. Each item shall be individually bar-coded. The bar-coding element shall be a 13 digit national stock number (NSN). The bar-code type shall be a medium to high code density and shall be located so that it is completely visible on the item when it is folded and/or packaged as specified in the contract and so that it causes no damage to the item. As an option, component and boot feature hangtags may be attached to the boots.”

3.7.1.1 Safe use of your USMC RAT Temperate Weather Boots. “For the safe use of your USMC RAT Temperate Weather Boots: 1) Wear 1 pair of socks made of wool, acrylic, polyester, olefin, nylon, or lycra blend. Cushion soled socks are recommended. 2) Always wear with one pair insole inserts. In some instances it may be necessary to select a slightly larger size boot than normally worn in order to allow for normal swelling of the feet and the use of insole inserts or cushion socks. Pull on boot, seating heel firmly into place, then lace. Boots should fit snugly but not tightly. There should be at least a 3/8 inch minimum additional length at the toe. If blistering occurs, check to make sure that the boots are fitted properly and that you are wearing recommended socks.

3.7.1.2 Cleaning and Maintenance Instructions. “To Properly Clean and Maintain your USMC RAT Temperate Weather Boots: 1) Brush mud and excessive dust off boots with a stiff nylon bristle brush and warm water. These boots have a suede finish and are not to be polished. 2) Wipe inside of boots occasionally with a moist rag and let dry. 3) As frequently as possible, dry boots and insert in the sun. If boot becomes wet, empty excess water, change socks, and continue to wear while changing socks regularly. Boots will dry faster when worn than if left to stand and dry. Do not place near intense heat as this will destroy nylon and leather. 4) The nylon side panels of your boots are as strong as leather and will last if cared for properly. Do not use soap to clean your boots. If more stringent cleaning is necessary, only water soluble cleaning products should be used as oil- or alcohol- based cleaning products may damage your boots.”

3.7.1.3 When to Replace the USMC RAT Temperate Weather Boot Outsole. “Your USMC RAT Temperate Weather Boots come with a replaceable rubber outsole. Do not wear any part of the outsole past 1/16” (in thickness) or permanent damage of the cushioned midsole will occur. The midsole is the soft cushioned material between the rubber lug outsole and the boot upper. To find the repair retailers closest to you visit <http://www.vibram.com>.”

3.7.1.4 Purpose and Performance of the USMC RAT Temperate Weather Combat Boot. “Your USMC RAT Temperate Weather Boots are designed for maximum comfort and performance in temperate weather environments.”

3.7.1.5 Who to Contact for Questions about your USMC RAT Temperate Weather Boots. Must include information on who/how to contact within your company with questions regarding use and care of the USMC RAT Temperate Weather Combat Boot.

3.8 Workmanship. The quality of workmanship and end product for this item is expected to exceed that found in standard commercial industry given the known environment and user for which the item is being manufactured. The finished boots shall conform to the quality of product established by this document. The occurrence of defects shall not exceed the contractor's own quality assurance standards and the quality assurance standards defined by the technical data in the bid package. The government will not accept poor quality workmanship, manufacturing defects, or low quality end products.

3.8.1 Seams, Stitching, and Workmanship. All seams shall be uniformly stitched, and shall be locked such that it cannot be pulled out. Open seams, broken seams, or runoff stitches shall not be present. When multiple stitch seams are utilized, the stitching shall be regularly spaced between stitches and rows of stitches. Tight seams which cause components to pucker, wrinkle, or malform shall not be present. Loose seams shall not be present. Thread ends shall be trimmed throughout entire boot. Outsole seams (if utilized as specified in this document) shall not deform outsole pattern, and shall be uniform distance to edge of outsole. Stitching gage shall be regular, and needle holes or needle "chew" shall not be permitted. Internal seams shall not be such that they cause irritation, "hot-spots", blisters, or other damage to the user.

3.8.2 Seam Stitch Strength. The seam stitch strength shall not be less than 300 lbs for all the seams except for the gusset seam. The test shall be performed on the end item as specified in Table XVI. No recorded value shall fail below 300 lbs.

3.8.2.1 Gusset Seam Strength. The exposed two piece gusset seam stitch strength shall not be less than 80 lbs. The test shall be performed on the end item as specified in Table XVI. No recorded value shall fail below 80 lbs.

4. VERIFICATION

4.1 Responsibility for inspection. Unless otherwise specified in the contract or purchase order, the contractor is responsible for the performance of all inspection requirements (examinations and tests) as specified herein. Except as otherwise specified in the contract or purchase order, the contractor may use his own or any other facilities suitable for the performance of the inspection requirements specified herein, unless disapproved by the Government. The Government reserves the right to perform any of the inspections set forth in this specification where such inspections are deemed necessary to ensure supplies and services conform to prescribed requirements.

4.2 Responsibility for compliance. All items shall meet all requirements of Section 3. The inspection set forth in this specification shall become a part of the contractor's overall inspection system or quality program. The absence of any inspection requirements in the specification shall not relieve the contractor of the responsibility of ensuring that all products or supplies submitted to the Government for acceptance comply with all requirements of the contract. Sampling inspection, as part of manufacturing operations, is an acceptable practice to ascertain conformance to requirements, however, this does not authorize

submission of known defective material, either indicated or actual, nor does it commit the Government to accept defective material.

4.3 Responsibility for dimensional and material requirements. Unless otherwise specified in the contract or purchase order, the contractor is responsible for ensuring that all specified dimensions and material requirements have been met. When dimensions or materials cannot be examined on the end item, inspection shall be made at any or all points necessary within the manufacturing process to ensure compliance with dimensional requirements.

4.4 Certificates of Compliance. When certificates of compliance are submitted, the Government reserves the right to inspect and test such items to determine the validity of the certification.

4.5 Color and Shade Verification. All components referencing matching the standard shade and appearance shall be viewed using AATCC Evaluation Procedure 9, Option A, under filtered tungsten lamps that approximate artificial daylight D75 illuminant with a color temperature of 7500 ± 200 K, with illumination of 100 ± 20 foot. Color and Shade Verification of the Upper Leather, Gusset, and Quarter Panels shall be given based on the acceptable shade ranges determined by the USMC and based on the PDM acceptance. Nubuck Upper Leather color shall match Olive Hot Pocket Nubuck 492006. The Quarter Panels and Impregnated Leather must match USMC Olive Mohave color number 200512. Standard color swatches can be obtained from the Technical Support Team at SB Foot Tanning Co.

4.6 Classification of inspections. The inspection requirements specified herein are classified as follows:

- a. First article inspection and testing (see paragraph 4.7).
- b. Quality conformance inspection (see paragraph 4.8).

4.7 First article inspection. When a first article is required (see paragraphs 3.1 and 6.2), it shall be examined for defects and may be tested for any of the characteristics specified in this Purchase Description. Examples of defects not listed in the Purchase Description but which detrimentally effect item performance or user acceptance will not be accepted.

4.8 Quality conformance inspection. Unless otherwise specified, sampling for inspection shall be performed in accordance with ISO 9002, or ANSI/ASQC Z1.4.

4.9 Component and material inspection. A certificate of compliance may or may not be acceptable as evidence that the characteristics listed in Table X conform to the specified requirements depending on the confidence the government places in the alternate form of testing executed. The sampling plan for required component testing shall be as follows (excluding leather components):

LOT SIZE (YARDS/UNITS)	SAMPLE SIZE
22,000 and BELOW	5
22,001 to 80,000 (repeat) thru spec	8

TABLE X. Component Tests

RAT PD 13-01

Material	Characteristic	Requirement Paragraph	Test Method
Leather	Class I	3.4.1	IAW MIL-PRF-3122J <u>1/</u>
Laminated Cloth	Martindale Abrasion Fabric Only, Dry	3.4.3.1 Table II	ASTM 4966 <u>1/ 3/</u>
	Bursting Strength, Fabric Only	3.4.3.1 Table II	ASTM 3787 <u>1/</u>
	Hydrostatic Resistance (psi)		
	Liner cloth (initial)	3.4.3.1 Table II	ASTM D751 <u>1/ 4/</u>
	At Seam	3.4.3.1 Table II	ASTM D751 <u>1/ 5/</u>
	After Synthetic Perspiration	3.4.3.1 Table II	ASTM D751 <u>1/ 6/ 7/ 8/</u>
	After Diesel Fuel Oil	3.4.3.1 Table II	ASTM D751 <u>1/ 9/ 6/</u>
	Water Permeability Resistance		
	Liner cloth (initial)	3.4.3.1 Table II	AATCC 127 <u>1/ 10/</u>
	At Seam	3.4.3.1 Table II	AATCC 127 <u>1/ 11/10/</u>
	After Synthetic Perspiration	3.4.3.1 Table II	AATCC 127 <u>1/ 12/ 7/ 8/ 10/</u>
	After Diesel Fuel Oil	3.4.3.1 Table II	AATCC 127 <u>1/ 13/ 8/ 10/</u>
	Abrasive Durability (cycles to leak)		
	Back/ leather side	3.4.3.1 Table II	ASTM D3886 and AATCC 127 <u>1/ 14/ 10/</u>
	Moisture Vapor Transmission Rate		
	B Method	3.4.3.1 Table II	ASTM E96 <u>1/ 15/</u>
	BW Method	3.4.3.1 Table II	ASTM E96 <u>1/ 16/</u>
	Flex Durability		
	Gelbo (cycles to leak)	3.4.3.1 Table II	ASTM F392 and AATCC 127 <u>1/ 17/ 10/</u>
	Wet (hrs to leak)	3.4.3.1 Table II	ASTM F392 and AATCC 127 <u>1/ 18/ 10/</u>
Insole	Thickness	3.4.12 Table VII	
	Stitch down	3.4.12 Table VII	ASTM D 1777 <u>1/ 2/</u>
	Fungal resistance	3.4.12 Table VII	ASTM D 3273 <u>1/</u>
	Wet Tensile	3.4.12 Table VII	SATRA TM-2 <u>1</u>
	Flexing Index	3.4.12 Table VII	SATRA TM-3 <u>1/</u>
	Abrasion Resistance	3.4.12 Table VII	
	Non-Woven board	3.4.12 Table VII	SATRA TM-31 <u>1/</u>
	Transverse Tensile-Dry	3.4.12 Table VII	SATRA TM-80 <u>1/</u>
	Dimensional Stability	3.4.12 Table VII	SATRA TM-98 <u>1/</u>
	Peel Strength	3.4.12 Table VII	SATRA TM-101 <u>1/</u>

RAT PD 13-01

Insole Board Foam	Density	3.4.12.1 Table VIII	ASTM D-3574 <u>1/</u>
	Tensile strength	3.4.12.1 Table VIII	ASTM D-3574 <u>1/</u>
	Compression set	3.4.12.1 Table VIII	ASTM D-3574 <u>1/</u>
	Resilience/Ball rebound	3.4.12.1 Table VIII	ASTM D-3574 <u>1/</u>
Cushion Midsole (Polyether Polyurethane)	Density	3.4.11.2 Table V	ASTM D 3574 <u>1/</u>
	Hardness (Shore A)	3.4.11.2 Table V	ASTM D 2240 <u>1/</u>
	Tensile Strength	3.4.11.2 Table V	ASTM D 3574 <u>1/</u>
	Elongation	3.4.11.2 Table V	ASTM D 3574 <u>1/</u>
	Tear Strength	3.4.11.2 Table V	ASTM D 3574 <u>1/</u>
	Volume Swell	3.4.11.2 Table V	ASTM D 471 <u>1/</u>
	Compression Set	3.4.11.2 Table V	SATRA TM-64 <u>1/</u>
	Ross Flex	3.4.11.2 Table V	ASTM D 1052 <u>1/ 21/</u>
Midsole and Outsole (Rubber Compound)	Abrasive Index	3.4.11.1 , 3 Table VI	ASTM D-1630 <u>1/</u>
	Hardness (Shore A)	3.4.11.1 , 3 Table VI	ASTM D-2240 <u>1/</u>
	Volume Swell	3.4.11.1 , 3 Table VI	ASTM D-471 <u>1/</u>
	Stitch Tear	3.4.11.1 , 3 Table VI	ASTM D-4786 <u>1/</u>
	Stitch tear, Fuel B	3.4.11.1 , 3 Table VI	ASTM D-4786 <u>1/</u>
	Ross Flex Oil #3	3.4.11.1 , 3 Table VI	ASTM D-1052 <u>1/ 22/</u>
	Non-marking	3.4.11.1 , 3 Table VI	SATRA TM-223 <u>1/</u>
	Die C-Tear	3.4.11.1 , 3 Table VI	ASTM D- 624 <u>1/</u>
	Tensile Test	3.4.11.1 , 3 Table VI	ASTM D-412 <u>1/</u>
	Elongation Test	3.4.11.1 , 3 Table VI	ASTM D-412 <u>1/</u>
	Cold Flex @-23° C	3.4.11.1 , 3 Table VI	ASTM D-1052 <u>1/ 23/</u>
	Transitional Hardness (2 hrs @-23°C)	3.4.11.1 , 3 Table VI	ASTM D-2240 <u>1/</u>
	Slip Test	3.4.11.1 , 3 Table VI	SATRA TM 144 <u>1/</u>
Quarter Panels	Water Repellency	3.4.2 Table I	ATCC Method 22 <u>1/</u>
	MTVR (Breathability)	3.4.2 Table I	ASTM E96 (B) <u>1/</u>

RAT PD 13-01

Counter	Initial Collapsing Load (N)	3.4.8 Table IV	SATRA TM-83 <u>1/</u>
	Resilience (%)	3.4.8 Table IV	SATRA TM-83 <u>1/ 19/</u>
	Moisture Resistance (%)	3.4.8 Table IV	SATRA TM-83 <u>1/20/</u>
	Area Shape Retention (%)	3.4.8 Table IV	SATRA TM-83 <u>1/</u>
Removable Cushion Inserts	Density	3.4.5 Table III	ASTM D 3574 <u>1/</u>
	Foam hardness	3.4.5 Table III	ASTM D 2240 <u>1/</u>
	Tensile strength	3.4.5 Table III	ASTM D 3574 <u>1/</u>
	Compression set @ 25%	3.4.5 Table III	ASTM D 3574 <u>1/</u>
	Compression set @ 50%	3.4.5 Table III	ASTM D 3574 <u>1/</u>
Removable Cushion Insert Fabric Top Cover:	Martindale Abrasion		
	Fabric Only; Dry	3.4.5 Table III	ASTM D 4966 <u>3/ 1/</u>
	Bursting Strength		
	Fabric Only	3.4.5 Table III	ASTM D 3787 <u>1/</u>
Box Toe		3.4.7	<u>1/</u>
Binding Tape		3.4.4	<u>1/</u>
Shanks		3.4.9	<u>1/</u>
Eyelets		3.4.10	<u>1/</u>
Speedlace		3.4.10	<u>1/</u>
Thread, nylon		3.4.13	<u>1/</u>

1/ A Certificate of Compliance shall be submitted and will be acceptable for the stated requirement.

2/ A thickness gauge of the dead-weight type equipped with a dial graduated to read directly to 0.001 inches shall be used. The presser foot shall be circular, with a diameter of 1.129 (\pm 0.001) inches and with moving parts weighted to apply a total load of 0.60 (\pm 0.03) pounds per square inch (psi) to the specimen. The anvil shall be not less than 1.129 inches in diameter. The presser foot and anvil surface shall be planed to within 0.001 inches and shall be parallel to each other to within 0.001 inches.

3/ Martindale Tester; Pressure applied: 12 kPa; visually examine specimens after each 3200 cycles; abradant changed after each 3200 cycles. Use Option 1 for evaluation; no hole appears.

4/ Test 5 samples in accordance with ASTM D 751 Procedure A1 with the face (foot side) of the liner cloth in contact with the water.

5/ Test 5 samples containing sealed seams in accordance with ASTM D751 Procedure A1 with the face (foot side) of the liner cloth in contact with the water and the seam centrally located in the circular orifice.

6/ Test 5 samples, four inch by four inch (4" x 4"), cut from the laminate material and exposed to contamination, synthetic perspiration (Footnote 5). Contaminate prior to leak testing by dispensing 2 ml

of perspiration solution on both sides of the sample (see Footnote 6 for contamination procedure.) Determine hydrostatic resistance in accordance with ASTM D751 Procedure A1 with the face (foot side) of the liner cloth in contact with the water.

7/ Synthetic perspiration shall be made up in a 500 ml glass beaker by combining 3.0 grams sodium chloride, 1.0 gram trypticase soy broth powder, 1.0 gram normal propyl propionate, and 0.5 grams of liquid lecithin. Add 500 ml of distilled water, add a magnetic stirring bar and cover beaker. Place the beaker on a combination hot plate/ magnetic stirring apparatus. While stirring, heat the solution to 50 degrees C until all ingredients are dissolved. Then, while stirring, cool solution to 35 degrees C.

8/ Dispense contaminate on to the center of a glass plate (4 inches by 4 inches by 0.25inch thick.). Sample shall be placed face down on the plate and an additional contaminate dispensed on the backside. Place a second glass plate on the sample. Next, position a 4-pound weight on the center of the second glass plate. After 16 hours, remove the sample (do not rinse) and test immediately.

9/ Test 5 samples, four inches by four inches (4" x 4"), cut from the laminate material and exposed to diesel fuel as follows: Contaminate prior to leak testing by dispensing 3 drops of diesel fuel onto both sides of the sample (see Footnote 6 for contamination procedure.) Determine hydrostatic resistance in accordance with ASTM D751 Procedure A1 with the face (foot side) of the liner cloth in contact with the water.

10/ Test 5 samples in accordance with AATCC 127 with face/ foot side towards water. Suter test conditions shall be 7 psi (50 cm), for 5 minutes. Any observed water droplets in test area constitutes a failure.

11/ Test 5 samples containing sealed seams in accordance with AATCC 127 with the face (foot side) of the liner cloth in contact with the water and the seam centrally located in the circular orifice. Follow Suter test conditions and inspection as specified in Footnote 8.

12/ Test 5 samples, four inches by four inches (8" x 8"), cut from the laminate material and exposed to synthetic perspiration (Footnote 5.) Contaminate prior to leak testing by dispensing 2 ml of perspiration solution on both sides of the sample (see Footnote 6 for contamination procedure.) Determine water resistance in accordance with AATCC 127 with the face (foot side) of the liner cloth in contact with the water. Follow Suter test conditions and inspection specified in Footnote 8.

13/ Oil Test 5 samples, four inches by four inches (8" x 8"), cut from the laminate material and exposed to diesel fuel as follows: Contaminate prior to leak testing by dispensing 3 drops of diesel fuel onto both sides of the sample (see Footnote 6 for contamination procedure.) Determine water resistance in accordance with AATCC 127 with the face (foot side) of the liner cloth in contact with the water. Follow Suter test conditions and inspection as specified in Footnote 8.

14/ Test back side of 5 laminate samples in accordance with ASTM D3886. Non-contact pin diaphragm approved for use to decrease variability. The test is to be run for the specified number of cycles prior to testing for leakage. Leakage shall be determined in accordance with AATCC 127. Follow Suter test conditions and inspection as specified in Footnote 8.

15/ Determine MVTR in accordance with ASTM E96 method B with the back side of the test cloth shall face the water. The free stream air velocity shall be 550 (\pm 50) fpm as measured 2 inches above the specimen. The airflow shall be measured at least 2 inches from any other surface. The test shall be run for 24 hours and weight measurements shall be taken at only the start and completion of the test. At the start of the 24-hour test period, the air gap between the water surface and the specimen shall be 0.75 (\pm 0.06) inches.

16/ Determine MVTR in accordance with ASTM E96 method BW with the backside of the test cloth facing the water. The free stream air velocity shall be 550 (\pm 50) fpm as measured 2 inches above the specimen. The airflow shall be measured at least 2 inches from any other surface. The specimen shall be sealed to the cup in any manner that prevents wicking or leaking of water out of the cup. The test shall be run for 2 hours and weight measurements shall be taken at only, the start and completion of the test.

17/ Test one sample, 8 in. by 12 in., shall be conditioned and flexed in accordance with ASTM F392 except specimen shall not be aged, the short edges shall not be heat sealed or otherwise joined, and the specimen shall be flexed for the specified number of cycles. Two, 6 in. by 8 in. specimens shall be cut from the flexed sample and tested for leakage in accordance with AATCC 127. Follow Suter test conditions and inspection as specified in Footnote 8.

18/ One sample, 14 inches by full width, shall be selected from a sample unit and tested for leakage after the required number of hours of continuous agitation. The specimen shall be agitated using the “normal,” cycle in an automatic home laundering machine except that the washing machine shall be capable of continuous agitation. The water level shall be maintained at 16 (\pm 0.5) gallons, and the water temperature shall be 32 (\pm 9 degrees C). Additional fabric shall be added to the specimen to create a load weight of 2 (\pm 0.2) pounds. Upon completion of the continuous agitation the specimen is to be air dried and then tested for leakage in accordance with AATCC 127. Follow Suter test conditions and inspection as specified in Footnote 8.

19/ Resilience is percentage retention of initial collapsing load after ten collapses.

20/ Moisture resistance is percentage retention of initial dry collapsing load after 1 hour immersion.

21/ Method modified to include 2.0 mm insole board glued onto the specimens, -5 degrees and conditioned for 2 hours.

22/ One (1) drop of oil per 6,000 flexes.

23/ Test conducted after 2 hours conditioning.

4.9.1 In-process inspection. Inspection shall be made at any point or during any phase of manufacturing to determine whether the components are as specified or operations and/or assemblies are accomplished as specified. The Government reserves the right to exclude from consideration for acceptance any material or service for which in-process inspection has indicated nonconformance.

4.9.1.1 In-process examination. The defects found during in-process examination will not be accepted. The lot size shall be expressed in units of upper assemblies prepared for lasting. The sample unit shall be one completely fabricated upper assembly prepared for lasting.

4.9.1.2 Pre-fitting examination of cut parts. The cut parts shall be examined for the defects listed in Table XI before fitting. The lot size shall be expressed in units of cut parts. The sample unit shall be one cut part. Defects not listed in Table XI but which detrimentally effect items performance or user acceptance will not be accepted.

TABLE XI. Cut parts defects

Examine	Defect
Upper leather	Not a Nubuck
	Leather deeply snuffed; i.e., fiber structure damaged
	Grub or tick damage, scratches, brands, or bony leather
	Fat wrinkles or veins
	Not struck through
	Stretchy vamp
	Leather embossed or printed where not specified
	Thickness exceeding the maximum or less than the minimum specified
	Rough fiber on flesh side
	Off-stretch cut
	Slaughter cut
Quarter side panels	Not as specified in color or pattern
	Hole, spot, stain, foreign matter, cut, tear, mis weave
Upper Design	Not as accepted for contract award and by PDM

4.9.1.3 Examination of uppers after all fitting. The upper assemblies shall be examined for the defects listed in Table XII. The lot size shall be expressed in units of upper assemblies prepared for lasting. The sample unit shall be one completely fabricated upper assembly prepared for lasting. Defects not listed in Table XII but which detrimentally effect items performance or user acceptance will not be accepted.

Table XII. Examination of uppers after all fitting

Examine	Defect	Classification	
		Major	Minor
Construction and workmanship (general) affixed	Any component missing or not specified type	101	
	Any component misplaced or not affixed as specified/properly		<u>1</u> /
	Any cut, tear, hole, repair, or factory damage		<u>1</u> /
	Back seam malformed	102	
Lining	Torn, loose, or wrinkled		<u>1</u> /

	Not properly mated with upper	103	
	Poorly stitched, frayed, or discolored	104	
Quality of leather	Thickness more than 1/2 ounce less than minimum specified	105	
	Thickness less than specified minimum, but not exceeding 1/2 ounce less		1/
	Thickness more than maximum specified		1/
	Off-stretch cut		1/
	Slaughter cut		1/

1/ This defect shall be scored as major when seriously affecting serviceability, and as a minor when affecting serviceability.

4.9.1.4 Examination of boot before last pulling. The partially fabricated boots shall be examined for the defects listed in Table XIII. The lot size shall be expressed in units of partially fabricated boots. The sample unit shall be one partially constructed boot assembled to the point just prior to pulling off the last.

TABLE XIII. Examination of Boot Before Last Pulling Defects

Examine	Defects	Classification	
		Major	Minor
Bottom of boot	Any component missing, sized wrong, malformed or not specified type	106	
	Upper damaged		1/
	Poor heel seat, side, or toe lasting		1/
	Insole tack not removed	107	
Upper Part of Boot	Uppers not firmly pulled down to last		1/
	Lace openings less than 5/8 inches or more than 7/8 inches	108	

1/ This defect shall be scored as major when seriously affecting serviceability, and as a minor when affecting serviceability.

4.9.1.5 In process examination of boot before bottom filling. The partially fabricated boots shall be examined for the defects listed in Table XIV. The lot size shall be expressed in units of partially fabricated boots. The sample unit shall be one partially constructed boot assembled to the point after lasting and attachment of shank, but before Bottoming. Defects not listed in Table XIV but which detrimentally effect items performance or user acceptance will not be accepted.

TABLE XIV. Boot Before Bottom Filling Defects.

Examine	Defect
Bottom of boot	Any component missing or not specified type
	Shank not properly positioned or not fitting contour of boot bottom
	Shank wrong size, malformed, or not securely attached
	Upper damaged
	Poor heel seat, side, or toe lasting

	Inseam not properly trimmed
	Inseam stitches broken, skipped inseam stitches, or inseam stitches cut or damaged during trimming operation not repaired
	End of counter not caught in inseam stitching

4.9.2 End item visual examination. The end items shall be examined for the defects listed in Table XV below. Table XV gives examples of defects and is not inclusive. The lot size shall be expressed in units of boots. The inspector shall check to see that cushion inserts are inserted in the boots. For the pairing examination, and when determining possible differences in outsole thickness, the pair shall be examined together. During the inspection for the defects listed within the "End item visual defect table", defects shall be observed and recorded. Defects of pairing shall be classified as a single defect. Presence of these defects may not result in the rejection of the entire lot, but the plant quality assurance and Government personnel reserve the right to establish and impose lot rejection criteria when either the quantity, severity, or the presence of these departures warrant. These rejection criteria may be invoked at any time during the life of the contract when the Government judges this action to be in their best interest. Defects not listed in Table XV but which detrimentally effect items performance or user acceptance will not be accepted. Appearance conditions shall be classified as defects when the condition is plainly visible at a distance of 3 feet or more and it appreciably affects item appearance, or affects item performance.

TABLE XV. End Item Visual Defects.

Examine	Defect	Classification	
		Major	Minor
Pairing	Not properly mated; i.e., not right and left of same size	109	
	Variation in color or appearance		<u>1/</u>
	Variation of more than 1/4 inch in height of pair		<u>1/</u>
	Box toe malformed	110	
	Difference in outsole thick-ness between left and right boots or between pairs.		<u>1/</u>
	- more than 3/32inch	111	
	- more than 1/16 inch but less than 3/32		<u>1/</u>
Cleanness	Any non-removable spot, stain, or foreign matter effecting appearance		<u>1/</u>
Color and nap	Color not as specified	112	
	Nap not sueded uniformly		<u>1/</u>
	Any leather not struck through		<u>1/</u>
Design	Not as specified by PDM acceptance photos	113	
Construction and Workmanship (General)	Any cut, tear, hole, repair or damage	114	
	Any component or assembly omitted or misplaced, operation omitted or not properly performed	115	
	Wrinkled or bunched area at the back seam		<u>1/</u>
Seams and Stitching (upper)	Open seam not repaired	116	
	Repair of open seam not as specified	117	
	Stitch not locked, easily pulled out.	118	
	Tight tension resulting in puckering or cutting of the leather		<u>1/</u>
	Loose tension resulting in a loosely secured seam		<u>1/</u>

RAT PD 13-01

	Stitching omitted where required	119	
	Gage of stitching irregular		<u>1/</u>
	Thread ends not trimmed throughout the boot		<u>1/</u>
	Needle holes or needle chew		<u>1/</u>
	One or more run-off stitches		<u>1/</u>
NOTE: A seam shall be classified as open when one or more stitches joining a seam are broken or when two or more consecutive skipped or run-off stitches occur. On multiple stitched seams, a seam is considered open when either one or both sides of the seam are open. When the above conditions occur on the inside of the boot, it shall be scored as a footnote (<u>1/</u>) defect.			
Vamp stitching at outsole junction	One or more rows of defective stitching not repaired	120	
	Repaired but first stitch more than 1/4 inch from outsole junction		<u>1/</u>
	Repaired with one stitch in lieu of two or more stitches		<u>1/</u>
Outsole, Bottoming, & heel	Thickness not as specified		<u>1/</u>
	Edge scouring is irregular, effecting appearance		<u>1/</u>
	Any malformation, air bubbles, wrinkles, etc		<u>1/</u>
	Any component not uniform in thickness		<u>1/</u>
	Incomplete or incorrect bonding of outersole to cushion midsole (i.e., not securely attached)	121	
	Incomplete or incorrect bonding of rubber midsole to cushion midsole (i.e., not securely attached)	122	
Insole	Any protruding lasting staple or prong	123	
	Any protruding shank prong on insole	124	
Eyelet/speed laces	Number of eyelets/speed laces not as specified in each row		<u>1/</u>
	Not the same number of eyelets/speed laces in each row	125	
	Eyelets/speed laces not properly spaced within the row or misalignment between the rows to an extent interfering with proper lacing		<u>1/</u>
	Any eyelet/speed lace not securely clinched		<u>1/</u>
	Speed laces not perpendicular to edge of quarters or parallel to each other		<u>1/</u>
Marking, instruction tag, care and use manual	Missing, incomplete, incorrect, not applied in the specific manner, misplaced, illegible, or not specified size		<u>1/</u>
Lining	Torn, loose, wrinkled, discolored		<u>1/</u>
	Not properly mated with upper		<u>1/</u>
Counter	Not properly seated		<u>1/</u>
	Soft counter		<u>1/</u>
Bar-code label / tag	Bar-code omitted or not readable by scanner; human-readable		<u>1/</u>
	Interpretation (HRI) omitted or illegible, bar-coded typed not as specified; code density not as specified		<u>1/</u>
Cushion Insert	Missing, wrong size, or wrong side up, PU not uniform		<u>1/</u>

1/ This defect shall be scored as major when seriously affecting serviceability or appearance, and as minor when affecting serviceability.

4.9.3 End item testing. The finished boot shall be tested for the characteristics listed in Table XVI. The sample unit for all tests shall be one boot. All test results shall contain the individual values utilized in expressing the final result. For all tests, the sample size shall be five (5) boots regardless of lot size and the lot shall be unacceptable if one or more sample units fail to meet any requirement specified. The government reserves the right to draw samples from any production lot and perform any tests deemed necessary at any time during the term of the contract for verification of the contractor's certificates of compliance.

Table XVI. End Item Tests

Characteristics	Requirements Paragraph	Test Method	Number of Determinations Per Sample Unit
Bond Strength	3.3.5		
Solid Midsole to Upper	3.3.5.1	4.10.3	1
Outsole To Cushion Midsole	3.3.5.2	4.10.4	1
Solid Midsole to Cushion Midsole	3.3.5.3	4.10.4	1
Sole Lock-Stitch Placement	3.6.3	4.10.5	6
Weight	3.3.1	Standard	1
Shock Attenuation	3.3.3	ASTM F1614	3
Whole Boot MVTR	3.3.7	10.10.2	1
Leakage	3.3.10	4.10.1	1
Seam Stitch Strength	3.8.2	ASTM D1683	1
Gusset Seam Stitch Strength	3.8.2.1	ASTM D1683	1

NOTE: Test results for each specification shall be reported as Pass/Fail and test values.

4.10 Methods of test.

4.10.1 Boot leakage test. The boot leakage test shall be designed to indicate leakage by using water as a liquid medium through the boot by means of a whole shoe flex test (IAW SATRA MTM 77, modified as indicated below) while the boot is submerged. The minimum standard for passing this test is 100,000 wet flexes. Each boot shall be preconditioned by flexing IAW SATRA MTM 77, DRY with a foot form of steel shot for 100,000 flexes.

4.10.1.1 Apparatus. SATRA Model STM 184H whole shoe flexing apparatus or equal will be used allowing the end item to be submerged to a depth of the mid-point between the third and fourth eyelet. The mechanism for flexing on any other apparatus must be exactly the same as the SATRA Model STM 184H. The sides of the apparatus must be raised to alleviate splashing on the mechanism for flexing.

4.10.1.2 Procedure. Testing will be IAW SATRA MTM 77 at 140 (+/-10) flexes/minute and 45 degrees for each flex cycle. A SATRA Model STM 184H whole boot flex apparatus or equal must be used so that the water depth required can be achieved. The top of each item must be sealed appropriately so that the water splashing from the test does not enter through the top of the boot. Absorbent blotting paper will be “balled up” and placed within the boot upper so that any water ingress through the top or upper can be determined. A change in the color between the top and the bottom sections of the absorbent blotting paper will indicate water ingress. The steel shot foot-form shall be removed for testing in water. The end item shall be checked at 100,000 cycles for leakage, as indicated by a color change in the absorbent blotting paper within the boot.

4.10.1.3 Method of inspection. End items will be evaluated in accordance with IAW SATRA MTM 77, by checking for a change in color of the absorbent blotting paper that is “balled up” and placed within the boot upper. If water enters the top of the boot during the test, new absorbent blotting paper shall be inserted for the remainder of the test, unless the water has leaked to below the fourth eyelet.

If water has definitely leaked through the top of the boot by splashing and reached to below the fourth eyelet, then the whole boot must be dried and the absorbent blotting paper replaced before the test is resumed. Water ingress into the boot by way of wicking up the boot upper (outside) and down into the boot lining (inside) will not be considered an item failure. If it cannot be determined if the water has entered through the top or upper of the boot, a new boot shall be requested and subjected to the test.

4.10.2 Whole boot breathability. The boot breathability test shall be designed to indicate the Moisture Vapor Transmission Rate (MVTR) through the boot by means of a difference in concentration of moisture vapor between the interior and the exterior environment.

4.10.2.1 Apparatus.

- a. The external test environment control system shall be capable of maintaining 23 (± 1)°C and 50 (± 2) percent relative humidity throughout the test duration.
- b. The weight scale shall be capable of determining weight of boots filled with water to an accuracy of (± 0.01) gram.
- c. The water holding bootie insert (WHBI) shall be flexible so that it can be inserted into the boot and conform to the interior contours; it must be thin enough so that folds do not create air gaps; it must have a MVTR value ranging between 920-990 grams/square meter/24 hour. ASTM E 96 B - Standard Test Methods for Water Vapor Transmission of Materials shall be used to determine acceptability (1/); and it must be waterproof so that only moisture vapor contacts the interior of the footwear product rather than liquid water. After every five (5) uses of the WHBI it will be disposed of and replaced.
- d. The water circulating bath system for the boot shall be capable of controlling the temperature of the water uniformly in the boot to 35 (± 1)°C as measured in the toe area of the boot.
- e. The footform assembly used with the water circulating bath system shall have a boot plug oriented 12.5 centimeters (5 - inches) as measured from the bottom of the plug surface to the inside sole in the heel area.
- f. The boot plug shall be oval shaped measuring 3.5 - inches by 2.5 - inches.
- g. The top of the boot shall be sealed to create an impervious barrier to both liquid water and water vapor.

- h. Boots should be laced to the top of the lacing system. Allow for 1 (± 0.5) inch separation between lateral and medial eyelet stays, with possible exception of the eyelets at the top of boot and boot plug area. Maximize seal security at top of boot.
- i. A stationary 6-inch diameter fan shall be used to create the air current past the boot.
- j. The stationary fan shall be positioned perpendicular to the test surface and raised so the center of the fan is 5-inches from the test surface.
- k. The air current origin shall be 15.5 - inches from the back heel edge of the boot (D). Refer to Diagram 1.
- l. The air current shall be 250 (± 30) feet/minute at the heel edge of the boot (S). Measurement shall be taken without the boot assembly in place 2-inches up from the test surface at the fan center.

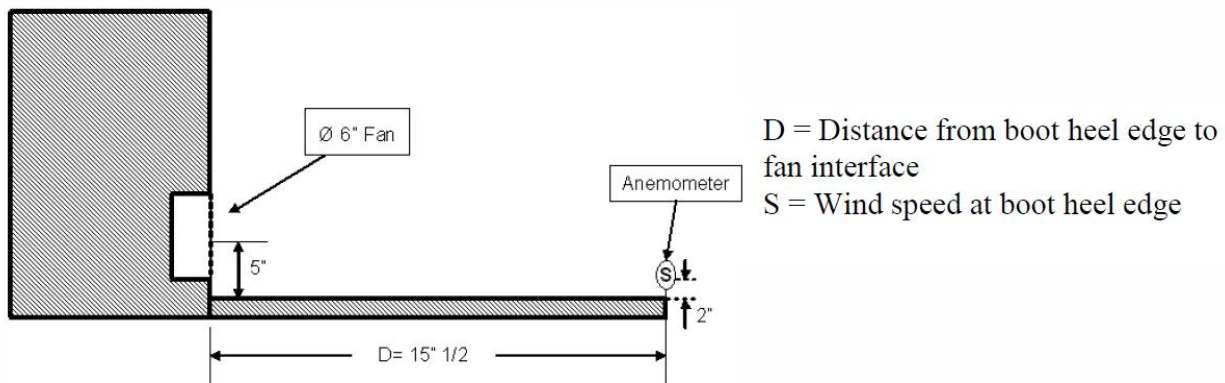

DIAGRAM 1. Whole Boot Breathability Bench-top Set-Up

1/ Determine MVTR in accordance with ASTM E96 method B with the knit side of the membrane facing the water. The free stream air velocity shall be 550 (± 50) feet per minute (fpm) as measured 2 inches above the specimen. The airflow shall be measured at least 2 inches from any other surface. The test shall be run for 24 hours and weight measurements shall be taken at only the start and completion of the test. At the start of the 24-hour test period, the air gap between the water surface and the specimen shall be 0.75 (± 0.06) inches.

4.10.2.2 Procedure.

- a. Remove the removable cushion insert from the boot sample.
- b. Weigh boot sample and record (this will be the unconditioned weight).
- c. The boot shall be conditioned in the test environment for a minimum of 12 hours before testing.
- d. Insert WHBI and footform assembly into boot opening and fill with water preheated to 35 (± 1) $^{\circ}$ C to a height of 12.5 centimeters (5-inches) as measured from the inside sole in the heel area and seal opening with boot plug. The water should be in contact with the bottom of the boot plug.
- e. Regulate water temperature in boot at 35 (± 1) $^{\circ}$ C.
- f. Disconnect water circulating system and weigh boot assembly and record as W_i . The water volume in system shall be noted at the time of weighing.

- g. After weighing reconnect water circulating system and maintain the temperature in boot at 35 (± 1)°C for 6 hours (± 5 minutes).
- h. The boot assembly shall be oriented such that the boot sole lies flat on the testing surface with the heel furthest from the fan interface and in line with the center of the stationary fan (See Diagram 2).

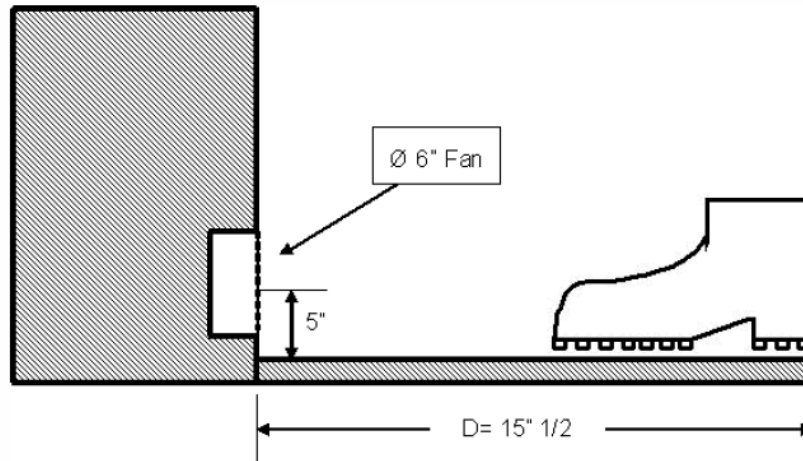

DIAGRAM 2. Whole Boot Breathability Bench-top Set-Up with Boot

- i. After 6 hours (± 5 minutes), reweigh boot assembly. The water volume in system shall match the noted W_i volume. Record weight as W_f and test duration as 6 hours.
- j. Compute whole boot MVTR in grams/hour from the equation below:
- k. If test is aborted for any reason, thoroughly dry boot to within 5 grams of original boot weight (Step b). Recondition boot sample in test environment for the required length as outlined, and begin test procedure again.

4.10.2.3 Method of Inspection. Each boot shall be tested in accordance with the method described in paragraph 4.10.2. The average whole boot MVTR from the 5 boots tested shall be greater than 3.0 grams/hour to satisfy the breathability standard.

4.10.3 Solid Midsole to the Upper Bond Strength. (For Stitchdown Construction Only)

4.10.3.1 Specimen. (Sample Men's 10R) The specimen shall be one boot on which the sole has aged at least 2 days after bonding. The test specimen shall consist of the heel counter portion of the test sample upper, to include all of the layers of the sole from the apex of the heel to the edge of the heel counter foxing.

4.10.3.2 Apparatus. A power-driven portable tensile tester machine, or an approved portable testing device of equal performance, shall be used. The rate of travel of the power-actuated grip shall be 4 inches per minute. The machine shall be operated with a device for maintaining maximum load indication and a heel mounting fixture.

4.10.3.3 Procedure. The specimen shall be attached to the heel mounting fixture of the machine. The apex of the heel portion of the specimen shall be centered and in alignment with the power-actuated grip. The machine shall be started, and the surface being tested (i.e. upper/counter to solid midsole) shall be pulled apart to a distance not more than 0.125 inches. Upon attaining that degree of separation, the maximum load indicated on the machine shall be read and recorded. If the required load is achieved (at any time during the pull test), the test is deemed as passing.

4.10.4 Midsole to Cushion Midsole and Outsole to Cushion Midsole Bond Strength.

4.10.4.1 Specimen. (Sample Men's 10R) The specimen shall be one boot on which the sole has aged at least 2 days after bonding. The two layers of the surface being tested shall be separated for a distance of approximately 2.5 inches from the toe end of the specimen.

4.10.4.2 Apparatus. A power-driven portable tensile tester machine, or an approved portable testing device of equal performance, shall be used. The rate of travel of the power-actuated grip shall be 2 inches per minute. The machine shall be operated with a device for maintaining maximum load indication.

4.10.4.3 Procedure. The separate toe ends of the specimen shall be clamped in the jaws of the machine. The specimen shall extend outward at right angles to the direction of the application load. The machine shall be started, and the surface being tested (i.e. upper to base, base to midsole, or midsole to outsole) shall be pulled apart to a distance not more than 4.5 inches from the toe. Upon attaining that degree of separation, the maximum load indicated on the machine shall be read and recorded. If the required load is achieved (at any time during the pull test), the test is deemed as passing. The procedure shall be repeated for each surface tested.

4.10.5 Sole Lock-Stitch Placement. (For Stitchdown Construction Only)

4.10.5.1 Specimen. (Sample Men's 10R) The specimen shall be one boot on which the sole has aged at least 2 days after bonding. The test specimen shall consist of the entire sole portion of the test sample minus the upper above the stitchdown. The insole and shank shall be removed.

4.10.5.2 Apparatus. A manual cutting knife shall be used.

4.10.5.3 Procedure. The specimen shall be cut perpendicular to the stitchdown. The cut shall be directly to the side of the lock and deep enough to provide adequate visibility to the position of the embedded lockstitch. The position of the lockstitch shall be recorded. The position of the lockstitch shall be determined for Six (6) locations around the perimeter of the sole.

5. PACKAGING

5.1 Packaging. For acquisition purposes, the packaging requirements shall be as specified in the contract or order by the procurement activity (see 6.2). Each box shall be marked to indicate quantity, size(s), width(s), and name of item within. Unit Packs will include NSN and UPC bar codes as specified in the contract. Each symbol must be Human and scanner readable.

Six (6) pair of boots, composed of one size and width shall be packed in a fiberboard shipping container conforming to type CF (variety SW) or CF, class domestic, Grade 275 of ASTM D5118/ D5118M. Closure shall be in accordance with ASTM D1974. The selection of the closure material shall be at the discretion of the contractor. The boot unit packs will be placed on end, such that the unit pack label is clearly visible from the top of an open shipping container. Each shipping container will contain only one NSN.

Palletized loads shall contain only one NSN to the maximum extent possible. Pallets may have exterior containers not of the same NSN, but the pallet must be clearly marked "MIXED" and each applicable NSN shall be listed with its total quantity. The outer dimensions and stacking pattern of the pallet shall be such that it forms a compact, squared load centered on the base and squared on all corners.

5.2 Label/Tag. Each item shall be individually bar-coded with the type VIII, class 17 label/tag of DDD-L-20. This label/tag shall be located so that it is completely visible on the item when it is folded and/or packaged as specified in the contract and so that it causes no damage to the item.

6. NOTES

6.1 Intended use. The boots are intended for wear by military personnel of the Department of Defense in the desert, jungle, garrison, and combat operations. As the combat environment is more severe than that seen during commercial wear and use, it is expected that the items procured by the US Government will be superior to those found commercially. Any item not meeting the performance(s) specified herein, or which does not meet commercial standards for retail production and purchasing will not be accepted by the US Government for use by its Military personnel.

6.2 Acquisition requirements. Acquisition documents should specify the following:

- a. Title, number and date of this specification.
- b. Types, classes and sizes required (see paragraph 1.2).
- c. Issue of DODISS to be cited in the solicitation and, if required, the specific issue of individual documents referenced (see paragraphs 2.2.1 and 2.2.2).
- d. When first article inspection is required, (see paragraph 3.1), the item will be tested and should be a first article sample.

The contracting officer should include specific instructions in acquisition documents regarding arrangement for examinations, quantity, and testing and approval.

6.3 First article. When a first article is required, it shall be inspected and approved under the appropriate provisions of Federal Acquisition Regulation (FAR) 52.209-4. The first article should be a pre-production sample. The contracting officer should specify the appropriate type of first article and the number of units to be furnished. The contracting officer should also include specific instructions in acquisition documents regarding arrangements for selection, inspection, and approval of the first article. (See 3.1 and 4.4)

6.4 Certificate of Compliance. When certificates of compliance are submitted for a stated requirement, the Government reserves the right to inspect and test such items to determine the validity of the certification.

6.5 International standardization agreements. Certain provisions of this document are the subjects of international standardization agreement as cited in NATO STANAG 2333. When amendment, revision, or cancellation of this document is proposed that will effect or violate the international agreement concerned, the preparing activity will take appropriate reconciliation action through international standardization channels including departmental standardization office, if required.

6.6 Changes to Components. Manufacturers are not authorized to substitute "or equal" items without prior written consent of the contracting officer. Prior to use or replacement of an "or equal" item, the contractor shall submit the item with supporting data to the contracting officer for subsequent approval or disapproval by the responsible military agency. If deemed necessary, the government reserves the right to test the RAT Temperate Weather Boot in the field with the "or equal" component prior to approval of the "or equal" component. The product specifications as stated in section 3.0 "Requirements" are the minimum physical requirements and any "or equal" delivered under the contract must meet these specifications. Any subsequent substitution of a component not in the PDM accepted for contract award without written consent of the Contracting Officer is grounds for immediate contract termination and is considered fraudulent to the US Government.

6.7 Subject term (key word) listing.

Footwear
Olive Mohave color number 200512
Leather
Inserts
Outsoles

6.8 Changes from previous issue. Marginal notations are not used in this revision to identify changes with respect to the previous issue due to the extensiveness of the changes.

Figure 1: USMC "Eagle Globe and Anchor" (EGA) Logo

The Eagle, Globe, and Anchor shall be heat embossed on the ankle of the boot as shown. The design shall be upright, and the wings of the eagle shall be parallel to the bottom of the outsole. The EGA shall be permanently marked anchor forward for both the left and right boot.



Figure 2A. Medial (Inside) View



Figure 2B. Lateral (Outside) View

