

MHI
Copy 3

FM 100-15

DEPARTMENT OF THE ARMY FIELD MANUAL

LARGER UNITS
THEATER ARMY-CORPS



HEADQUARTERS, DEPARTMENT OF THE ARMY
DECEMBER 1968

FIELD MANUAL }
 No. 100-15 }

HEADQUARTERS
 DEPARTMENT OF THE ARMY
 WASHINGTON, D.C., 27 December 1968

LARGER UNITS
 THEATER ARMY—CORPS

	Paragraph	Page
CHAPTER 1. INTRODUCTION	1-1-1-5	1-1
2. THE ARMY ROLE	2-1-2-3	2-1
3. ORGANIZATION AND FUNCTIONS		
Section I. High command	3-1-3-5	3-1
II. Theater (area) of operations	3-6-3-10	3-1
III. Organization of a U.S. theater of operations	3-11-3-18	3-4
IV. Theater planning	3-19-3-24	3-9
CHAPTER 4. THEATER ARMY MISSION, ORGANIZATION, AND FUNCTIONS		
Section I. General	4-1-4-7	4-1
II. Theater army commander	4-8-4-13	4-4
III. Air defense brigade theater army	4-14, 4-15	4-7
IV. Theater army support command	4-16-4-19	4-7
V. U.S. Army strategic communications command (theater)	4-20-4-22	4-8
VI. Military intelligence group theater army	4-23, 4-24	4-9
VII. Civil affairs brigade theater army	4-25-4-27	4-10
VIII. The special forces group	4-28-4-30	4-10
IX. Theater army psychological operations group	4-31-4-33	4-11
X. Major subordinate commands in the combat zone	4-34, 4-35	4-12
XI. Other major units that may be assigned or attached to theater army	4-36, 4-37	4-12
CHAPTER 5. ARMY COMPONENT PLANNING	5-1-5-7	5-1
6. ARMY GROUP	6-1-6-12	6-1
7. FIELD ARMY		
Section I. General	7-1-7-4	7-1
II. Planning	7-5-7-9	7-3
III. Operational considerations	7-10-7-20	7-4
IV. Combat service support	7-21, 7-22	7-17
V. Rear area protection	7-23, 7-24	7-19
VI. Field army in stability operations	7-25-7-28	7-20
VII. Offensive operations	7-29-7-37	7-21
VIII. Defensive operations	7-38-7-47	7-24
IX. Retrograde operations	7-48-7-51	7-27
X. Supporting operations	7-52-7-55	7-28
XI. Independent and separate corps	7-56-7-58	7-30
CHAPTER 8. CORPS		
Section I. General	8-1-8-4	8-1
II. Planning	8-5-8-8	8-1
III. Operational considerations	8-9-8-21	8-3
IV. Offensive operations	8-22-8-30	8-8
V. Defensive operations	8-31-8-40	8-15 ✓
VI. Retrograde and supporting operations	8-41-8-47	8-21
APPENDIX A. REFERENCES		A-1
INDEX		INDEX-1

*This manual supersedes FM 100-15, 12 December 1963, including all changes.

CHAPTER 1

INTRODUCTION

1-1. Purpose and Scope

a. This manual provides guidance for the operation and functioning of the theater army, army group, field army, and corps. The manual treats echelons higher than theater army, to include U.S. joint commands and combined commands, only as necessary to insure understanding of the functions and duties of the commanders and staffs of those larger units.

b. The contents of this manual apply to—

(1) General war, to include consideration of the employment of and protection from nuclear, biological, and chemical (NBC) munitions; and operations in NBC environments.

(2) Limited war.

(3) Cold war, to include stability operations.

c. This manual is in consonance with the following International Standardization Agreements, which are identified by type of agreement and number at the beginning of each appropriate chapter in the manual. STANAG 2079, SEASTAG 2079, and SOLOG 48R—rear area security and rear area damage control; STANAG 2082, SEASTAG 2082, and SOLOG 49R—relief of combat troops; STANAG 2099 and SEASTAG 2099—fire coordination in support of land forces; and STANAG 2104 and SOLOG 130—friendly nuclear strike warning to armed forces operation on land.

1-2. Recommended Changes

Users of this manual should submit recommendations to improve its clarity and accuracy. They should key comments to the specific page, paragraph, and line of the text in which they recommend a change. Users should provide reasons for each comment to insure understanding and complete evaluation. Users

should forward comments directly to the Commanding General, U.S. Army Combat Developments Command Institute of Combined Arms and Support, Fort Leavenworth, Kansas 66027. Originators of proposed changes that would constitute a significant modification of approved Army doctrine may send an information copy, through command channels, to the Commanding General, U.S. Army Combat Developments Command, Fort Belvoir, Virginia 22060, to facilitate review and followup.

1-3. References

Users should employ this manual in conjunction with FM 100-5, FM 100-10, FM 100-20, FM 101-5, and FM 101-10 series, and other field manuals listed in the appendix, as appropriate. In addition, when applying material herein in joint operations, users must consult joint doctrine promulgated in JCS Pub 2 and JCS Pub 3.

1-4. Operational Environments

Conflicts in which U.S. forces may participate involve a wide variety of situations and conditions. Cold war situations and limited war can develop in any strategically significant area, and general war remains a constant threat. U.S. forces may or may not employ NBC weapons. Terrain; climate; weather; and social, political, psychological, and economic conditions differ greatly among the possible areas of conflict. Formal treaties or agreements with host countries on the status of forces may inhibit greatly the freedom of military action. Similar inhibitions may arise from foreign policy considerations and international law. Planning and execution always take into consideration these inhibiting factors. U.S. Army forces

must be able to conduct effective operations, across the entire spectrum of war in any area where conflict may occur.

1-5. Impact of NBC Operations

a. The advent of nuclear weapons and the possibility of chemical and biological (CB) operations require emphasis on flexibility and mobility of maneuver forces and the combat service support system and on minimizing vulnerability to enemy attack. Large troop concentrations and combat service support instal-

lations are profitable targets for nuclear attack. Concentration of personnel also invites chemical or biological attack. Proper planning, dispersion, and execution can reduce the effects of such attacks.

b. Effective planning for use of ground areas includes the use of vulnerability analysis as a means toward reducing the effects of hostile attacks. Dispersion is consistent with control to the degree that the situation requires and the mission permits.

CHAPTER 2

THE ARMY ROLE

2-1. The Army Role

The Army's role in the national defense establishment is to carry out missions assigned by higher authority in the following war situations:

a. General war, which is armed conflict between major powers in which the total resources of the belligerents are employed and the national survival of a major belligerent is in jeopardy. General war involves the application in a potential nuclear warfare environment, of the most modern military technology in intelligence; mobility; firepower (including nuclear, chemical, and biological weapons); command, control, and communications; and combat service support for the successful accomplishment of military objectives.

b. Limited war, which is armed conflict short of general war, exclusive of incidents, involving the overt engagement of the military forces of two or more nations. Incidents are brief clashes or other military disturbances generally of a transitory nature and not involving protracted hostilities. Limited war involves the capability to fight successfully by application of the most modern military technology in intelligence; mobility; firepower; command, control, and communications; and combat service support, for limited objectives under definitive policy limitations as to destructive power employed or the geographical area involved.

c. Cold war, which is a state of international tension, wherein political, economic, technological, sociological, psychological, paramilitary, and military measures short of overt armed conflict involving regular military forces are employed to achieve national objectives. Cold war includes the complete scope of actions, other than limited or general war, that can be used in a power struggle between contending

nations or coalitions. Included in cold war are stability operations, which involve that portion of internal defense and internal development operations and assistance that can be provided by Armed Forces to maintain, restore, or establish a climate of order within which responsible government can function effectively and without which progress cannot be achieved. The two types of stability operations wherein Army forces may be employed are—

(1) Type I, which are operations involving action by U.S. combat forces to establish, regain, or maintain control of ground areas threatened by guerrilla action, revolution, subversion, or other tactics aimed at internal seizure of power.

(2) Type II, which are operations involving U.S. advice and combat support for indigenous or allied forces engaged in establishing or maintaining control of ground areas threatened by guerrilla action, revolution, subversion, or other tactics aimed at internal seizure of power.

2-2. Performance of the Army Mission

While strategy dictates the assignment of many missions to the Services, from the Army's standpoint, the bulk of its missions requires the movement of Army forces from one point to another against resistance in the form of enemy, weather, terrain, and distance. Therefore, to perform its mission, the Army needs the means to overcome resistance in its many variations and to accomplish the required movement. To accomplish its basic combat missions, the Army needs both a tactical and a strategic capability.

2-3. Functions During Combat Operations

The five basic functions of land combat that must be discharged effectively to close with

and defeat the enemy and to gain and maintain control of the land are intelligence; mobility; firepower; command, control, and communications; and combat service support.

CHAPTER 3

ORGANIZATION AND FUNCTIONS

Section I. HIGH COMMAND

3-1. Commander in Chief

The President is the Commander in Chief of the Armed Forces of the United States.

3-2. Secretary of Defense

The Secretary of Defense, appointed by the President with the advice and consent of the Senate, is the head of the Department of Defense. The Secretary of Defense is the principal assistant to the President in all matters relating to the national defense. The Secretary of Defense authorizes, controls, and directs performance of all functions in the Department of Defense and its component agencies. The Department of Defense includes the Office of the Secretary of Defense and the Joint Chiefs of Staff (JCS), the three military departments and the Services within these departments, the unified and specified commands, and such other agencies as the Secretary of Defense establishes to meet specific requirements.

3-3. Joint Chiefs of Staff

The Joint Chiefs of Staff are the principal military advisers to the President, the National Security Council, and the Secretary of Defense. The Joint Chiefs of Staff organization consists of the Chairman, the Chiefs of Staff of the Army and of the Air Force, and the Chief of Naval Operations. The Commandant of the Marine Corps has coequal status with the members of the Joint Chiefs of Staff on mat-

ters that directly concern the Marine Corps. JCS Pub 2 and JCS Pub 4 set forth the organization and functions of the Joint Chiefs of Staff.

3-4. Secretary of the Army

The Secretary of the Army, appointed by the President with the advice and consent of the Senate, is the head of the Department of the Army. Subject to direction, authority, and control of the President, as Commander in Chief, and of the Secretary of Defense, the Secretary of the Army is responsible for and has the authority to conduct all affairs of the Army. These affairs include, but are not limited to, those necessary or appropriate for the training, operation, administration, logistic support and maintenance, welfare, preparedness, and effectiveness of the Army, including research and development. Chapter 2 provides a discussion of the primary Army roles and combat functions. AR 10-1 outlines the functions of the Department of the Army.

3-5. Chief of Staff, U.S. Army

The Chief of Staff, U.S. Army, as the principal military adviser to the Secretary of the Army, plans, develops, and executes the Army program. He is directly responsible to the Secretary of the Army for the efficiency of the Army, its state of readiness for military operations, and plans therefor.

Section II. THEATER (AREA) OF OPERATIONS

3-6. Theater (Area) of Operations (U.S. Forces)

a. A theater (area of operations is that portion of a theater of war necessary for military

operations, either offensive or defensive, pursuant to an assigned mission, and for the administration incident to such military operations. The President, through the Secretary of

Defense, with the advice of the Joint Chiefs of Staff, establishes the geographical limits of a theater (area) of operations. In large-scale operations conducted over vast geographical areas, theaters of operations are normally assigned only sufficient area to develop and serve allocated forces. Unless constricted by geographical limitations, sufficient breadth and depth are provided to secure maneuver room for all types of operations, security, and the operation of lines of communications.

b. U.S. Army publications use the term "theater of operations" for uni-Service purposes. The term "area of operations," prescribed for joint or combined operation use, is synonymous with "theater of operations."

3-7. Theater Commander (U.S. Forces)

a. The President, through the Secretary of Defense and with the advice and assistance of the Joint Chiefs of Staff, establishes unified or specified commands on an area or functional basis for the performance of military missions. He also determines the force structure of such commands. Forces assigned to a unified command normally consist of two or more Services; each Service has its own commander. When the President establishes a unified command and assigns significant U.S. Army forces to it, the commander, unified command, normally establishes a theater army (Army component). This manual considers the employment of U.S. Army forces assigned to a unified command established on an area basis (para 3-11 through 3-18).

b. The commanders of unified or specified commands are responsible to the President and the Secretary of Defense for the accomplishment of assigned military missions. Commanders of unified and specified commands exercise operational command over the forces assigned. Operational command is defined as those functions of command involving the composition of subordinate forces, the assignment of tasks, the designation of objectives, and the authoritative direction necessary to accomplish the mission. Operational command should be exercised by the use of the assigned normal organizational units through their responsible commanders or through the commanders of subor-

dinate forces established by the commander exercising operational command. It does not include such matters as administration, discipline, internal organization, and unit training, except when a subordinate commander requests assistance (JCS Pub 1 and Pub 2). The terms "operational command" and "operational control" are the same in meaning, but the term "operational command" is uniquely applied to indicate the operational control exercised by the commanders of unified and specified commands over assigned forces (JCS Pub 2). The term "operational control" will be used in all other cases.

c. The terms "commander, unified command" or "unified command commander" are used in joint operations. They are synonymous with the term "theater commander" used in U.S. Army publications for uni-Service purposes. "Theater commander" will be used throughout this manual and, where used, refers to the commander in chief of a unified command established on an area basis.

3-8. Chain of Command (U.S. Forces)

a. The chain of command for the strategic and operational direction of U.S. forces runs from the President to the Secretary of Defense and through the Joint Chiefs of Staff to the theater commanders (fig. 3-1). The President or the Secretary of Defense or the Joint Chiefs of Staff by the authority and direction of the Secretary of Defense issue orders to such commanders.

b. The chain of command for purposes other than the strategic and operational direction of unified and specified commands runs from the President to the Secretary of Defense to the Secretaries of the military departments to the Service component commanders within unified and specified commands. This chain includes the preparation of military forces and their administration and support.

c. The President exercises control and release of nuclear weapons through command channels. The President grants authority to expend or employ these weapons and transmits his decision through the military chain of command. If treaty organizations are involved, he employs both the treaty organization chain of

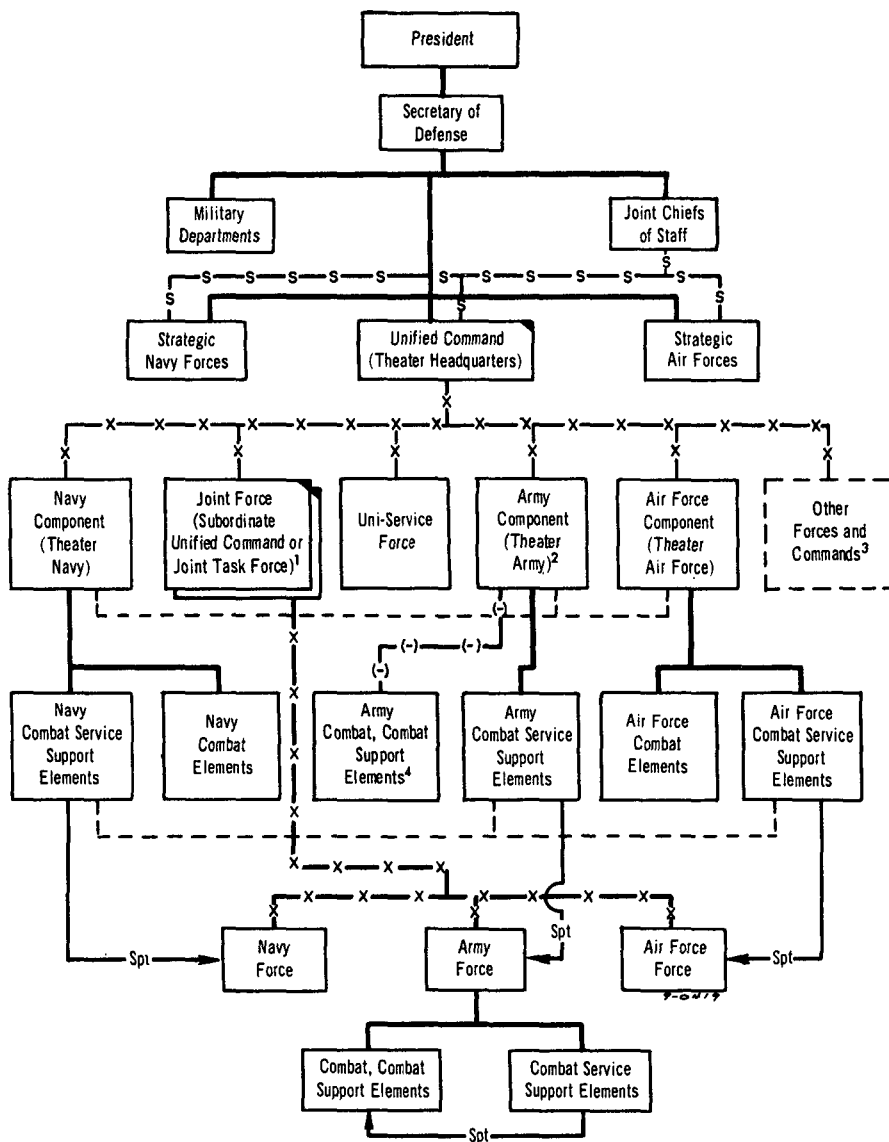

LEGEND

- Joint.
- Command.
- Direct coordination and common, joint or cross-service support.
- s s s** Strategic and operational direction.
- x x x** Operational command.
- Spt Combat service support.
- (-) (-)** Command during peacetime. Command less operational control normal during wartime.

¹The JTF exercises operational control, e.g., operational command less directive authority for logistics.

²Commands U.S. Army elements during peacetime. Normally has command less operational control of tactical elements during wartime.

³May be formed as required and as authorized.

⁴Theater commander normally exercises operational command during wartime.

Figure 3-1. Chain of command for a typical theater of operations.

command and the military chain of command.

d. Because of political considerations, nuclear weapons may be brought under the permissive action link (PAL) system employing special locks and combinations. Control of the release of PAL code words and codes is handled in a manner similar to that for the release of expenditure authority.

e. The President of the United States makes the decision to employ toxic chemical and biological (CB) weapons. Directives relating to the employment of CB munitions go to commanders through command channels.

3-9. Unity of Effort

The concept of the U.S. Military Establishment as an efficient team of ground, naval, and air forces is based on the principle that effective use of the nation's military power requires the close integration of separate Service efforts. To gain unity of effort among the Services at the national level requires the authority of the President and the Secretary of Defense exercised through the Secretaries of the military departments and the Joint Chiefs of Staff; the strategic planning and direction of the Joint Chiefs of Staff; and common-servicing, joint-servicing, and cross-servicing agree-

ments among the military components (JCS Pub 2).

3-10. U.S. Forces in Combined Operations

a. Combined operations involve the military forces of two or more allied nations acting together for the accomplishment of a single mission under a single commander. The President authorizes the participation of U.S. forces in such combined operations.

b. When operating as a part of a combined force, U.S. forces normally operate under the provisions of international treaty agreements. Generally, these agreements include provision for mutual defense. The context and provisions concerning military alliances vary according to the needs and capabilities of the nations involved.

c. International standardization agreements set forth the procedures for establishing unity of effort of combined forces. Paragraph 1-1c lists the standardization agreements that have been incorporated into this manual.

d. The U.S. component of a combined command may be a unified command, a specified command, a joint task force, or a uni-Service force.

Section III. ORGANIZATION OF A U.S. THEATER OF OPERATIONS

3-11. Territorial Organization

a. That portion of a theater of operations required for ground force operations normally is divided into a combat zone and a communications zone (COMMZ).

(1) The combat zone is that part of the theater of operations that combat forces require for operations. The combat zone includes the ground, air, and sea areas within which the commander can directly influence the progress or outcome of operations by maneuvering his ground-gaining elements or delivering firepower with the fire support systems under his control or command. Its size depends on the mission, organization, and equipment of the force involved and the nature of the country. For tactical control, the combat zone may be

divided into army group, field army, corps, and division areas. The theater commander designates the rear boundary of the combat zone; the boundary changes as the field armies move forward (fig. 3-2).

(2) The COMMZ is the rear part of a theater of operations (behind but contiguous to the combat zone) that contains the lines of communications, establishments for supply and evacuation, and other agencies required for the immediate combat service support of the field forces (fig. 3-2). The COMMZ includes sufficient area for the operation of supply, evacuation, transportation, and combat service support installations and for their defense. The COMMZ also includes any area necessary for the operation or support of Navy or Air Force elements based outside the combat zone. The

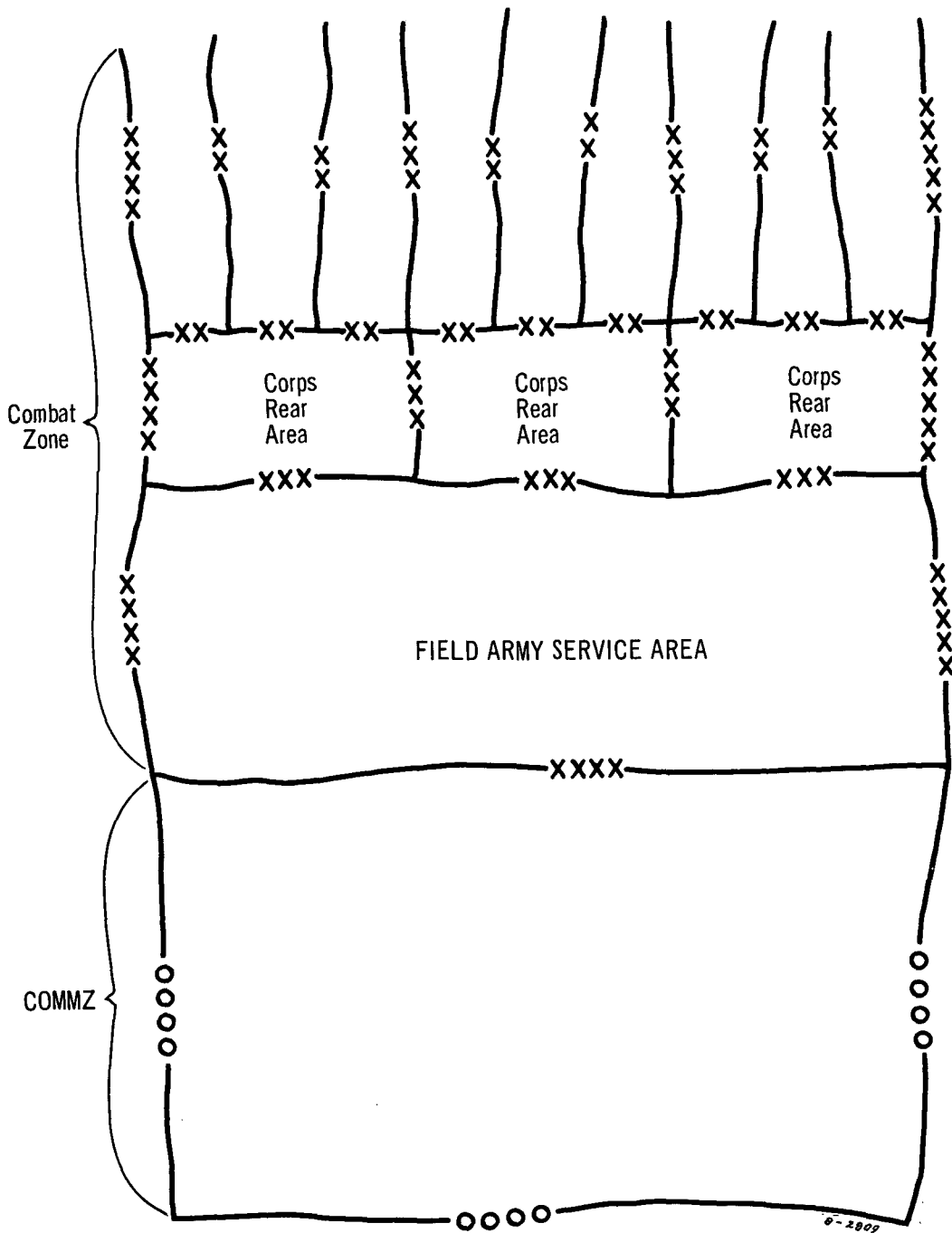
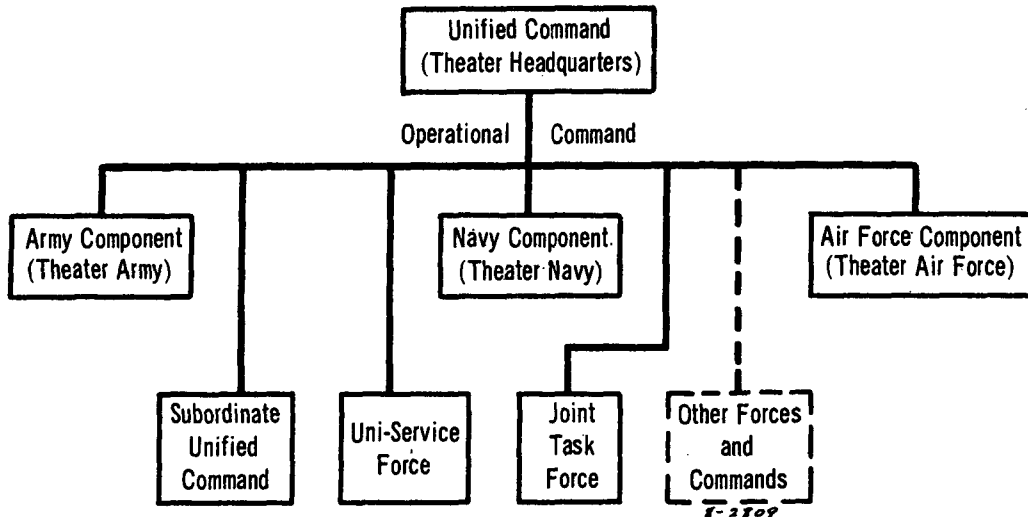

Figure 3-2. Territorial organization of a theater of operations.

rear boundary of the COMMZ is normally the rear boundary of the theater as designated by proper authority. Area responsibility for the

COMMZ is normally delegated to headquarters, theater army support command (TASCOM) (chap. 4).



NOTE: In addition to the possible command organizations shown, the unified command commander may attach elements of one force to another force.

LEGEND

--- As required and as authorized.

Figure 3-3. Organization of a unified command.

b. Territorial organization of a theater of operations varies with the type of theater, the type of forces in a theater, and the nature of the operations planned. FM 100-10 provides a more complete discussion of the territorial COMMZ. FM 54-7 provides discussion of the TASCOM organization in the COMMZ.

3-12. Command Structure, Unified Command

a. The headquarters of a U.S. theater of operations is a unified command headquarters with a joint staff. The commander organizes the unified command to perform his broad continuing mission in accordance with the capabilities, strengths, and Service identity of the component elements. Although unified commands vary in size, composition, and missions, their organizational structures are similar and are based on jointly approved doctrine. Figure 3-3 shows the major components and command relationships of a unified command. Command relationships may vary under different conditions from the unilateral scheme depicted in

figure 3-3. The theater headquarters, with the assigned forces, is a command established for the operational direction of the forces.

b. The theater commander (unified command commander) exercises operational command of assigned forces (JCS Pub 2 and fig. 3-3)—

- (1) Through the Service component commanders.
- (2) By establishing a subordinate unified command (when authorized).
- (3) By establishing a uni-Service force (when authorized).
- (4) By establishing a joint task force.
- (5) By attaching elements of one force to another force.
- (6) By directing specific operational forces which, due to the mission assigned and the urgency of the situation, must remain immediately responsive to the commander. Such specific forces must be identified by the commander and approved by the Joint Chiefs of Staff and Secretary of Defense.

c. Service component forces within a theater usually are organized unilaterally. Each com-

ponent force (Army, Navy, or Air Force) has its own organization for providing combat service support. Exceptions occur when support is otherwise provided by common-servicing, joint-servicing, or cross-servicing agreements or assignments at force, theater, department, or Department of Defense.

d. Within the framework of operational command, the commander of a unified command has authority—

(1) To deploy and plan, direct, control, and coordinate the actions of assigned forces.

(2) To establish policy for and conduct joint training exercises.

(3) To establish personnel policies required to insure uniform standards of military conduct.

(4) To establish plans, policies, and overall requirements for the intelligence activities of his command.

(5) To establish plans, policies, and overall requirements for the civil affairs activities of his command.

(6) To plan and act in coordination with host country for stability operations requirements.

(7) To exercise directive authority within his command in the field of logistics. (This authority is intended to insure effectiveness and economy of operations and to prevent or eliminate unnecessary duplication of facilities and functions among Service components. It provides for common-servicing, joint-servicing, or cross-servicing agreements or assignments. This authority includes review of budgets and requirements of the Service components of his command and coordination of priorities and programs to use supplies, facilities, and personnel effectively and to provide a balanced effort in furtherance of his assigned mission.)

(8) To direct joint activities in accordance with established joint doctrine and procedures. (Examples in the field of operations are unconventional warfare, air defense, cover and deception, intelligence and psychological operations (PSYOP); examples in the field of combat service support are activities such as those supervised by the joint medical regulating office, joint military transportation board, joint

petroleum office, and joint graves registration service.)

3-13. Component Forces

a. *Composition and Responsibilities.*

(1) A component command (Army, Navy, or Air Force) consists of the component commander and the individuals, units, detachments, organizations, and installations under his military command.

(2) Each component commander is responsible for making recommendations to the theater commander on the proper use of his component and for accomplishing such operational missions as the theater commander may assign.

(a) Additionally, the component commander is responsible within his command for—

1. Internal administration and discipline, except as may be otherwise provided.

2. Training in own-Service, doctrine, techniques, and tactical methods.

3. Service intelligence matters.

4. Combat service support functions normal to his component except as otherwise directed.

5. Preparation of contingency plans and tactical employment of the forces of his component as directed.

(b) The component commander communicates directly with his chief of Service on uni-Service matters relating to administration, personnel, training, logistics, communications, doctrine, combat developments, and other matters of internal interest. The component commander in accordance with his departmental instructions, subject to the directive authority of the theater commander, retains and exercises the operating details of the Service combat service support system.

b. *Service Component Forces.*

(1) Chapter 4 discusses the theater army commander's duties and responsibilities.

(2) The theater navy commander's responsibilities for theater navy forces generally parallel theater army commander's responsibilities as discussed in chapter 4. The theater commander is provided a Navy task organiza-

tion, consisting of combat forces with combat service support elements. The theater navy commander exercises command through the commander of the Navy combat forces. The commander bases the assignment of Navy forces on the tasks anticipated.

(3) The Air Force commander's mission is to conduct prompt, sustained, and responsive air operations in combat, including tactical air support. Tactical air support includes tactical airlift operations, close air support, interdiction, counterair, tactical air reconnaissance and supporting air operations, as required. Air Force combat support elements in the theater down to depot normally remain under command and control of the Air Force Logistics Command in continental United States (CONUS), but are immediately responsive to theater air force needs. In addition to theater air force elements, other Air Force elements used for strategic operations may be present in the theater under the operational direction of the Department of Defense or a specified command.

(a) The Air Force component commander exercises command of his forces through the Air Force component command post. He plans, controls, coordinates, and supervises activities pertaining to tactical air operations (including tactical air support) through the appropriate elements of the tactical air control system (TACS).

(b) Additionally, the Air Force component commander normally is assigned overall responsibility for theater air defense, with the mission of coordinating and integrating the entire air defense effort within the theater. Subject to the authority of the theater commander, he establishes broad policies and procedures for the employment of air defense means and the coordination of such means with the operations of other elements within the area. (Para 3-18, JCS Pub 8, and FM 44-1.)

3-14. Subordinate Unified Command

The commander of an existing unified command may establish a subordinate unified command on the recommendation of the Joint Chiefs of Staff and with the consent of the Sec-

retary of the Defense. The subordinate unified command commander has functions, authority, and responsibilities at his level similar to those of the commander of a unified command established by the President. Service component commanders of subordinate unified commands communicate directly with their respective Service component commanders of the unified command on intra-Service matters. In general, the responsibilities of component commanders of a subordinate unified command are comparable with those of the component commanders of a unified command. In a general war situation, an unconventional warfare (UW) element may be organized functionally as a subordinate unified command.

3-15. Joint Task Force

The joint task force (JTF) commander (a short-duration force composed of elements from two or more Service components established by the Secretary of Defense or by the commander of a unified command, by a specified, e.g., operational command less directive authority for logistics, command or by an existing joint task force) exercises operational control through the commanders of the Service components comprising his force. He may exercise direct command of the forces of his own Service component that comprise the joint task force. He exercises only that combat service support control or coordination necessary to the needs of his subordinate commanders. Service component commanders of a joint task force communicate directly with their respective component commanders of the unified or parent joint task force on intra-Service matters. The joint task force commander must designate Service component commanders and clearly define command responsibilities and relationships. In general, the responsibilities of component commanders of a joint task force are comparable with those of the component commanders of a unified command.

3-16. Uni-Service Force

With the approval of the Joint Chiefs of Staff, the theater commander may establish a separate uni-Service force and have the commander operate directly under him.

3-17. Other Forces and Commands

a. Specific operational forces may be organized when the mission assigned and the urgency of the situation must remain immediately responsive to the commander. Such specific forces must be identified by the commander and approved by the Joint Chiefs of Staff and the Secretary of Defense.

b. Commands may be organized functionally for certain specific types of operations with the command organization based solely on the military function regardless of geographic areas. Exemptions from control of the area commander, if applicable, are specified by the establishing authority. The theater civil affairs command, when organized, may be such a command.

3-18. Theater Civil Affairs Command

a. The theater civil affairs command may be established as required to provide centralized control of theater-wide civil affairs.

b. The theater commander is responsible for civil affairs activities throughout the theater of operations. He may delegate authority to subordinate commanders to the degree required for the accomplishment of his missions. Command over civil affairs units may be centralized or decentralized depending on the type of operation. The theater commander determines both the method of conducting the theater civil affairs operations and the organization to support that method. Basically he has three choices—

(1) To attach civil affairs units as required to each major element in the combat zone and COMMZ.

(2) To form a separate civil affairs command at the highest level and to attach all subordinate civil affairs units to that command.

(3) A combination of (1) and (2) above.

c. The scope of the theater commander's civil affairs activities varies, dependent on the de-

gree of civil affairs authority delegated to him and on the degree of control, if any, maintained by the foreign civil government over its populace and resources. This control may vary from an adequate, fully functioning civil administration to a wholly inoperative one. The theater commander's responsibilities, then, may vary from establishing proper relations between U.S. forces and the civilian population to employing U.S. forces to perform all functions of civil government. When the scope of the theater commander's civil affairs activities exceeds the capability of his civil affairs staff, he may form a functional civil affairs command to carry out his responsibilities for liaison with national government; compliance with provisions of international law, treaties, and agreements; establishment and delineation of civil affairs policies; determination of organization for conduct of civil affairs operations; and assignment of missions to major subordinate commands. This command may function under the staff supervision of the theater civil affairs officer. The civil affairs brigade is the nucleus from which the civil affairs command is formed.

d. When a civil affairs command is formed at theater, civil affairs operating units may be decentralized under operational control of major elements within the COMMZ and combat zone, decentralized in the combat zone while retaining centralized control within COMMZ, or may be fully centralized under the operational control of the civil affairs command. Because civil affairs is a function of command, placement of these units under operational control of major elements in the COMMZ and combat zone is preferred. Centralized control of civil affairs units under a civil affairs command may be desirable in a highly stabilized rear area situation where nearly normal functioning of civil authority has been restored. FM 41-10 provides detailed discussion of the civil affairs command.

Section IV. THEATER PLANNING

3-19. Information and Intelligence

a. The theater headquarters is primarily a strategic planning headquarters. To plan and prepare for the execution of assigned missions,

the theater commander must possess timely intelligence of the enemy and the area of operations to include the civil populace and related environmental factors (political, economic, so-

ciological, and psychological). During peace and war, the collection, production, and dissemination of intelligence are continuing processes.

b. The intelligence agencies of the Armed Forces and the Defense Intelligence Agency, in conjunction with the Central Intelligence Agency and other Federal agencies, produce intelligence on the capabilities, vulnerabilities, and probable courses of action of the armed forces of foreign nations to include insurgent forces that they may sponsor; and they furnish timely warning of the nature of an impending attack on the United States, its forces abroad, and/or forces of friendly foreign nations. The agencies develop descriptive studies, such as the National Intelligence Survey, of foreign countries and potential theaters of operation. These studies provide a pool of basic intelligence.

c. Peacetime intelligence programs focus on the worldwide intelligence requirement for potential wartime combat purposes.

d. In wartime, the intelligence collection effort focuses on existing and potential enemies. At theater, the commander emphasizes enemy order of battle, capabilities, deployment of enemy combat forces, materiel, and civil affairs considerations.

e. The theater commander provides overall direction and coordination of the intelligence effort of assigned forces. While the Service component commanders maintain the functions and means of executing their own intelligence functions, the theater commander may establish an intelligence organization, normally composed of intelligence elements of the Service components, under his direct command to perform theater intelligence requirements. When established, this organization also provides Service component forces with the intelligence required to supplement their own organic intelligence capability. The theater commander may delegate operational control of the theater military intelligence organization to the theater intelligence officer.

3-20. Basis

a. The National Security Council formulates

national strategy and determines national security objectives. The Department of Defense, in coordination with other executive departments, translates national strategy and objectives into national military strategy with strategic military objectives. The Joint Chiefs of Staff use these objectives and consider both the recommendations of theater commanders and the total military capabilities of the nations to arrive at a war plan that will accomplish the objectives.

b. An approved war plan, a letter of instructions, or other orders from the President, the Secretary of Defense, or the Joint Chiefs of Staff acting for, and at the direction of, the Secretary of Defense assign the theater commander's mission. The mission, usually general in nature, grants great latitude to the theater commander. Based on these broad plans, the theater commander usually formulates specific plans for operations. The basic war plan from the Joint Chiefs of Staff provides a strategic concept and forces for each component.

3-21. Scope

a. The theater commander plans as far in advance as possible and makes his operational needs known to the Department of Defense through the Joint Chiefs of Staff. The theater commander projects his planning to include the accomplishment of his mission. He may plan several campaigns concurrently, each including operations or undertakings of considerable magnitude.

b. Each plan of campaign includes—

- (1) The situation.
- (2) The mission of the force (the objective).
- (3) The course of action to accomplish the mission.
- (4) The task organization, weapons, and special equipment or materiel to be assigned or allocated to subordinate commanders.
- (5) The method of assembly of forces and locations for the campaign.
- (6) Combat service support arrangements, routes, and means of communication.
- (7) The timing and phasing of the campaign, including an estimate of the time re-

quired to accomplish all necessary measures prior to and during active operations.

(8) Security and deception measures to be employed in the campaign.

(9) Command relationship, plans of communications, and plans of electronics systems.

(10) Civil affairs aspects.

Note. Although many immediate and short-range civil affairs aspects of the campaign plan may be covered under the subjects listed in (1) through (10) above, the achievement of long-range objectives of the campaign plan requires a separate statement of objectives, plans, organization, and operations.

c. Decisive action results from clear-cut, comprehensive plans, based on full use of all available forces and means. The commander may foresee an opportunity for decisive action initially or during an operation. In either case, he needs a flexible plan so that he can exploit favorable developments.

3-22. Considerations

a. The mission, existing relationships with host country or allied nations in the objective area, enemy situation, civil populace, geography, and local resources, including existing routes and means of communication, play key roles in planning the organization and operations of theater forces. An analysis of these basic factors dictates the subdivision of the theater into separate areas and the assignment of appropriate missions to the forces allocated to each area.

b. Regardless of whether the commander prepared the plan of campaign to meet a probable or an existing situation, he considers in detail—

(1) The mission.

(2) Any political constraints or limitations imposed on his forces for the campaign.

(3) The relative capability of opposing forces.

(4) The resources required to accomplish the mission.

(5) The courses of action to accomplish the mission.

(6) The area of concentration of opposing forces.

(7) Combat service support requirements.

(8) Routes of communications.

(9) Signal communications.

(10) Psychological operations.

(11) The terrain, weather, and operational environment within the theater of operations.

In addition to assessing realistically the comparative strength of infantry, armor, artillery, nuclear weapons, and naval and air forces, he considers particularly the comparative capabilities for achieving surprise by utilizing such highly mobile elements as airborne and airmobile forces or by employing unconventional warfare, and infiltration tactics. The commander must react promptly to counter enemy employment of new forces, weapons, tactics, or techniques.

c. The following factors may play a decisive role in the employment of forces:

(1) Climate and terrain to include hydrography and major features, such as large rivers, lakes, marshes, swamps, jungles, heavily forested areas, and mountain ranges.

(2) The character and position of frontiers.

(3) Density of population, health hazards, available food resources, and potential refugee problems.

(4) Local resources to include transportation and communication facilities.

(5) The social, political, economic, and military environment including probable reaction of the population of the area; e.g., actively hostile, neutral, apathetic, friendly, or actively friendly.

d. By timely and realistic planning, the commander tries to determine the course of action that has the greatest possibility for successful accomplishment of the mission. He especially plans measures to insure security of friendly forces and to achieve surprise over the enemy either at the outbreak of hostilities or at the start of new operational phases. His plan provides for a rapid concentration of means for employment in the decisive direction. The commander also plans for contingencies to capitalize on initial success as well as to determine the required action if operations do not go as planned. The movement and employment of larger units require long-range planning and preparation. The theater commander, from the outset, visualizes the entire campaign. While

he never loses sight of the objectives of the campaign, he concurrently attempts to foresee and evaluate the situation that may develop as a result of his planned operations.

3-23. Planning Initial Operations

a. The commander's decisions and plans may require preliminary operations to acquire bases from which to conduct effective air, ground, and naval operations.

b. Theater forces do not always move directly against the enemy's main forces; they may advance toward some locality containing the essentials of the enemy's national life, forcing him to move to its defense or to abandon important territory or areas of military advantage to him.

c. The commander may select an objective that, when secured, places the enemy in an unfavorable position for decisive battle. The commander may force a situation where the terrain prevents the enemy from employing combat power in which the enemy is superior or denies the enemy room to maneuver his troops in battle. Enemy forces may be subject to de-

feat in detail if an objective requires the enemy force moving to its defense to use separate avenues of advance beyond mutual supporting distance of each other.

d. In stability operations, there is rarely a clearly defined fixed line of contact. The seizure of objectives or terrain, in the classical sense, has little or no significance. The objective becomes an orientation on the people. Therefore, timely and accurate intelligence as a basis for planning becomes increasingly important (para 2-3). These considerations are valid at all planning levels.

3-24. Effect on Component and Other Subordinate Commanders

Theater plans provide guidance in appropriate detail for the components of theater forces to conduct operations that insure unity of effort. Hence, theater plans affect the subordinate commander by directing his efforts and defining the magnitude of his task in terms of area, operational scope, and combat service support requirements.

CHAPTER 4

THEATER ARMY MISSION, ORGANIZATION, AND FUNCTIONS

Section I. GENERAL

4-1. Theater Army Mission

The theater army is the Army component of the unified command. Theater army's mission is to organize, train, and provide U.S. Army forces in support of operational requirements of the theater (unified command). The peacetime mission may include, but is not limited to, training, administration, combat service support with certain interzonal services, welfare, preparedness, and combat readiness and effectiveness of assigned Army forces and support of other agencies as directed. During wartime, the theater army's mission is primarily to provide combat service support to Army elements and to perform other missions as assigned by the theater commander. In those rare wartime instances when the theater army commander is assigned an operational tactical mission, he carries out the strategic plans and instructions of higher headquarters by issuing broad directives or letters of instructions to assigned combat forces.

4-2. Theater Army Organization

a. The U.S. theater army, when established, is a component command of the theater. Theater army does not duplicate efforts of higher and collateral headquarters or usurp functions and prerogatives of subordinate headquarters.

b. Theater army normally consists of the headquarters elements (a table of distribution and allowances (TDA) unit) necessary to provide command, a variable number of field armies or army groups, an assigned theater army support command (TASCOM), and an attached theater U.S. Army Strategic Communications Command (USASTRATCOM). Based on mission requirements, theater army

may include an Army air defense brigade or an Army air defense command, a civil affairs brigade or civil affairs command, a military intelligence (MI) group, a special forces group, a psychological operations (PSYOP) group, and other commands as required (fig. 4-1). The field army and TASCOM are on the same command level. The commanders of both organizations have the combat service support means needed to perform their mission in the combat zone and communications zone (COMMZ) respectively, subject to policy guidance and directives of the theater army commander.

4-3. Command Relationships

a. During peacetime, the theater army commander normally commands all Army troops, activities, and installations assigned to the theater. Figure 4-1 depicts limitations on the command authority of the theater army commander over those forces operating in the theater but not assigned to it. These limitations are further defined in appropriate paragraphs of this manual. The theater army commander prepares and maintains operational plans that permit the orderly transfer of operational control of the Army combat elements and other specified major units in the combat zone from the theater army commander to the theater commander as directed. During wartime, the theater commander normally withdraws from the theater army commander operational control of Army combat forces, theater army air defense forces, combat support forces and other specified units required to accomplish the theater operational mission. The theater commander, therefore, normally exercises operational command of most tactical ground forces

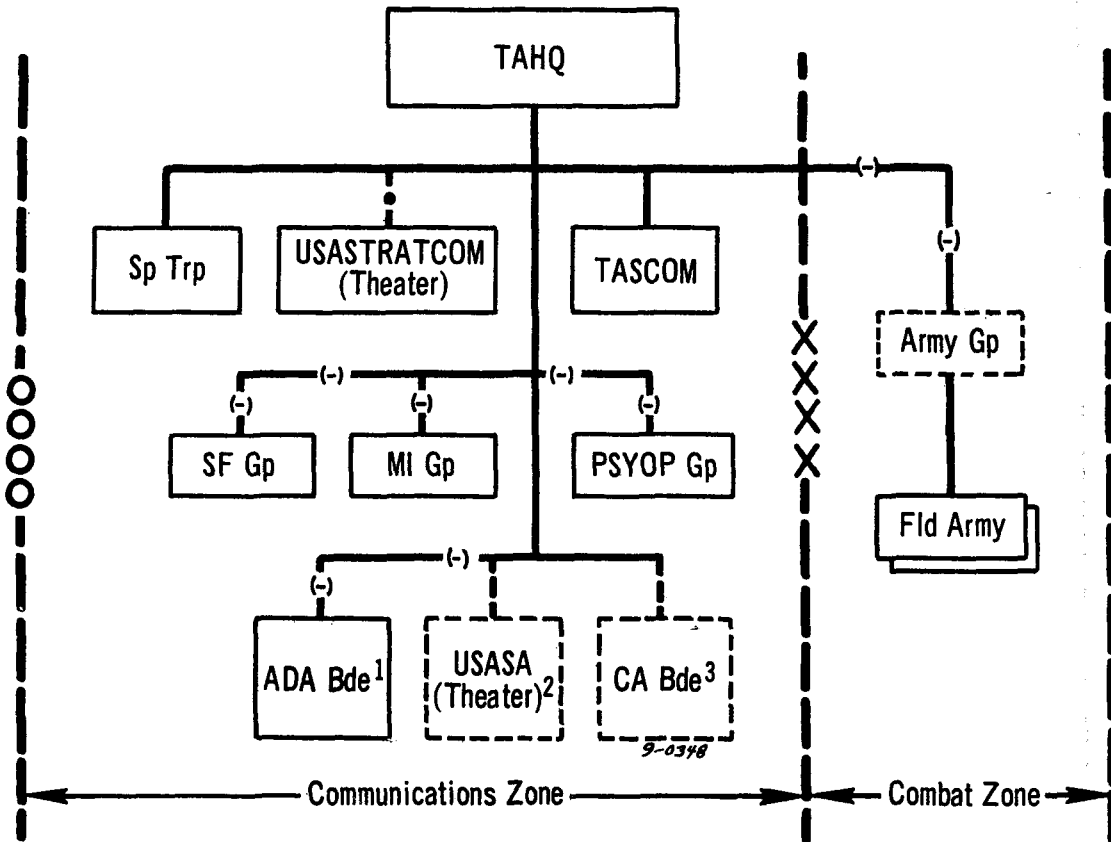

LEGEND

- As required.
- Command.
- Operational control.
- (-)— Command during peacetime. Command less operational control normal during wartime.

¹May be designated as ADA command.
²Provides support in accordance with AR 10-122.
³May be designated a CA command.

Figure 4-1. Type of theater army structure.

during wartime. The primary mission of theater army is to organize, train, and provide assigned forces in support of the theater commander's mission and to provide combat service support. Normally, in the accomplishment

of this mission, he provides the resources to the tactical forces. He provides both resources and functions to the TASCOM. Exceptionally, during wartime the theater commander may direct the theater army commander to retain

operational control of U.S. ground force operations. In this instance, the theater army commander provides strategic and tactical direction to field armies and other tactical forces.

b. The theater commander assigns geographic responsibility for the area required for conduct and support of ground force operations to the theater army commander. The theater army commander recommends to the theater commander division of this area into a combat zone and a COMMZ and assigns geographic responsibility to the army group/field army commander or commanders and TASCOM commander respectively, in accordance with joint command arrangements. These commanders are responsible for rear area protection (RAP).

4-4. Intelligence

a. The theater army commander provides overall direction and coordination of the intelligence effort of Army forces under his operational control. This effort involves collecting and processing information and disseminating intelligence and counterintelligence, including technical, scientific, and target intelligence. While he delegates the functions to his subordinate major commanders, the theater army commander, during peacetime, retains an intelligence group under his direct command to carry out theater army intelligence requirements. This organization also provides subordinate field armies and TASCOM with the intelligence required to supplement their organic intelligence capability. The theater army commander may assign operational control of the theater military intelligence organization to the theater army intelligence officer.

b. During wartime, the theater commander may require that certain elements of the theater army intelligence organization be placed under the theater control for execution of theater intelligence requirements. In these instances, the theater army commander has the task of organizing, training, and providing the required intelligence elements in support of the mission of the theater command and providing these elements with combat service support.

4-5. Combat Service Support

The theater army commander retains the over-

all control of combat service support operations to insure uniformity of the support effort within the theater. He exercises control by issuing appropriate policies, mission directives, broad planning and program guidance, allocations, and priorities for accomplishing the theater army mission. The theater army commander normally delegates authority and responsibility for executing the foregoing to the TASCOM and the field army commanders. TASCOM is responsible both for interzonal services and throughput shipments of supplies and personnel originating in the TASCOM area and for the use of allocated Air Force tactical airlift command (TAC) and military airlift command (MAC) aircraft. Close liaison is necessary between the TASCOM and the field army support command (FASCOM), their higher headquarters, and their subordinate functional activities and units. The theater army commander provides for the exercise of technical supervision (including technical inspections and instructions) by combat service support commanders applicable to the force as a whole (supported and supporting forces) and is responsible for materiel readiness of Army equipment.

4-6. Theater Army in Stability Operations

a. The stability operations mission of theater army is to provide assistance, as specified by the theater commander, to requesting host countries in order to prevent or defeat insurgency. All forces assigned to the theater army components of a unified command are potential stability operations forces. Theater army organizations and units have a capability to perform in-country surveys; to plan for and advise, train, and supervise host country forces in the performance of the combat, combat support, and combat service support aspects of internal defense and internal development programs; and to deploy combat service support, combat support, and combat forces to cope with deteriorating internal defense situations. U.S. Army forces serve under the guidance of the Chief, U.S. Country Team, and their efforts are integrated with those of other U.S. Government agencies and Services. U.S. forces' support is normally provided through area coordination centers established at intermediate

(regional, provincial, and district) and local levels. These combined civil/military headquarters perform a twofold mission: they provide integrated planning, coordination, and direction of all internal defense and internal development efforts and insure immediate, coordinated response to operational requirements.

b. FM 100-20 provides discussion on internal

defense and internal development. FM 31-23 contains a discussion of stability operations.

4-7. Tactical Operations Center

Normally, echelons above field army do not have a tactical operations center because they are engaged in long-range planning and are not deeply engaged in day-to-day operations.

Section II. THEATER ARMY COMMANDER

4-8. Command

a. Except for the theater commander and members of his joint staff, the senior U.S. Army officer assigned to the unified command and qualified for command by Army regulations is normally the theater army commander. Only in an emergency and on a temporary basis is the theater army commander also the commander of the unified command. When the commander exercises dual command, he uses separate and distinct staffs to exercise the functions of operational command and component command.

b. The theater army commander, during peacetime, normally commands all U.S. Army forces assigned to theater; however, during wartime, he normally has command less operational control of most tactical ground forces, theater army air defense forces, and other specified forces. The theater army commander has authority commensurate with his assigned responsibilities. When the theater army performs the TASCOM functions (para 4-8e and 4-13) or in those cases where a theater consists of a number of subordinate unified commands each with its own support command, the theater army staff may centrally control the operating functions of inventory control, personnel and maintenance management, movement control, and automatic data processing (ADP) procedures.

c. The theater army commander normally retains under his command only the forces necessary to perform theater-wide sensitive and specialized functions such as technical intelligence production and combat service support. The theater army commander analyzes his mission, establishes the theater army structure determined to be most efficient and effective, and al-

locates tasks and available resources among the various subordinate headquarters and commands. He assigns all normal operating means to the commanders of army group/field army and to the TASCOM. The theater army commander is primarily a supervisor, a planner, and coordinator, who provides centralized direction and doctrine for the decentralized execution of his assigned missions.

d. In a theater of operations where U.S. Army units are part of a combined force, the strategic and tactical direction of U.S. Army groups and field armies normally originates from headquarters other than U.S. theater army. The U.S. theater army headquarters is primarily an administrative headquarters providing centralized direction, plans, and coordination of the combat service support of U.S. Army forces.

e. Normally theater army has no assigned wartime operational mission in a theater of operations, and it may be directed to eliminate the TASCOM and assume the responsibility for direction and control of the area and combat service support functions of the subordinate TASCOM commands. He makes minor modifications to staff sections to provide for increased activity in detailed planning and policy guidance, specific quantity allocations, and increased coordination with the supported forces.

4-9. Relationship With the Theater Commander

a. The U.S. theater army commander makes recommendations to the theater commander for the employment of the Army component. He plans for the wartime release of selected tactical units to the theater commander and ex-

ecutes such missions as the theater commander assigns.

b. The U.S. theater army commander is responsible within his command, as directed, for—

(1) Internal administration and discipline, except where these functions are of joint interest or where the responsibilities of the theater commander are affected.

(2) Training in Army doctrine, techniques, and tactics.

(3) Combat service support functions normal to the Army component, except as otherwise directed by higher authority.

(4) Employment of the forces under his command.

(5) Army intelligence matters.

(6) PSYOP matters.

(7) Prisoner of war (PW) policy and planning matters.

(8) Civil affairs.

(9) Army air defense as part of theater air defense.

(10) Special forces operations.

(11) Special ammunition support.

c. The U.S. theater army commander operates Army combat service support systems in accordance with Department of the Army instructions, subject to the directive authority of the theater commander. The theater commander's directive authority should insure effectiveness and economy of operation and prevent unnecessary duplication of facilities and overlapping of functions among the Service components. (See para 3-12d(7).) The theater commander's authority in the area of combat service support extends to the coordination of—

(1) Acquisition, storage, movement, distribution, maintenance, evacuation, and disposition of materiel.

(2) Movement and evacuation of personnel.

(3) Acquisition or construction, maintenance, operation, and disposition of facilities.

(4) Acquisition or furnishing of services.

4-10. Relationship With the Chief of Staff, U.S. Army

The U.S. theater army commander communi-

cates directly with the Chief of Staff, U.S. Army, on uni-Service matters relating to administration, personnel, training, logistics, communications, doctrine, and combat developments and on intelligence matters primarily of Army interest. The Chief of Staff, U.S. Army, appoints the theater Army commander.

4-11. Relationship With Collateral Commands

The theater army commander coordinates his operations with those of theater navy, theater air force, and other major subordinate commands of the theater (fig. 3-1 and 3-3). In a joint task force, the theater army commander provides combat service support to both the U.S. Army component of the joint task force and its other components as the theater commander directs.

4-12. Theater Army Staff

a. The theater army headquarters staff assists the commander in accomplishing his mission. It is organized to permit fragmentation of the headquarters and operation in separate locations. Normally staff activities concern policy planning and coordination rather than direction of operations. Similar functions are grouped and assigned to a staff section to permit organizing the headquarters into functional units and to standardize staff officer training. Normally, the expansion of staff sections is sufficient to cope with the enlarged activity occasioned by the increase of subordinate major commands, assigned mission, and the variation of conflict missions. Staff officers work in close coordination with their counterparts in the other Services and with the theater headquarters staff.

b. Other staff section functions, e.g., information officer, inspector general, and staff judge advocate, not integrated into the general staff, are performed either by separate staff sections or by administrative and technical service personnel assigned to the commander's personal staff. The theater army staff officers rarely perform operational functions; their primary concern is planning and policy formulation (fig. 4-2). FM 101-5 provides a discussion on staff officer functions.

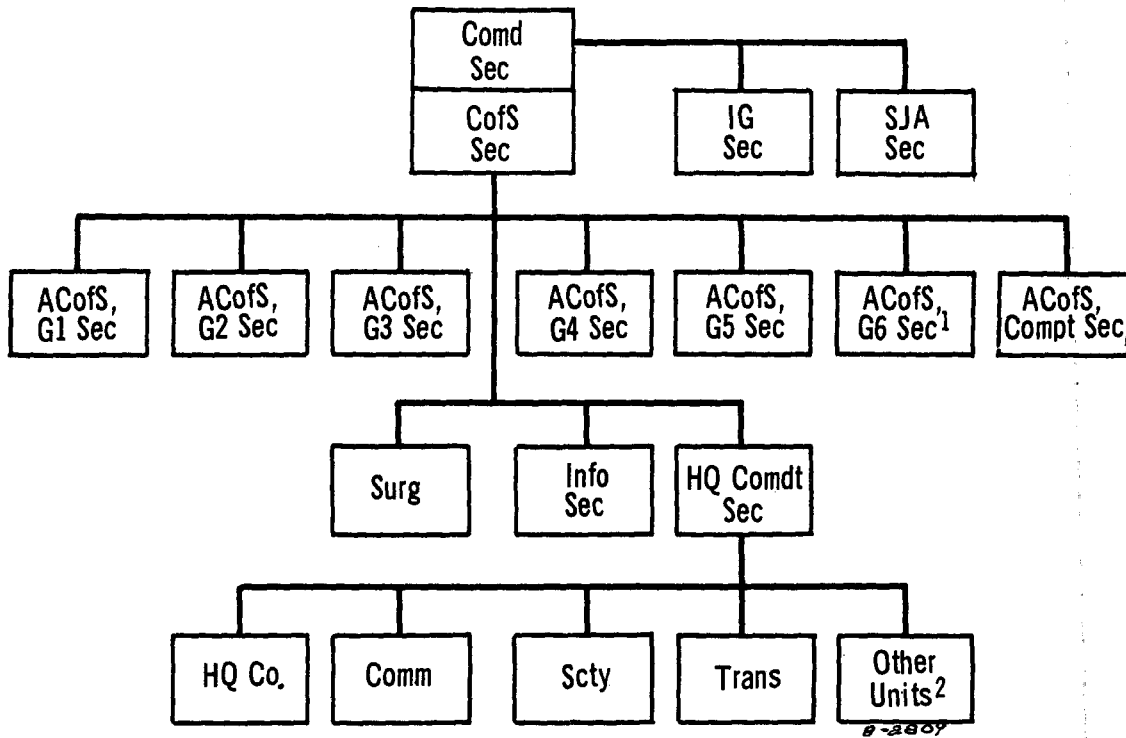

¹Communications-electronics officer. Also commands USASTRATCOM (Theater).

²As required.

Figure 4-2. Theater army headquarters.

4-13. Staff Impact When Theater Army Headquarters Assumes HQ TASCOM Functions

a. In wartime when the theater army headquarters normally has no operational mission, TASCOM headquarters is not needed and theater army headquarters may assume the functions of planning, directing, and coordinating combat service support. Normally, the theater army staff coordinates combat service support activities to insure support of the combat forces. Theater army headquarters provides procedures and guidance for establishment of appropriate channels of communications between the combat forces and combat service support activities. For routine combat service support operations, the subordinate operating commands of TASCOM maintain direct and

continuous contact with appropriate CONUS agencies and with the FASCOM. Theater army headquarters' assumption of direction of the combat service support mission does not affect established working relationships between these headquarters.

b. Theater army headquarters' assumption of direction of the combat service support mission requires increased activity in detailed planning and policy guidance, specific quantity allocations, and increased coordination with the supported forces.

(1) A reorganization of the appropriate staff sections must establish functional subdivisions to conform to the activities of the subordinate commands. If required, the commander normally delegates technical or opera-

tional control of subordinate commands' operations to appropriate staff officers to decrease the theater army commander's span of control.

(2) Widespread use of the principle of management by exception, using summary reports and ADP printouts indicating trends or

situations of the combat service support, increases the need for staff coordination.

(3) Assumption of geographical responsibility for the COMMZ requires staff emphasis on civil affairs and rear area protection (rear area security and area damage control) and results in larger G2, G3, G4, and G5 sections.

Section III. AIR DEFENSE BRIGADE, THEATER ARMY

4-14. General

The theater army commander is responsible to the theater commander for the employment of Army air defense resources. Normally, control of air defense elements in the army group or field army areas is delegated to the army group or field army commander. Normally, the Air Force commander directs the theater air defense effort through the theater air defense organization. The theater army commander's responsibilities include—

a. Furnishing the theater commander with theater army air defense requirements in priority.

b. Allocating, organizing, and employing Army air defense means.

c. Prescribing unit training and operating procedures and furnishing combat service support.

d. Planning for, coordinating, and staging additional Army air defense forces into the theater.

4-15. Organization and Mission

a. In the combat zone, the regional air defense commander normally delegates authority to the field army commander for the control

and operational employment of Army air defense means that are organic, are attached, or support the field army.

b. In the COMMZ, the air defense operational requirements, available units, and area organization govern the organization for army air defense. Normally, the major U.S. Army air defense unit in the COMMZ, is the U.S. Army ADA brigade, a subordinate command of theater army (fig. 4-1). Exceptionally, an air defense command, theater army may be formed when administrative and logistic requirements exceed the capability of a brigade headquarters. The theater army commander's responsibility for these units normally is confined to command less operational control. The theater army headquarters staff is responsible for broad policy guidance concerning air defense priorities and allocation of resources. The air defense brigade commander has normal command responsibilities for training, administration, and combat service support of his forces and for operational missions as assigned. The TASCOM is responsible for combat service support in response to the theater army air defense brigade commander's established requirements.

Section IV. THEATER ARMY SUPPORT COMMAND

4-16. Mission

The TASCOM provides combat service support to Army forces in a theater of operations and to other forces as designated. Services include general support to the field army, direct and general support in the COMMZ, responsibility for rear area protection within the COMMZ, AND STABILITY OPERATIONS REQUIREMENTS. In addition, the theater army com-

mander assigns to TASCOM responsibility for area emergency warning in the COMMZ.

4-17. Basis

a. TASCOM, a major subordinate command of theater army, is assigned on the basis of one per theater army.

b. The self-sustaining capability of TASCOM subordinate units permits them to oper-

ate directly under theater army if theater army has no operational mission and the TASCOM headquarters is not provided.

4-18. Functions

a. TASCOM combat service support functions include those services defined in AR 320-5. Theater army headquarters provides TASCOM necessary policies, priorities, allocations, directives, and guidance to permit conduct of theater activities in the execution of assigned missions. The TASCOM commander, when delegated authority, may issue technical instructions to supported units of theater army and may conduct technical inspections thereof. He may further delegate authority to major subordinate commanders to perform these technical inspections and inspection functions.

b. The theater army commander assigns the

TASCOM commander territorial responsibility for the COMMZ. The TASCOM commander further assigns the area responsibilities to the commander, area support command (ASCOM).

c. FM 54-7 and FM 100-10 provide detailed discussions of the TASCOM.

4-19. Organization

A TASCOM normally is composed of the following major subordinate units:

- a. Headquarters, TASCOM.
- b. Personnel command (PERSCOM).
- c. Supply and maintenance command (SMCOM).
- d. Engineer command (ENCOM).
- e. Transportation command (TRANSCOM).
- f. Medical command (MEDCOM).
- g. ASCOM.

Section V. U.S. ARMY STRATEGIC COMMUNICATIONS COMMAND (THEATER)

4-20. General

The theater army commander provides signal communications for Army elements and other specified activities within the theater of operations. The theater army commander executes his communication responsibilities in the COMMZ by means of the theater army communications system (TACS). The USASTRATCOM (Theater) establishes and operates the TACS, which extends forward from the COMMZ rear boundary to the combat zone and establishes two access points for connection into the field army area communications system. The field army commander normally has the responsibility and resources for communications within the combat zone (para 7-20).

4-21. Mission

USASTRATCOM's mission is to command assigned and attached signal units; to formulate and implement plans, policies, and procedures for the installation, operation, maintenance, and management of the TACS; and to furnish signal support for special purpose communications systems.

4-22. Organization and Functions

a. The USASTRATCOM (Theater) is under the operational control of theater army headquarters. The commander of USASTRATCOM (Theater) also serves as the theater army communications-electronics staff officer (ACofS, G6).

b. The USASTRATCOM (Theater) consists of a headquarters and a variable number of signal companies, battalions, and groups. The numbers and types of units depend on the mission and size of the theater of operations. FM 11-23 and FM 101-10-2 provide detailed descriptions and capabilities of signal units comprising the USASTRATCOM (Theater).

c. USASTRATCOM (Theater) provides, on an attachment basis, the signal operation companies, large/medium/small headquarters, to provide the following communication support:

(1) Communications facilities, photographic, and cryptologic support to major command headquarters and other designated headquarters, installations, and units within the COMMZ.

(2) Communications for pipeline, railway, highway, and inland waterway systems within the COMMZ and any of these same systems that are interzonal (COMMZ and combat zone).

(3) Communications support to air defense units and installations not otherwise provided support.

(4) Communications support on independent operations to major maneuver elements requiring supplement to organic communications capability.

d. The USASTRATCOM (Theater), through operation of the TACS, interconnects the or-

ganic tactical communication systems of the major theater army maneuver force (army group/field army, independent corps, or division) to the theater army headquarters and the defense communications system (DCS) achieving an integrated worldwide communication system. FM 11-23 and FM 100-10 provide detailed discussions of the TACS.

e. USASTRATCOM (Theater) receives direct and general service support from the TASCOM in accordance with the support agreement established between the USAS-TRATCOM and theater army commanders.

Section VI. MILITARY INTELLIGENCE GROUP, THEATER ARMY

4-23. General

The MI group supporting headquarters, theater army provides intelligence and intelligence specialist support services that are beyond the organic capability of theater army subordinate commands or that can be centralized more effectively and efficiently. Subordinate theater army commands retain intelligence responsibilities and resources that are essential to their mission and whose assignment to the theater army reduce response time to a degree constituting an unacceptable risk. FM 30-9 provides the basic reference for the MI group and operations.

4-24. Organization and Functions

a. MI group theater army provides personnel support to theater army for collection and processing of intelligence information. The group is assigned to theater army headquarters and receives staff supervision from the theater army intelligence officer.

b. The theater army headquarters (TAHQ) staff support section provides augmentation to the theater army G2 in the form of MI intelligence staff and production specialists, as required. This section may also provide army intelligence staff personnel to augment the intelligence staff section at theater. The TAHQ support element is normally constructed through the use of MI cellular teams and personnel of the TOE 30-500 and TOE 30-600 series based

on the current and anticipated requirements of the command. Examples of MI specialists who may be included in this section are strategic intelligence and order of battle production specialists; censorship personnel; and intelligence, counter-intelligence, and technical intelligence staff personnel. These personnel are employed directly within the theater army ACofS, intelligence, staff sections.

c. The relationship to other theater army and component commands follows:

(1) The MI group, theater army, operates in direct support of headquarters, theater army, and in general support of the MI battalions assigned to the field army and the MI group, security, ASCOM, TASCOM. If theater establishes joint facilities, the MI group can provide the Army element thereof.

(2) The MI group, theater army, coordinates closely with comparable intelligence units of other Service component commands to provide for the timely exchange of intelligence information, consolidation of appropriate operations, and the elimination of conflicts and duplication.

(3) The MI group, security, ASCOM/TASCOM, provides MI specialist support for TASCOM units and all Army units and installations, including the theater army headquarters in the TASCOM area. The group is responsible for conducting personnel security investigations of Army personnel and for con-

ducting counterintelligence operations in support of the ASCOM rear security mission.

(4) The MI units assigned to theater army, field army, and TASCOM support those commands in the exercise of their command in-

telligence responsibilities. Although the three echelons establish working level coordination for many of their activities, they operate under the staff supervision of their respective command intelligence officers.

Section VII. CIVIL AFFAIRS BRIGADE, THEATER ARMY

4-25. General

The theater commander may delegate civil affairs authority for the theater to the theater army commander. Therefore, the theater army commander determines the method of conducting theater civil affairs operations and the organization to support that method as discussed in paragraph 3-18. Delegation of theater civil affairs authority to the theater army commander is unlikely, however, because he is not normally in the wartime operational chain of command between the theater commander and the tactical forces of the combat zone. The theater commander may delegate civil affairs authority for the combat zone to the field army commander or commanders and for the COMMZ to the theater army commander. Therefore, the theater army commander may retain the civil affairs authority for COMMZ or further delegate it to TASCOM headquarters. If the theater army commander retains civil affairs authority, the civil affairs brigade is a major subordinate command of theater army. If he delegates civil affairs authority to TASCOM, he also assigns the civil affairs brigade to TASCOM. If delegated civil affairs authority, the TASCOM commander normally further delegates civil affairs authority to the

ASCOM commander in which case he also assigns or attaches necessary civil affairs units (may be the brigade) to the ASCOM.

4-26. Mission

The Civil Affairs Brigade assists the parent headquarters in planning, coordinating, directing, and supervising civil affairs operations; and it provides civil affairs elements to subordinate commands to assist in executing their civil affairs responsibilities.

4-27. Joint and Combined Operations

a. A U.S. Army civil affairs organization may be required to support U.S. Navy, U.S. Air Force, joint task force, or combined command operations or to support a civilian agency having primary political and economic responsibilities in the area. In joint operations, the U.S. Army civil affairs brigade may be placed under the operational control of the senior military commander or directly subordinate to the senior U.S. Army commander.

b. In combined operations, the mission, responsibilities, and authority of the major U.S. Army civil affairs command within the area of operations stem from U.S. and allied policy and the combined command organization.

Section VIII. THE SPECIAL FORCES GROUP

4-28. General

The theater army organization normally will include a U.S. Army Special Forces group. When a theater unconventional command is established, this group functions as the Army component of the command. The special forces group is the major table of organization and equipment (TOE) unit within the U.S. Army Special Forces which provides command, control, administration, and support for assigned operational detachments. The special forces

group can assume strategic or tactical missions and provide flexible response. It can undertake a variety of tasks and missions, in many modes and configurations, under circumstances and in environments not customarily envisioned for regular forces, and, most importantly, in all levels of conflict. U.S. Army Special Forces' participation in operations may be either in a primary role or in a supporting role in conjunction with other forces or agencies. Deployment for operations may involve

only selected individuals or detachments with specific capabilities, or it may require one or more special forces groups. The special forces group establishes the special forces operational base (SFOB) in friendly territory as required. FM 31-21 and FM 31-21A provide discussions of special forces operations.

4-29. Mission

As a multipurpose force, the U.S. Army Special Forces group must be prepared for commitment to any mission within its capability. These missions range from the conduct of unconventional warfare to advisory/training duties in preventive insurgency circumstances. Mission possibilities are a direct function of the capabilities of special forces.

4-30. Capabilities

Special forces possess specific capabilities—

- a. To infiltrate and exfiltrate specified areas by air, land, or sea.
- b. To survive and operate in remote areas and hostile environments for long periods with minimum external direction and support.
- c. To plan and conduct military operations including, but not restricted—
 - (1) To developing, organizing, equipping,

training, and directing indigenous forces in guerrilla warfare.

(2) To participating in evasion and escape operations or supporting them.

(3) To participating in other unconventional warfare missions, either unilaterally or in conjunction with indigenous resistance forces.

(4) To training, advising, and assisting indigenous military or paramilitary forces, to include operational, logistic, and fiscal support.

(5) To participating in intelligence, reconnaissance, and surveillance missions in remote or hostile areas, to include long-range patrols, military free-fall parachute operations, and underwater operations.

(6) To attacking critical targets in remote or urban areas.

(7) To recovering friendly personnel from remote or urban areas.

(8) To conducting training for U.S. personnel in special forces operational techniques that have utility in conventional force operations.

(9) To planning assistance to other forces and agencies in connection with special forces activities.

Section IX. THEATER ARMY PSYCHOLOGICAL OPERATIONS GROUP

4-31. General

The theater army commander implements PSYOP through the supporting PSYOP group. The group formulates plans in conformity with the theater commander's guidance.

4-32. Mission

The U.S. Army PSYOP mission is to assist the commander in his operations by influencing the behavior of selected groups.

4-33. Capabilities and Functions

a. The PSYOP organization provides for support to the theater army, field army, and other commands or agencies of the government within the theater as required. The team AC (group) is the largest of the three command and control units and is a flexible organization designed to provide commanders at theater with personnel capable of planning or as-

sisting in the formulation of policy for PSYOP. The team AB (battalion) is designed for employment at field army; and it can aid the commander by implementing policy, planning, programing, and producing propaganda. The team AA (company) is a small command and control unit and is designed to provide personnel for support of army PSYOP activities at corps and division or in other areas when a small composite unit is employed.

b. Operational teams are assigned to the command and control teams at each level in the numbers and the types desired according to operational requirements. The number and the type of operational teams depend on the specific situation. The cellular structure of the PSYOP unit provides a flexibility for adding a mix of teams that would permit it to accomplish an assigned mission in any given situation.

Section X. MAJOR SUBORDINATE COMMANDS IN THE COMBAT ZONE

4-34. Army Group

a. The army group, a major subordinate command of theater army, normally is established only in a large theater of operations where the ground force comprises two or more field armies.

b. In a theater of operations in which U.S. Army units are a part of a joint or combined force, the army group normally functions under the operational direction of a superior unified or combined command headquarters. Exceptionally, the army group may function under the operational direction of theater army.

c. Chapter 6 provides discussion of army group organization and functions in detail.

4-35. Field Army or Independent Corps

a. If the theater army commander does not establish an army group, he may establish a

field army or an independent corps as a major subordinate command of theater army.

b. In small theaters, the field army or independent corps may be the Army component of the theater. In such cases, the concepts of organization, mission, and functions outlined in this chapter apply to the smaller theater, modified as necessary to satisfy the requirements of a particular theater. When a field army or corps is the major Army component of a theater, its normal preoccupations with the combat mission may prevent the assignment of theater army responsibilities. In that case, the theater commander establishes a small theater army headquarters. When the field army or corps has theater army responsibilities, the theater headquarters may exercise tactical as well as strategic direction.

c. Chapter 7 provides discussion of the organizations, functions, and operations of the field army.

Section XI. OTHER MAJOR UNITS THAT MAY BE ASSIGNED OR ATTACHED TO THEATER ARMY

4-36. General

Other major units may be assigned or attached to theater army as required to accomplish the commander's mission. Requirements will vary based on the commander's mission, the existing condition within the spectrum of war, the geographical area assigned to theater army, and existing unique combat service support requirements.

4-37. U.S. Army Security Agency Units

Normally, a headquarters, U.S. Army Security Agency (USASA) (theater army) is estab-

lished in response to headquarters, theater army requirements. Likewise, a headquarters, USASA (army group), is established in response to headquarters, army group, requirements. The USASA (theater army) and the USASA (army group) are organized under TDA and attached as specified by AR 10-122. Their composition varies with mission and support command requirements. A USASA group (field army) is organized under TOE and attached to the field army that it supports. FM 32-10 provides details.

CHAPTER 5

ARMY COMPONENT PLANNING

5-1. General

a. Army component planning supports the theater commander's plans. Consequently, much of the discussion in chapter 3 relates to Army component planning and is necessary guidance in such planning.

b. This chapter outlines the planning and operational responsibilities of Army component forces in a U.S. theater of operations.

(1) In peacetime, the theater army commander normally is responsible for command and operational control of all theater army forces.

(2) In wartime, the responsibility for tactical planning and operations of forces in the combat zone normally is retained by the theater commander. However, he may delegate this responsibility to the commander of a subordinate unified command or to the senior commander of Army combat forces in the combat zone. Exceptionally, the theater commander may vest this responsibility for tactical control of Army forces in the theater army commander.

c. The planning discussed in this chapter is divided and often parallel between the theater army (Army component) commander and the commander who is assigned control of Army forces in the combat zone, hereafter referred to as commander, Army combat forces.

(1) The theater army commander is responsible to the theater commander for planning and operations within the COMMZ and for coordinating plans and operations to provide combat service support to Army forces in the theater.

(2) The commander, Army combat forces, is the tactical commander of U.S. Army elements in the combat zone, except in those rare

instances when the theater commander causes the theater army commander to retain this responsibility. The commander, Army combat forces, is responsible for tactical operations, planning, and the coordination required to accomplish his mission. Coordination between commanders of Army combat forces and theater army will be accomplished as directed by the theater commander.

5-2. Information and Intelligence

a. Higher headquarters keeps the field commanders advised of pertinent political, economic, and military information of potential enemies to include ground, air, and naval order of battle; enemy capabilities; and probable courses of action. Field commanders require such information and intelligence to insure the constant preparation of forces under their command to cope successfully with changes in the strategic and tactical situation. All intelligence agencies focus on obtaining early warning of impending hostile action. Commanders of Army combat forces and theater army base their plans on intelligence that both higher headquarters and intelligence agencies within their respective forces provide.

b. In wartime, the field intelligence agencies' missions are primarily to obtain complete information of the hostile forces confronting them or those capable of intervening in current or planned operations. They must also obtain information concerning the weather, the terrain and the population and its institutions in areas of actual and projected operations. Correct evaluation and interpretation of this information and its integration with that provided by the higher headquarters assist in providing a sound basis for planning and executing theater army operations.

5-3. Basis of Planning

The theater commander assigns missions, which are a part of the theater campaign plan, to the theater army commander, and to the commander, Army combat forces, when the latter has control of forces in the combat zone.

5-4. Estimates

a. The commander, Army combat forces, based on assigned theater missions, prepares estimates to determine the best course of action for conducting the campaign and accomplishing each specific mission that forms a part of the campaign. Having determined the best course of action, the commander, Army combat forces, prepares an analysis of the forces, the materiel, and the support required to carry it out. This most important analysis of requirements is coordinated with the theater army (Army component) commander, who utilizes the analysis in determining total theater requirements for Army resources. These requirements will be the bases for determining the allocation of Army forces and resources to the theater by the Department of Defense through the Joint Chiefs of Staff (JCS) and, in turn, by the Department of the Army.

b. When the estimated requirements exceed the allocations, the theater army (Army component) commander may recommend to the theater commander—

(1) A change in the theater army troop, special weapon, and combat service support allocations.

(2) A change in the theater army mission with respect to scope or time phasing or objectives.

(3) The acceptance of a greater calculated risk on certain missions.

(4) A change in the type and the amount of support that theater or strategic Navy and Air Force forces render to Army forces.

(5) A change in support that theater army renders to theater navy or theater air force forces.

5-5. Scope of Planning

a. The commanders of army combat forces

and theater army are primarily supervisors, planners, and coordinators, who decentralize the more detailed aspects of combat and combat service support operations to their subordinate commanders.

b. The commanders of Army combat forces and theater army base their planning on the theater strategic concept. These commanders must be aware of the theater commander's strategic concept for the entire military campaign and also the strategic objectives.

c. Theater army headquarters' planning, like theater headquarters' planning, basically deals with the strategy of the overall military plan. The commander, Army combat force, coordinates his plan for ground combat with the other Services before publication to subordinate echelons. The commanders of Army combat forces and theater army analyze the overall mission and visualize the major tactical and logistics operations necessary to accomplish the assigned mission. They relate what is strategically desirable to what is tactically and logistically possible in terms of the capabilities of field armies and their required support.

5-6. Operational Directives

As the time approaches to issue directives for an operation, the commanders of Army combat forces and theater army review the original estimates for the operation and the details of the plans and prepare and issue revised directives to their respective subordinate commanders.

5-7. Coordination With Other Commands

a. The theater army commander maintains close liaison with the theater navy and the theater air force commanders. The theater army commander coordinates combat service support plans and other operational plans as required with those of the other Service components in the theater before he issues orders. The commander, Army combat force, maintains close liaison with operational Air Force and Navy elements.

b. Chapters 6, 7, and 8 cover planning at army group, field army, and corps respectively.

CHAPTER 6

ARMY GROUP

(STANAG 2099 and SEASTAG 2099)

6-1. General

This chapter pertains to a U.S. Army group composed of U.S. Army units operating in a theater. Responsibility for directing U.S. ground force operations may be retained by the theater commander or delegated to the commander of a subordinate unified command. In rare instances, this responsibility may be delegated to the theater army commander. The commander exercising operational control of Army forces in the combat zone is herein called the commander, Army combat forces (para 5-1). The principles discussed herein also apply to an army group containing allied units or operating under the direction of a combined force headquarters.

6-2. Organization

a. The army group consists of a headquarters and those units necessary for command, communications, and administrative support; two or more field armies; and, in some situations, separate corps and/or separate divisions (fig. 6-1).

b. The army group headquarters plans and conducts tactical operations. It performs the staff action necessary to translate the operational directives of the commander, Army combat forces, into definitive tactical actions for subordinate unit execution. The army group headquarters is primarily a tactical echelon of command with limited combat service support responsibilities.

c. The commander, Army combat forces, determines the composition and the strength of the forces required by the army group based on his plans for conducting the campaign and accomplishing each of the basic missions that

make up the campaign, the mission assigned to the army group, the characteristics of the area of operations and enemy capabilities, and probable courses of action.

6-3. Command

a. The Department of the Army or the Army component commanders designates the army group commander.

b. The army group commander normally has territorial responsibility for the combat zone. This responsibility includes rear area protection, highway management, traffic control, air defense, and civil affairs coordination. The army group commander, in turn, normally assigns this territorial responsibility to the field army commanders.

6-4. Army Group Headquarters

a. Army group headquarters is a table of distribution and allowances (TDA) unit, organized for a specific operation or campaign.

b. Normally the headquarters of an army group is echeloned; it has a relatively small rear echelon that is concerned primarily with providing administrative support to the main echelon. The army group commander may organize a tactical command post based on the immediacy of tactical requirements and the adequacy of the communication system. Its location will be wherever the army group commander directs.

c. Command communications links between army group headquarters and its major subordinate headquarters are provided by the theater army communications system (TACS). Internal communications for army group headquarters are provided by the signal medium headquarters operations company.

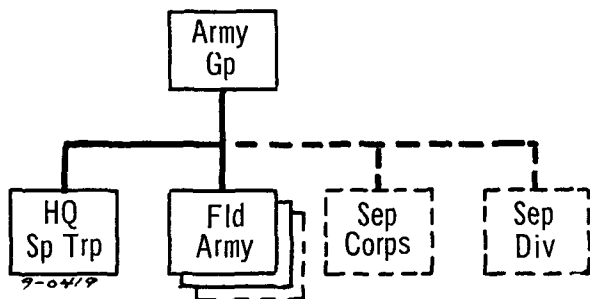
**LEGEND**

----- As required.

Figure 6-1. Typical army group.

6-5. Staff

a. Army group headquarters uses the U.S. Army general staff organization. FM 101-5 provides guidance on staff organization, procedures, and responsibilities of the general (coordinating) staff. The army group general staff provides policy, control, coordination, and direction for personnel and administration, intelligence, operations, logistics, and civil affairs.

b. Figure 6-2 provides a typical organization of an army group headquarters.

6-6. Strategic and Tactical Functions

The strategic and tactical functions of the army group headquarters are—

a. To translate broad strategic plans and instructions into operational plans for tactical execution by the subordinate units, usually field armies.

b. To direct all ground force operations within the boundaries of the army group.

c. To provide guidance for the conduct of future operations to its major subordinate commands.

d. To assign responsibilities for the execution of tasks to major subordinate commands.

6-7. Combat Service Support Functions

a. The army group is primarily a tactical unit and, as such, normally does not operate combat service support installations. Its headquarters is not in the automated system for

combat service support. The method employed by army group headquarters to discharge combat service support functions normally is one of these two methods:

(1) Army group headquarters directs field army (armies) to conform to group-established allocations and priorities when transmitting requirements to theater army support command (TASCOM).

(2) Army group headquarters recommends allocations and priorities to the theater army headquarters, which, in turn, directs TASCOM headquarters to restrict acceptance of field army requirements as necessary.

b. Army group—

(1) Establishes priorities for supplies and credits for its assigned and attached units.

(2) Establishes priorities for movements and insures adequate movements control and traffic control.

(3) Establishes priorities for the allocation of replacements to major subordinate commands.

(4) Allots available combat service support troops to major subordinate commands.

(5) Normally controls the allocation of ammunition to major subordinate commands. It may also control the allocation of other items and services in accordance with assigned tactical missions.

(6) Insures that subordinate units are adequately supported.

(7) Recommends the location of field army rear boundaries.

(8) Estimates the overall combat service support requirements to support army group operations and recommends the allocation of appropriate means.

(9) Assigns territorial responsibility to its field armies.

6-8. Planning and Conducting Operations

a. The army group prepares plans for its operations. Plans include—

(1) The assignment of zones of action or sectors of responsibility to the field armies and other major subordinate elements.

(2) The army group commander's concept of operation.

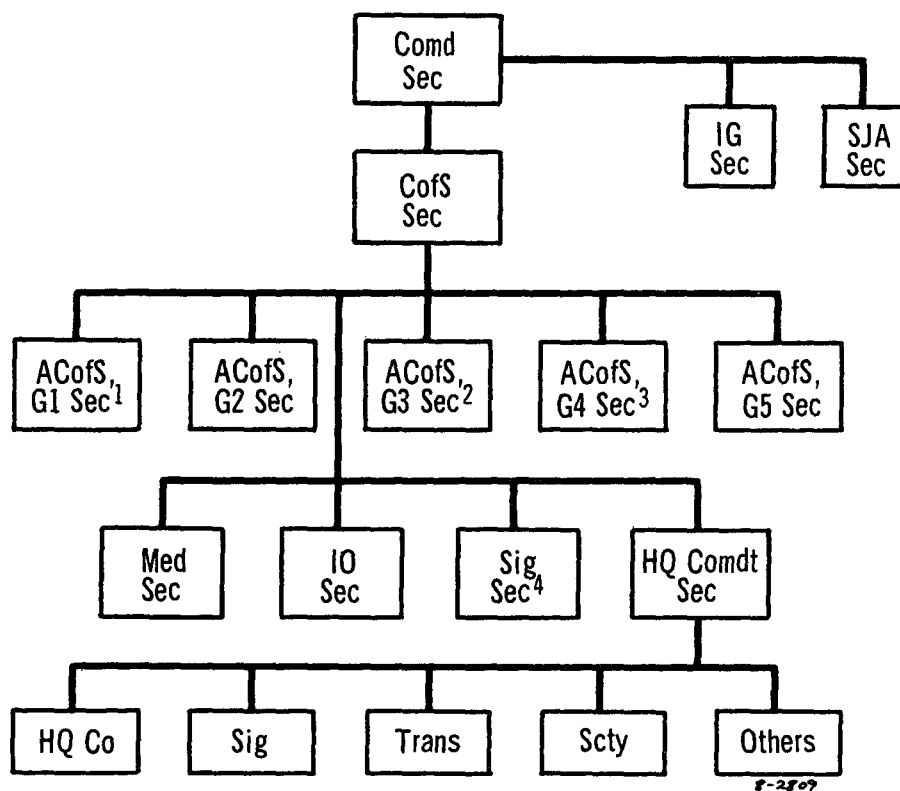

¹Includes AG, provost marshal, chaplain.

²Includes CBR, SW, PSYOP, avn.

³Includes engineer, ordnance.

⁴May be included in G3.

Figure 6-2. Army group headquarters.

(3) The allocation of means to the field armies.

(4) The assignment of broad missions and objectives to field armies and other major subordinate elements.

(5) The necessary measures for the coordination of the movements and efforts of the major elements of the army group. The army group commander normally publishes orders to the field armies in letters of instructions. The field army commanders are responsible for development of the more detailed tactical plans for the execution of the army group plans.

(6) Those measures required to conduct civil affairs operations.

b. Army group carries on both long-range strategic planning and short-range planning simultaneously. During current operations, the army group plans future operations, weeks and months ahead. In its operations, the army group uses all the personnel and materiel resources under its control. Sometimes rear area protection problems may require the army group to dispatch troops to the communications zone (COMMZ).

6-9. Tactical Air Support of Ground Operations

a. U.S. Air Force, Navy, and Marine air units provide tactical air support to ground

forces. Tactical air support is air operations carried out in coordination with surface forces, which directly assist the land or naval battle. Air operations can reduce the enemy's ability to continue sustained resistance. Tactical air support obtains information about enemy forces and terrain, provides close air support to the ground forces, restricts movement of enemy forces into and in the battle area, and provides airlift of troops, cargo, and supplies. Tactical air control systems are the command and control systems that tactical air forces develop and employ to control counterair (anti-air warfare), interdiction, close air support, air reconnaissance, airlift, special air warfare, and supporting air operations.

b. Close air support is air action against hostile targets in proximity to friendly forces which requires detailed integration of each air mission with the fire and movement of these forces. Elements of the tactical air control system ~~closely direct and control these actions.~~ Normally, the ground force element does not request close air support on targets that available ground weapons can destroy unless the additional air-delivered firepower will produce decisive results. Close air support may include support to unconventional warfare operations.

c. Air interdiction air operations are conducted to destroy, to neutralize, or to delay the enemy's military potential before it can be brought to bear effectively against friendly forces, at such distance from friendly forces that detailed integration of each air mission with the fire and movement of friendly forces is not required. Normally, air interdiction forces attack ground targets in proximity to friendly forces only at the specific request of ground forces or when it is desired to integrate the air interdiction program with the ground force fire plan and to insure troop safety.

d. Air reconnaissance is the acquisition of intelligence, employing visual observation and sensors in air vehicles. It provides the ground commander a means of obtaining timely information of terrain; weather, and the disposition, composition, movement, installations, lines of communications, and electronic and communication emissions of enemy forces. The

requirement for such information exists prior to the initiation of an operation and continues throughout the campaign.

e. Airlift provides air movement of troops, cargo, and supplies. The Air Force furnishes air line of communications (ALOC) to divisions and brigades as directed. It can deliver to lower echelons.

6-10. Coordination of Air-Ground Operations

a. The army group and the supporting air forces (to include Navy and Marine air resources) have complementary missions in the same general areas of responsibility. The army group conducts ground operations within its assigned boundaries. Supporting air forces conduct air operations in the same general area; however, air forces' area of operation extends deeper into enemy territory than the army group's to fully exploit the long-range capabilities of air weapon systems. Each commander has facilities for control and coordination of his tactical operations; each commander considers the needs and requirements of other commanders in formulating plans and conducting operations.

b. Commanders coordinate planning to insure maximum effective use of air resources available for support of the army group. Commanders coordinate air-ground planning at this level through the normal interchange of information between the two staffs and through command liaison between the two headquarters. Army group insures the establishment of fire support coordination lines (FSCL) by the appropriate ground force commander (normally corps). The FSCL is used to coordinate the supporting fire of forces not under the control of the appropriate ground force commander that may affect the current tactical operations. The FSCL is normally coordinated with the appropriate tactical air commander and any other forces furnishing fire support to the operations.

c. The primary elements of the TACS are—

(1) The tactical air control center (TACC), which is an Air Force agency collocated with the field army tactical operations center. It provides centralized control of the

total tactical air effort supporting each field army. It also provides the means of planning and committing forces to meet the Army's preplanned and immediate tactical air support requirements. The army group maintains liaison with this facility.

(2) The direct air support center (DASC), which is an Air Force agency collocated with the corps tactical operations center (CTOC). It can be assigned to an independent division.

(3) The Air Force, which provides tactical air control parties (TACP) from battalion through field army.

d. Daily, the theater commander normally decides the air effort to expend on tactical air support tasks. The air and ground component commanders submit recommendations in this matter. The theater commander notifies the Army and Air Force component commanders of the apportionment of air support resources. This information is relayed to supporting air forces, army group, tactical air force, and field army commanders. The field army commander allocates the apportioned air support to meet his requirements and those of major subordinate commanders. This allocation is forwarded to the supporting tactical air forces as a requirement. The TACC for the tactical air force prepares the daily air operations combat plan and directs the employment of weapons to meet the field army commander's requirement.

e. Chapter 7 provides a discussion of air-ground operations at field army.

f. FM 57-1 and FM 61-100 provide discussions of fundamental doctrine relative to Army participation in joint airborne operations.

6-11. Navy and Marine Corps Participation

a. The Navy and Marine Corps have primary interest and responsibility in amphibious operations and ground operations incident to the prosecution of a naval campaign, including air

operations relative thereto. FM 31-10, FM 31-11, FM 31-12, and FM 61-100 provide discussions of Army participation in amphibious operations. FM 31-12 provides a discussion of the fundamental doctrine relative to Army shore-to-shore operations.

b. The Navy and Marine Corps may, as a collateral mission, participate in air operations incident to a ground campaign. Normally, the Air Force provides the preponderance of the air effort; Navy and Marine Corps forces may assist in this effort. The Air Force commander normally directs the total air effort when the Air Force furnishes the preponderance of air support.

c. If the Navy or Marine Corps forces provide the preponderance of the air effort in support of ground operations, the Navy or Marine air commander normally directs the total air effort and conducts air-ground operations in accordance with their own system for tactical air direction and control.

6-12. Army Group Reserve

a. The retention of a maneuver element in army group reserve depends on the army group commander's tactical plan missions assigned to the field armies, the characteristics of the area of operations, the availability of friendly forces, and the enemy capabilities and probable courses of action. Normally, because of the lack of forces to form reserves at army group, the army group does not retain a maneuver element in reserve. Newly arrived units in the theater or units being rehabilitated and retrained may be the army group reserve.

b. Army group normally retains a reserve of nuclear weapons from the allocation that it receives from the theater army. Army group normally integrates such employment with the interdiction mission of the tactical air force.

c. Army group normally retains in reserve a portion of the tactical air support that it has been allocated.

CHAPTER 7

FIELD ARMY

(STANAG 2079, 2082, 2099, and 2104; SEASTAG 2079, 2082, and 2099; SOLOG 48, 49, and 130.)

Section I. GENERAL

7-1. Introduction

a. This chapter pertains to a U.S. field army composed of U.S. Army units operating—

- (1) Under a U.S. army group.
- (2) Directly under the unified command.
- (3) Directly under a subordinate unified command.

(4) Directly under U.S. theater army in those instances where the theater army commander has retained operational control of field army and has responsibility for direction of U.S. combat force operations.

b. The principles discussed herein also apply to a field army containing allied units or operating under the direction of a combined force headquarters.

7-2. Organization

a. The field army is a tactical and administrative organization composed of a headquarters, certain assigned army troops, a variable number of corps, and a variable number of divisions normally part of the corps.

b. The composition of a field army is not fixed; however, TOE 51-1 prescribes the organization of the field army headquarters and headquarters company. Higher headquarters assigns or attaches units to the field army. The field army may either further assign or attach units to the corps.

c. Higher headquarters bases the type and the number of troop units that it assigns or attaches to the field army on the mission, the characteristics of the area of operations, the availability of units, and the contemplated operation. For example, the troop list of a field

army deployed in jungle areas, savanna, and cultivated or industrial areas in a temperate zone and arctic areas would be organized for optimum operations in the respective areas.

d. The overall combat power of a field army is not restricted to that provided by the attached or assigned Army units. Supporting forces of the Army and other Services normally strengthen this combat power.

e. Figure 7-1 is an example of a field army.

7-3. Field Army Headquarters and Staff

a. TOE 51-1 prescribes the organization for the headquarters of a field army. This headquarters is augmented as required by the situation. Figure 7-2 is an example of a typical staff organization.

b. In combat operations, the field army headquarters consists of two echelons: the main and the rear. The main echelon consists of a main command post and an alternate command post. If necessary, the commander may establish a tactical command post. The rear echelon will be primarily concerned with combat service support. FM 101-5 provides a discussion of the echelonment of headquarters.

c. Field army headquarters uses the U.S. Army general staff organization. FM 101-5 provides guidance on staff organization, procedures, and responsibilities.

7-4. Field Army Tactical Operations Center

To assist in coordinating current operations, the field army commander may establish a field army tactical operations center (FATOC). FM 101-5 provides a discussion of the FATOC.

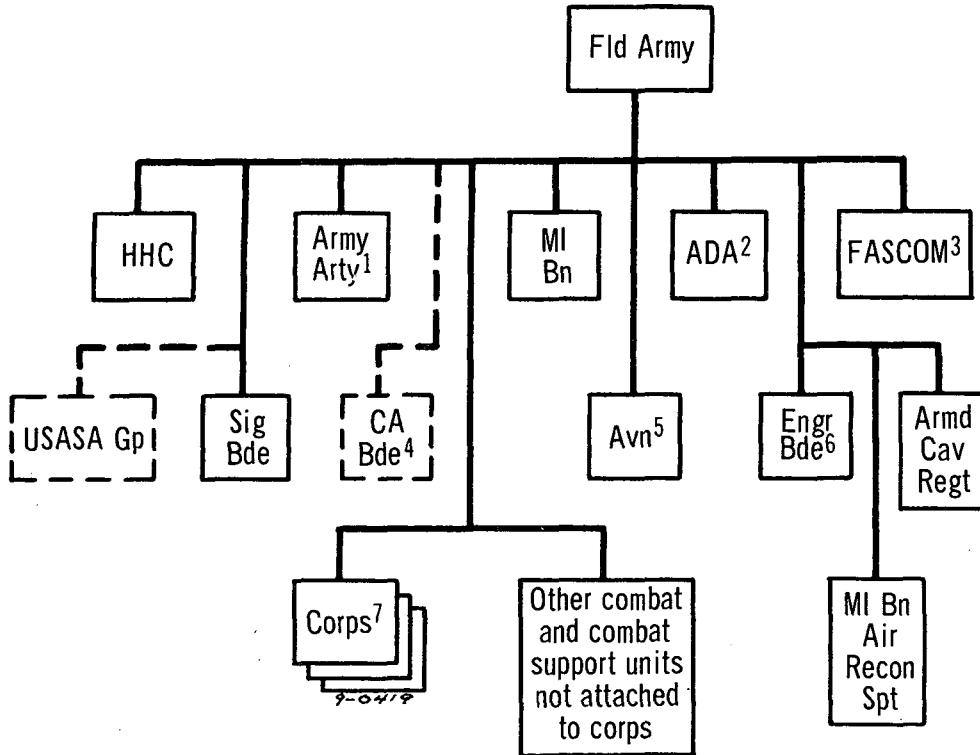

LEGEND

----- Attached as required.

¹Army arty section plus FA gp HQ and bns not attached to corps.

²HHC, ADA bde, plus ADA gp HQ and bns not attached to corps.

³For organization of FASCOM, see figure 7-10.

⁴Assigned one per fld army and may be attached to FASCOM.

⁵Avn co assigned. Other elements attached as required.

⁶HHC, engr bde, plus engr combat gps, and engr topo bn, Army.

⁷For organization of a typical corps, see figure 8-1.

Figure 7-1. Typical field army.

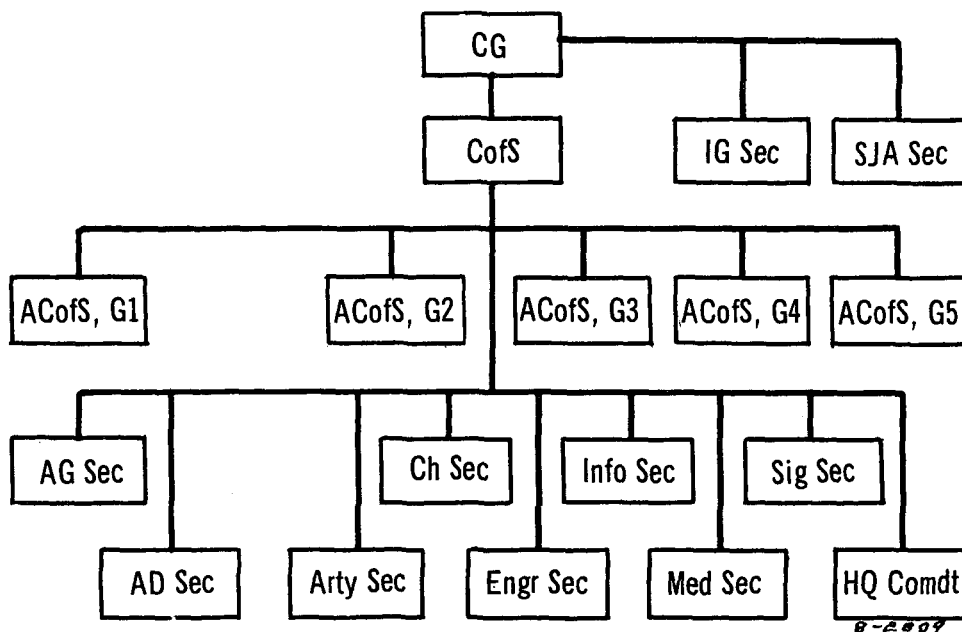

Figure 7-2. HQ, field army.

Section II. PLANNING

7-5. General

a. Field army planning supports the plans of the next higher headquarters—the army group, a joint task force headquarters, the unified command, U.S. theater army, or a combined force headquarters. The field army commander is normally aware of the next higher commander's contemplated operations and advises his major subordinate commanders of contemplated field army operations so that they can initiate their plans.

b. Field army projects its planning well beyond current operations. While one operation (or phase of the higher echelon campaign) that may extend over many days or weeks is progressing, the field army staff plans the next two or three operations or phases.

c. Planning at field army requires continuous and reliable intelligence as to the strengths, dispositions, composition, and probable courses of action of hostile forces. The field army commander employs all the information-gathering agencies available to him to secure information concerning the enemy forces opposing his command. These agencies also secure information

of those located in other areas but capable of affecting the execution of the planned field army operation, as well as information of terrain, weather, local civilian attitudes, and resources available within his area of operations.

7-6. Missions

Army group or other appropriate higher headquarters normally assigns the field army its mission in a letter of instructions. The field army mission is usually broad and permits the field army commander great latitude in its accomplishment. He must make a thorough mission analysis to determine the implied tasks that the letter of instructions did not specifically delineate but that he must accomplish if he is to fulfill his overall mission.

7-7. Command and Staff Actions

a. The sequence of command and staff action in planning field army operations is identical with that at lower echelons and follows the procedures outlined in FM 101-5. Reference in this manual to the commander's concept of operation is specifically directed to paragraph 3a

of the operation order, which states the commander's intent and visualization concerning the progression or flow of the operation.

b. Following his mission analysis, the field army commander issues his planning guidance to his staff as a basis for his staff estimates. In developing his initial staff planning guidance, the commander considers the requirements of all members of the general staff. In addition, he may provide guidance to the special staff members, e.g., the artillery commander and the air defense artillery commander. FM 101-5 covers planning guidance in greater detail; FM 101-31-1 further amplifies the nuclear aspects; and FM 101-40 provides guidance for employment of toxic chemical and biological (CB) weapons and defense.

c. Staff estimates help the commander to choose the best course of action to accomplish his mission. The field army commander considers the staff estimates, makes his own estimate, and arrives at his decision, which he amplifies as necessary for clarity and understanding. The commander's decision is the basis for preparation of the concept of operation (para 3a of the operation order). The concept of operation is the basis for the preparation of the field army operation order. The concept of operation treats such matters as the purpose of the operation, the development or phasing of the operation, the scheme of maneuver, the main attack or most critical sector, fires (including nuclear, biological, chemical, naval, and air), and other measures of significance to the entire force. The staff prepares the detailed plans, and the field army commander approves them for publication.

7-8. Phasing a Field Army Operation

a. A phase is a distinct period or subdivision of an operation at the conclusion of which the nature and characteristics of the action change

and the commander initiates another action. Phasing facilitates detailed planning for the execution of the commander's adopted course of action. By reducing the operation to phases, the commander can develop the details of execution as the operation progresses.

b. Because of their wide scope and long duration, the commander normally phases larger unit operations. A field army normally phases its operation when there is—

(1) A change in the form of maneuver or nature of the operation.

(2) A major regrouping of forces.

c. Considerations affecting phasing include the enemy capabilities and probable courses of action, friendly force dispositions, characteristics of the area of operations, combat service support, and distance.

7-9. Scope of the Field Army Operation Order

a. The field army operation order establishes the concept of operation for execution of the overall course of action adopted. It prescribes the details of execution for at least the first phase of the operation and outlines instructions for succeeding phases. At the appropriate time, additional orders are developed and published to cover succeeding phases. The commander normally issues the detailed operation plan for the next phase after the current phase is underway. He may use fragmentary orders if only minor changes to the current operation order are required.

b. The concept of operation and the assignment of tasks contained in the operation order permit major subordinate units to execute at least the first phase of the operation and initiate planning for one or more succeeding phases. The commander assigns tasks for succeeding phases on a "be-prepared" basis.

Section III. OPERATIONAL CONSIDERATIONS

7-10. General

The field army allocates each corps combat power commensurate with accomplishing its assigned mission. This allocation usually includes—

a. Maneuver units to include divisions, armored cavalry regiments, and separate brigades.

b. Conventional fire support to include field artillery and air defense artillery.

- c. Nuclear weapons.
- d. CB weapons.
- e. Tactical air support including Air Force, Navy, and Marine Corps.
- f. Naval gunfire support.
- g. Electronic warfare.
- h. Other support to include Army aviation, engineer, signal, psychological operations, civil affairs, and intelligence.

7-11. Maneuver Units

a. *Divisions.* The army group commander or other immediate higher headquarters may assign infantry, mechanized, airborne, airmobile, and armored divisions to the field army in any combination. The field army commander further places divisions under operational control or attachment to the corps in any combination that he desires to organize corps for the scheduled operation. Field army may retain divisions in its reserve. FM 61-100 covers division operations.

b. *Armored Cavalry Regiment.* The field army commander may use the armored cavalry regiment as a field army rear area security force, attach it to the corps, or hold it in field army reserve. The assignment of one armored cavalry regiment to each corps and one to field army is normal. FM 17-95 covers armored cavalry regiment operations.

c. *Separate Brigades.* Separate airborne, infantry, mechanized, and armored brigades may be assigned to the field army. Maneuver battalions of any type (infantry, mechanized, airborne, airmobile, or armored) may be assigned or attached or placed under operational control of these separate brigades. The brigades may be used on field army missions or may be attached or assigned to the corps under field army control. They may be used as a rear area security force or as part of the field army reserve. FM 7-30 and FM 17-30 discuss operations of the separate brigades.

7-12. Fire Support

a. *General.* In nonnuclear operations, maneuver is the dominant element. The commander plans his scheme of maneuver and develops the fire plan to support it. Fire support is highly flexible and is one of the principal resources

available to the commander for influencing the outcome of battle. The effective employment of firepower can be the decisive factor in accomplishing the commander's plan of action. In operations initially employing nuclear, biological, or chemical (NBC) weapons, these weapons may dominate the battlefield. In this case, the commander may plan the employment of his NBC weapons and develop the scheme of maneuver to exploit their effects. When NBC weapons are employed, the established principles for the coordination of fire support remain unchanged.

b. *Field Army Fire Support Means.* Field army fire support means consist of artillery firing high-explosive munitions and nuclear munitions in a surface-to-surface or in a surface-to-air role and armed helicopters providing air-to-surface direct fire support. Fire support means available to the field army with the capability may deliver CB munitions. Tactical air support from the Air Force, Navy, or Marine Corps (para 7-16) and naval gunfire support (para 7-18) normally supplement Army means.

c. *Field Artillery.* Except for the field army long-range ballistic missile delivery systems, the field army normally attaches all its field artillery to the corps.

d. *Air Defense Artillery.*

(1) The area (regional) air defense commander normally delegates field army commanders the authority for control and operational employment of organic Army air defense means within the field army area to optimize the air defense support of ground force scheme of maneuver. Field army and U.S. Air Force electronic coordination and control means must be compatible and operationally connected for optimum combat effectiveness.

(2) Air defense artillery units in the field army carry out their assigned missions within the policies and procedures established by the theater commander. The field army staff accomplishes coordination of air defense activities with tactical operations of field army units and the integration of air defense artillery weapons used in a surface-to-surface role with other ground fire support means.

(3) FM 44-1 provides discussion of air defense operations.

7-13. Nuclear Weapon Employment

a. Because of the nature of nuclear weapon effects, their employment is a major element of the commander's planning guidance. He may employ other fires and direct maneuver forces to extend and exploit the predicted effects of nuclear weapons. In the decisionmaking process, the commander gives careful consideration to employment of nuclear weapons in the development of courses of action. Nuclear weapons, because of their destructiveness, permit the adoption of courses of action not feasible in nonnuclear operations; therefore, the commander usually gives the same detailed consideration to the allocation of nuclear weapons that he gives to the employment of his major subordinate units.

b. The field army receives an allocation of nuclear weapons for a specific period, for a specific mission, or for a phase of the army group's (or other appropriate higher headquarters') operation. The allocation is expressed as a specific number of complete rounds in terms of the delivery system and yield. The commander uses the allocation as a planning factor. Additional authority is necessary for the actual dispersal of allocated weapons to locations desired by the commander to support his war plans. He cannot expend these weapons without release by proper authority.

c. Concurrent planning by field army and corps for the tactical employment of nuclear weapons is necessary to insure preparation of integrated and detailed nuclear fire planning and warnings. The executing commander issues friendly nuclear strike warnings to U.S. and allied forces.

d. The allocation of nuclear weapons to the corps follows the same procedures as the assignment of a mission. Field army may allocate nuclear weapons to the corps for a single phase of the field army operation or succeeding phases.

e. The field army's primary concern in allocating to the corps is the provision of the proper number and mixture of yields and types of weapons commensurate with their missions. The field army reserve includes nuclear weapons to be used for additional allocations to the corps and for succeeding phases.

7-14. Field Army Functions in Nuclear Weapon Employment

a. Commanders at the various echelons concurrently prepare plans for the tactical employment of nuclear weapons. Concurrent planning by field army and army group and by field army and corps is necessary to insure preparation of integrated and detailed nuclear fire planning.

b. The field army commander allocates weapons to the corps for the first phase of a field army operation. Additional authority is necessary for the actual dispersal of allocated weapons to locations desired by the commander to support his war plans. He cannot expend these weapons without release by proper authority. He also provides the corps with allocations for succeeding phases. He subsequently allocates these weapons as required. The field army retains a reserve for the entire operation. The duration of the allocation period differs at each echelon of command.

c. Field army normally fires long-range ballistic missiles on deep targets, but it may fire on more shallow targets in response to a request from a subordinate command. Some air defense weapon systems possess a surface-to-surface capability that field army may use to deliver nuclear weapons. When field army uses missiles in this manner, it must consider the requirements of the air defense mission.

d. Field army prescribes specific restrictions on the subordinate units' employment of nuclear weapons. Such restrictions may limit the employment of atomic demolition munitions (ADM), surface bursts, and nuclear weapons against large populated areas or their use in a specific area because of the requirement for future operations in that particular area.

e. Field army prescribes security measures for the protection of nuclear delivery systems and nuclear rounds. Security measures include provisions for the transportation of nuclear weapons from the special ammunition supply points to the delivery unit. Military police physical security companies assigned to FASCOM or attached to ammunition battalions normally provide intransit and static close-in physical security for special ammunition. The

field army standing operating procedures (SOP) usually includes these measures.

f. Responsibility for issuing necessary initial warnings to friendly forces rests with the executing commander. Commanders authorized to release nuclear strikes insure the coordination of strikes endangering the safety of adjacent or other commands with those commands in sufficient time to permit dissemination of warnings to friendly forces and the taking of protective measures. Conflicts must be submitted to the next higher commander for decision. FM 101-31-1 provides information on the employment of nuclear weapons and on the warning of friendly nuclear strike.

7-15. CB Weapons

a. Once the theater commander has authority to employ toxic CB weapons, field army fire plans should include the use of such weapons to support the scheme of maneuver. Toxic chemical weapons, biological weapons, and nuclear weapons are complementary. They provide the commander a wide range of effects and the capability of attacking a variety of targets varying from small, well-defined point targets to ill-defined and large area targets.

b. Since CB weapons, with the exception of incendiaries, do not destroy materiel, they do not have the associated total destruction resulting from the use of high-explosive munitions or nuclear weapons. CB agents provide a means of neutralizing personnel in areas where the destruction of physical facilities is undesirable, such as cultural centers, communications centers, or a major port that may be required for combat service support at a later date.

c. Toxic chemical agents are classified according to persistency (duration of effectiveness) as persistent or nonpersistent. Persistent agents normally are employed in terrain denial operations and remain in the target area for long periods, thus providing a casualty threat to individuals entering the area. Nonpersistent agents are quick acting and are employed either immediately before or during offensive operations for either lethal or incapacitating effects. Nonpersistent agents dissipate rapidly; therefore, they do not provide a casualty threat to individuals entering the area after an attack.

d. Biological agents are slower than toxic chemical agents in producing the desired effects. They are living organisms and are sensitive to weather conditions. After being re-

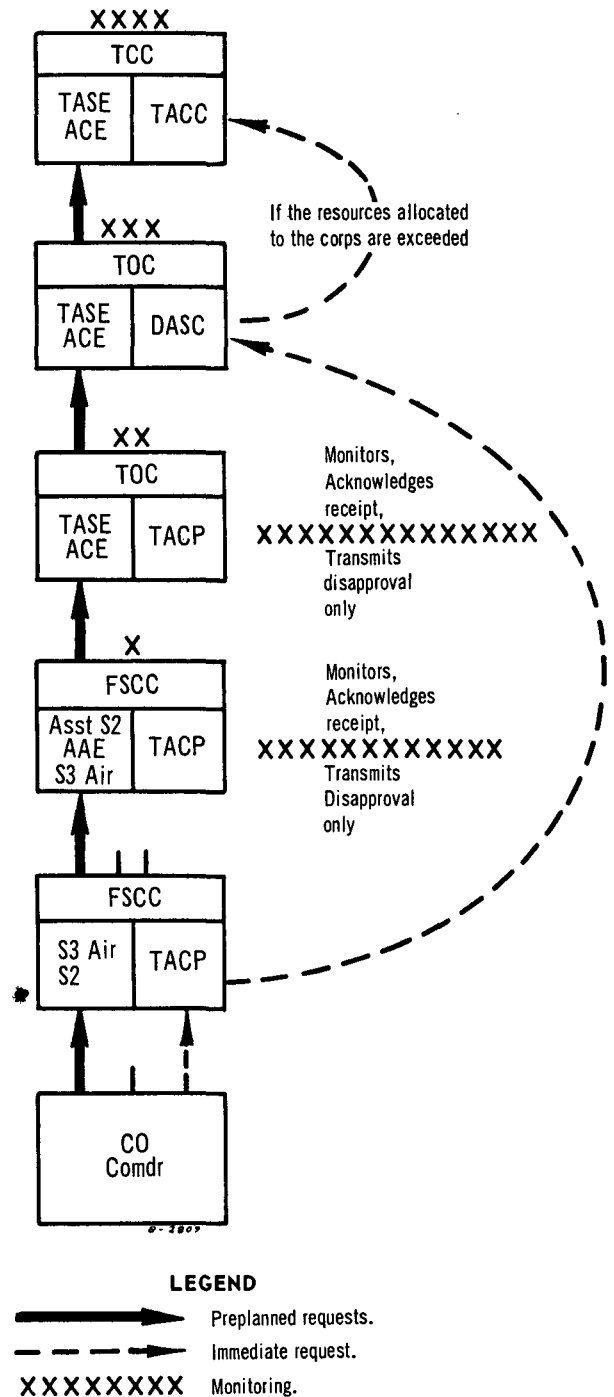

Figure 7-3. Channels for requesting close air support and air reconnaissance.

leased, they decay or die at a predictable rate. After invading an individual, biological agents grow and reproduce before symptoms of the disease can be detected. The incubation period (timelag between invasion of an individual and development of symptoms of the disease) is a consideration when biological operations are planned. Biological agents offer a wide range of incubation periods and effects. The effects may be lethal or incapacitating over varying periods of time.

e. To insure the most effective employment of CB agents, commanders and their staffs need to know what agents are available; their characteristics, capabilities, and limitations; the major factors affecting their employment; and the logistic factors involved in CB operations. FM 3-1, FM 3-10, FM 3-10A, FM 3-10B, FM 3-12, and FM 101-40 provide detailed discussions of CB operations.

7-16. Tactical Air Support

a. Field army ground operations and supporting air operations against hostile forces are complementary. Tactical air force planning for close air support, air reconnaissance, and airlift operations is integrated with the field army planning for ground force operations. The supporting tactical air force provides tactical air support in addition to the air support provided by organic Army aviation (para 6-9 and 6-10).

b. The tactical air support element (TASE) plans and coordinates close air support and air reconnaissance operations for the field army. The TASE is composed of G2 air personnel, G3 air personnel, and an air force tactical air control party (TACP). It may contain elements of the air/naval gunfire liaison company (ANGLICO). The G3 air plans and coordinates close air support operations; the G2 air plans and coordinates air reconnaissance operations.

c. The G3 and G4 jointly plan and coordinate airlift operations. The G4 plans and coordinates airlift of troops, cargo, and supplies for administrative moves and tactical resupply. The G3 plans and coordinates the airlift of troops in a tactical movement.

d. The appropriate ground commander, normally the corps commander, establishes a fire

support coordination line (FSCL) to insure coordination of fires by forces not under his control that may affect his command's current tactical operations.

e. The army group commander or other appropriate higher headquarters notifies field army headquarters and the supporting tactical air force agency as to the air effort available to support the field army.

f. Tactical air support missions are either preplanned or immediate. Preplanned missions are those for which a ground force commander can foresee a requirement in sufficient time to permit detailed planning and coordination. Operational plans, target information, and air effort available are bases for preplanned missions. Immediate missions are those for which the ground force commander cannot foresee a need in sufficient time to permit detailed planning and coordination. These result from the ground force commander's request for immediate support or from the appearance of an unexpected threat.

g. Commanders at all echelons in the field army process and forward preplanned tactical air support requests over the army air request net to the next command echelon (fig. 7-3, 7-4, and 7-5). Each echelon of command through field army approves requests that meet operational criteria and passes them to the next echelon. The TASE at field army takes final action on the requests and forwards them to the tactical air control center (TACC) or requirements.

h. Commanders at any army echelon can request immediate air support. Companies forward support requests to the battalion command post (CP) by the most rapid means (fig. 7-3, 7-6, and 7-7). If battalion approves, the battalion TACP forwards the request over the Air Force-operated air request net to the direct air support center (DASC) located at corps or independent division level. The TACP at each higher echelon monitors these transmissions, acknowledges receipt, and passes the request to the TASE at its level. Normally acknowledgment of the request by intermediate TACP indicates approval by the associated headquarters unless a disapproval is transmitted within a specified time or the ground commander de-

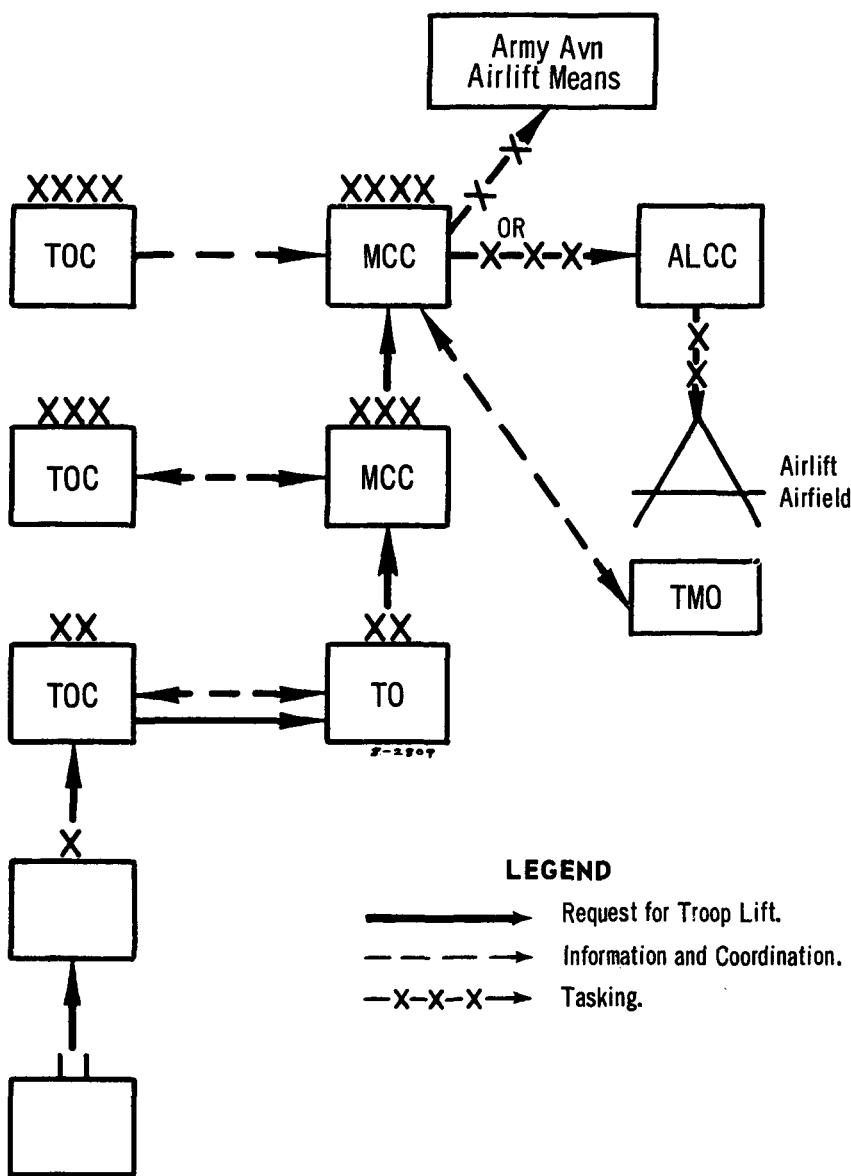

NOTE: Requests are satisfied at the lowest echelon capable of fulfilling the requester's needs.

Figure 7-4. Preplanned request channels for airlift of troops.

sires that approval be stated by specific transmission. Coordination takes place at all echelons simultaneously. If the ground commander, at any echelon, disapproves the request, the monitoring TACP notifies the DASC and the requester and the request is canceled. If the headquarters where the DASC is located or a higher headquarters disapproves the request, the DASC notifies the originator and the re-

quest is canceled. FM 61-100 contains detailed request procedures for tactical air support.

i. When requests exceed the air effort available, the field army can request the army group commander or other appropriate higher headquarters to reapportion the available air effort. The field army commander also may make aircraft available for a high priority mission by diverting it from a mission of lesser priority.

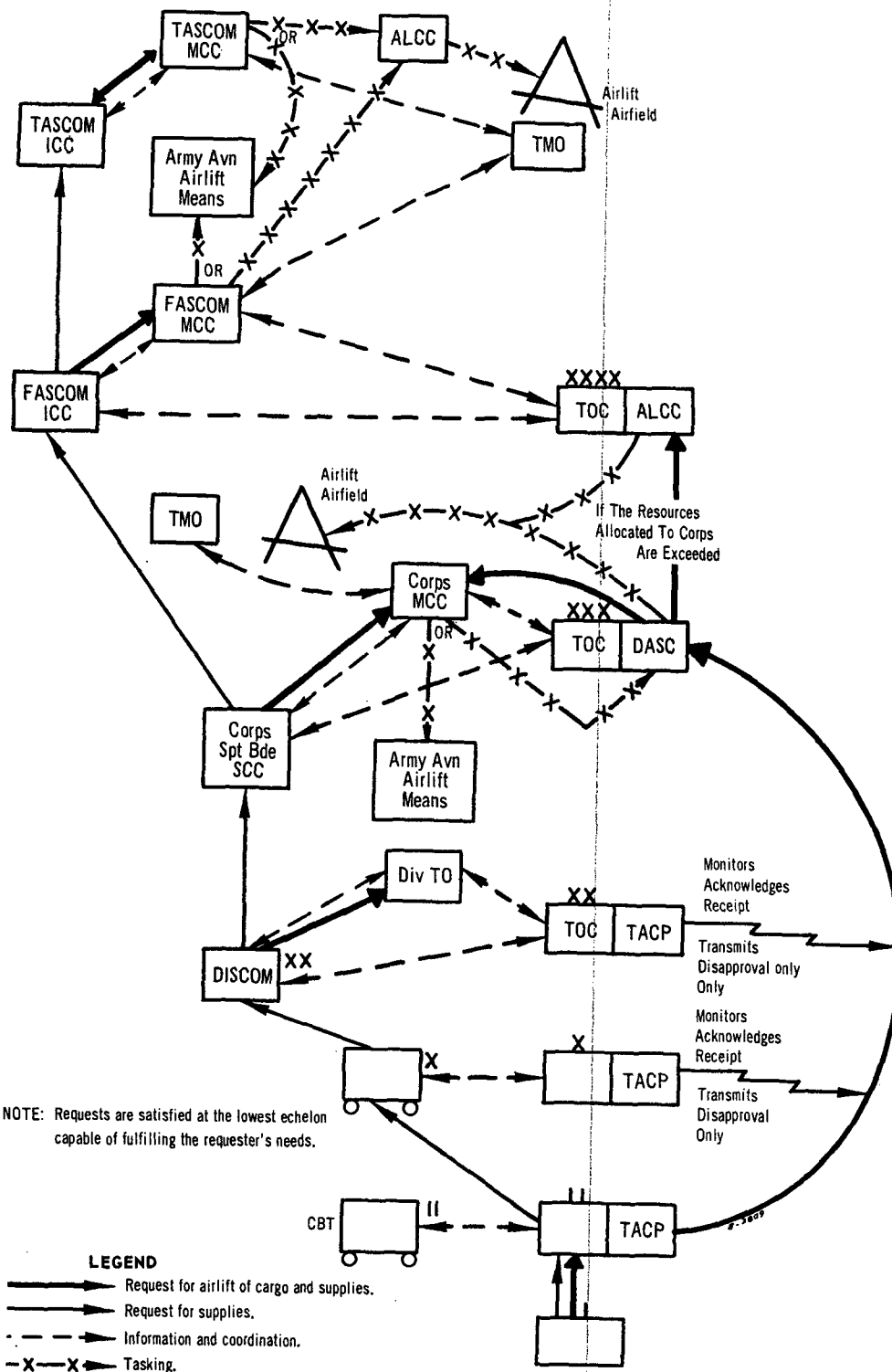

Figure 7-7. Immediate request channels for airlift of cargo and supplies.

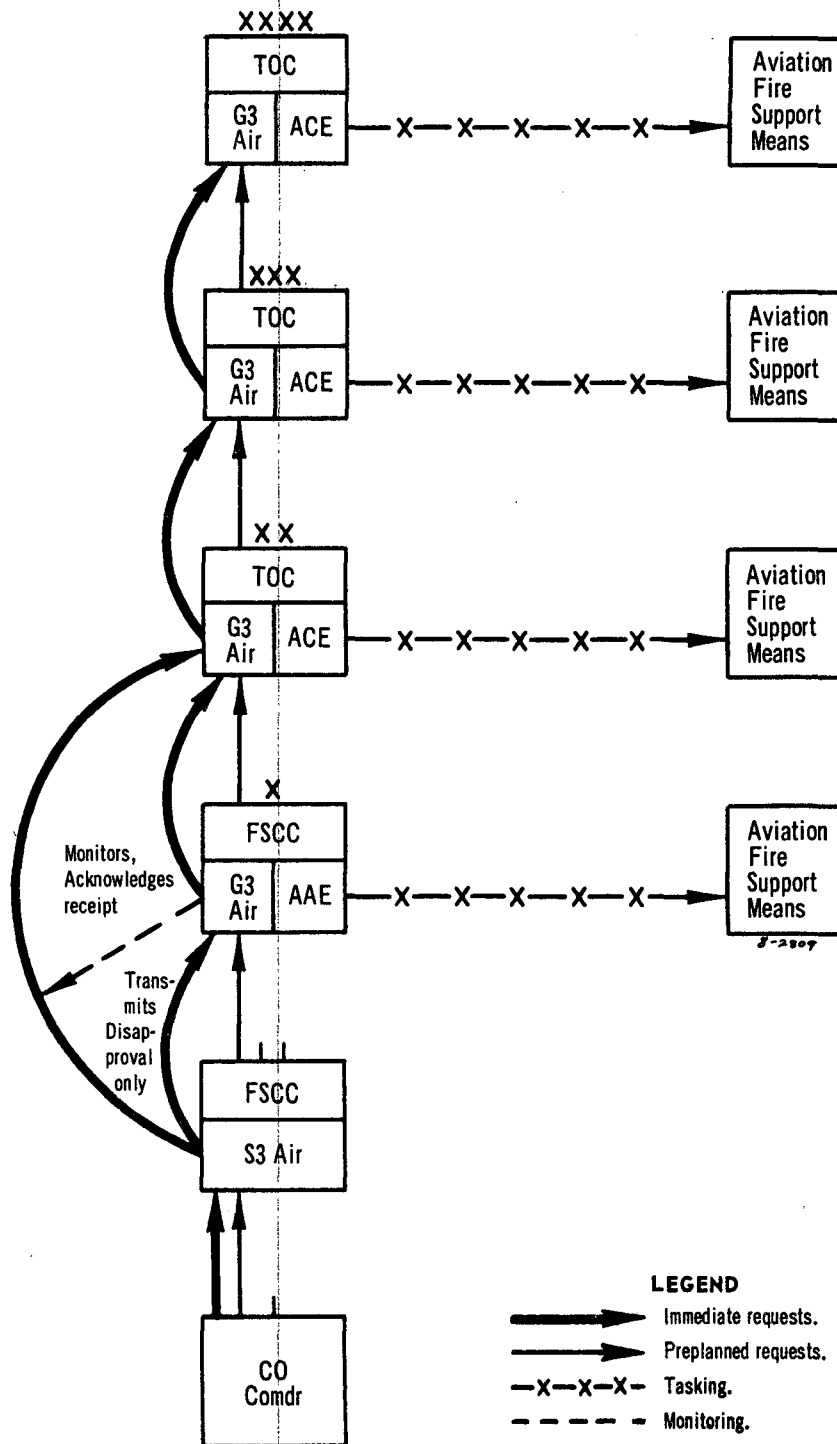

Figure 7-8. Armed helicopter fire request channels.

and aerial artillery units provide the primary source of armed helicopter fire support. These

units are normally attached to or placed in support of lower echelons. Any echelon can ini-

tiated preplanned or immediate fire requests for this support.

b. Ground forces submit fire support requests to the fire coordination center at battalion and brigade or to the tactical operations center (TOC) of division and larger units. The G3 air aided by the airspace control element (ACE) processes armed helicopter fire support requests. Aerial artillery support is requested through artillery fire support channels. Requests are planned and accomplished at the lowest echelon having available means to provide the requested fire support (fig. 7-8). FM 61-100 contains a detailed discussion of procedures for requesting armed helicopter fire support.

7-18. Naval Gunfire and Naval Close Air Support

a. Naval gunfire (NGF) and naval close air support support ground forces during amphibious operations. Naval forces may continue to provide this support to ground forces after termination of the amphibious operation. FM 6-20-1 and FM 31-12 provide detailed discussions of fire support in amphibious operations.

b. Naval forces may also provide NGF and close air support to ground forces when the supporting ships are within range of the target area. The ground force commander is responsible for determining his requirements for this support. Naval gunfire and close air support are integrated with other fire support means at the appropriate fire support coordination facility.

c. When naval fire support is available, naval liaison officers at all echelons from battalion through army group advise and assist the commander in the employment of naval gunfire and close air support. The Navy designates ships to provide direct support to specific units such as battalions. These ships also furnish general support to brigades, divisions, or higher echelons. Normally a Fleet Marine Force air/naval gunfire liaison company ANGLICO is attached to each supported Army division. The attached ANGLICO elements include Navy and Marine personnel who advise on the employment of naval gunfire and naval close air support and provide the communica-

tions necessary to request, direct, and control this support.

d. The naval gunfire liaison officer (NGLO) naval gunfire liaison party (NGLP), or naval gunfire liaison (NGL) team monitors and coordinates all calls for fire from air and ground naval gunfire spotters (fig. 7-9).

e. FM 61-100 provides discussion of the organization and employment of the ANGLICO.

7-19. Electronic Warfare

a. The extensive use of electronics for the command and control of forces, operation of equipment, and employment of weapons has introduced an electromagnetic environment that is a major component of the military environment. Electromagnetic radiations, whether intentional or unintentional, directly reflect the command and control arrangement and other elements of the organization with which they are associated. From these radiations, the commander can determine hostile command and control and other systems and selectively disrupt or deceive them to support the force mission.

b. An electronic warfare system that enables the commander to reduce the effectiveness of hostile electronic activities and, at the same time, insures effective use of his own electronics represents a powerful weapon in support of both offensive and defensive operations. Electronic operations conducted within the field army include intelligence, target acquisition, jamming, tactical cover and deception, security, and command and control. The first four categories constitute the commander's electronic combat power because the objective here is to gain knowledge of the enemy and to impose the commander's will on him. Security measures and command and control procedures are defensive in nature and include the electronic measures that lessen the vulnerability of the field army command and control system to enemy disruption and exploitation.

c. Electronic warfare is integral to military operations at each echelon. The field army commander is responsible for integrating electronic warfare operations into his operational planning. Electronic warfare units are provided to assist in accomplishing this responsibility.

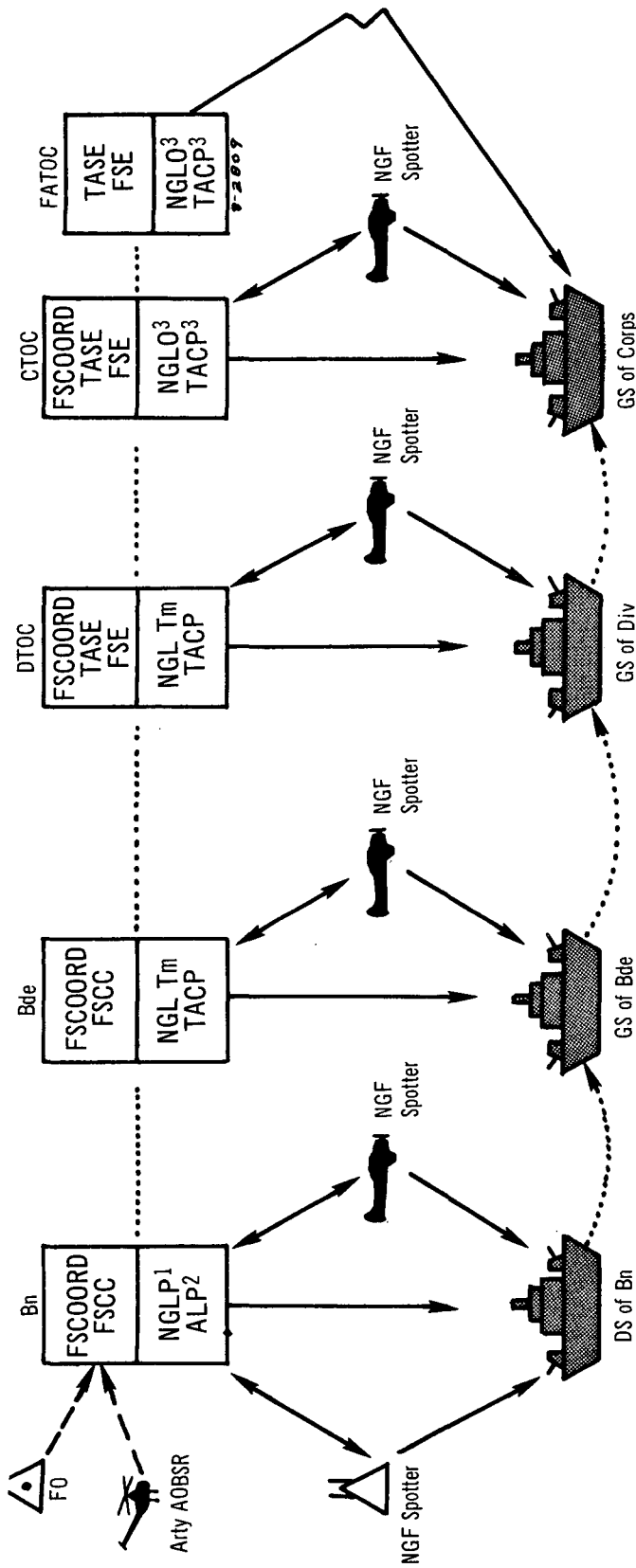

LEGEND

→ Call for fire from supported unit to supporting ship via ANGLICO channels.

- - - - - Call for fire from artillery forward observer.

..... Call for additional fire.

¹Naval gunfire liaison party (NGLP).

²Air liaison party (ALP).

³Provided as required.

NOTE: NGLP/NGL tm/NGLO monitors and coordinates all calls for fire from air and ground NGF spotter.

Figure 7-9. Naval gunfire and naval close air support channels.

d. AR 10-122, AR 105-87, FM 32-10, and FM 32-20 provide detailed discussions of electronic warfare.

7-20. Other Field Army Combat Support

a. *Army Aviation.* Army aviation elements provide the supported commander with helicopters and fixed-wing aircraft. The field army employs these aircraft to support the ground units in their performance of the functions of combat; e.g., mobility; firepower; combat service support; command, control, and communications; and intelligence. The field army habitually places a portion of its Army aviation units under operational control of or attachment to corps and retains a portion under field army control. Army commanders are provided the services of Army aviation units that can perform the following functions:

(1) *Command, control, and communications.* This includes airborne command post, courier and liaison missions, control of movements, message drop and pickup, and wire laying.

(2) *Observation and surveillance.* Army aviation provides air observation over the operational area. It observes, adjusts, and registers indirect artillery fires. Through this capability, it supports intelligence-gathering activities and target acquisition. Additionally, it conducts flights in support of air survey operations and air radiological surveys.

(3) *Mobility.* By airlifting troops and combat equipment, Army aviation provides an additional means of maneuver to the ground commander. Army aviation's airmobility capability permits rapid emplacement of weapons and quick transportation of troops over obstacles.

(4) *Firepower.* Army aviation provides armed helicopters to furnish responsive direct aerial fire support against personnel and materiel on area or point-type targets to include the launch and control of anti-mechanized air weapon systems. Armed helicopters and aerial artillery help to fill the gap between the support provided by conventional ground fire means and close air support provided by tactical aircraft of other Service components.

(5) *Combat service support.* Army avia-

tion supports combat service support operations by providing air movement of troops and materiel, air movement of patients, and evacuation of damaged equipment within the combat zone. FM 1-100, FM 1-20, and FM 57-35 cover Army aviation organization and employment.

b. *Engineer.* Engineer combat units perform combat engineering to impede enemy mobility and to assist the movement of U.S. forces. Each corps and field army normally has attached an engineer brigade headquarters. The engineer brigades are organized to accomplish the engineer tasks within their respective areas by attachment of an appropriate mixture of engineer combat groups, battalions, and separate companies. The engineer brigade assigns combat support and construction missions or tasks or both to the engineer combat groups and organizes them for specific missions by attaching the appropriate number of combat battalions and separate companies. FM 5-1, FM 5-142, and FM 5-162 cover engineer support of corps and field army operations in detail.

c. *Signal.* The field army communications system is installed and operated by signal battalions assigned to the field army signal brigade. The field army communications system consists of a command communications system superimposed on an area system. The army command communications system is provided from the field army headquarters to the corps and certain major subordinate units. The system provides multichannel communications and high-frequency radio communications. The army area communications system consists of area signal centers located throughout the field army in the areas of greatest troop density. These centers are interconnected by means of multichannel radio and cable trunking facilities. This system extends from the field army rear boundary into the divisional zones and provides common signal support to its subscribers. It connects with the theater army communications systems (TACS) and provides a multichannel system to the division support command. The field army communications system provides the following common signal support and facilities to its subscribers: telephone, teletypewriter, facsimile, data transceiver, radio, radio wire integration, and messenger

service. FM 11-75, FM 11-86, and FM 11-95 contain discussions of the field army communication system in detail.

d. Psychological Operations. Psychological operations (PSYOP) are conducted within policy guidance from theater army or other appropriate headquarters. They are designed to reduce the combat effectiveness of enemy armed forces and to influence hostile, neutral, and friendly groups to support the operations of the field army. Opportunities determined through the continuous evaluation of intelligence are quickly exploited. The field army commander is responsible for the integration of psychological operations into overall military planning. He allocates psychological operations resources from the psychological operations units or teams to subordinate commands. FM 33-1 and FM 33-5 cover details of psychological operations.

e. Chemical. The army group or other appropriate commander normally assigns chemical smoke generator units to field army and attaches them to corps or divisions when supporting these units. FM 3-50 discusses chemical smoke generator units and smoke operations in detail.

f. U.S. Army Security Agency. Normally a U.S. Army Security Agency (USASA) group with its subordinate units supports the field army in rendering that tactical support effort specified in AR 10-122. FM 32-10 provides a detailed discussion.

g. Long-Range Patrol Elements. Army group or other appropriate headquarters normally allocates long-range patrol (LRP) companies on the basis of one per field army and one per corps. The LRP company is a specially trained and equipped unit organized specifically to perform reconnaissance, surveillance, and target acquisition. FM 31-18 contains details of employment of LRP units.

h. Military Intelligence. Military intelligence (MI) units provide specialized intelligence support to the field army commander. A military intelligence group or battalion is assigned to each field army in a theater of operations. The military intelligence units are designed to support field army headquarters and tactical subordinate commands of the field army in the accomplishment of their intelligence mission. FM 30-9 covers intelligence support of field army and corps operations in detail.

Section IV. COMBAT SERVICE SUPPORT

7-21. General

a. Theater army or other appropriate headquarters allocate combat service support means to the army groups or field armies to support the plan of campaign. Field army further allocates these means or employs them, based on the recommendations of the corps, to support their corps and divisions in furtherance of the field army plan of operation.

b. Combat service support is an important consideration at any level of command in the planning of tactical operations. In planning the operations of larger units, other things being equal, the capability to support logistically one particular course of action may be the controlling factor in the commander's decision. Once the commander announces his decision and concept of operation, the staff can develop the field army plan, which includes the allocation of combat service support units and the establishment of priorities for combat service sup-

port adequate for the accomplishment of the tactical mission. Thus the combat service support and the combat and combat support means weight the main tactical effort.

7-22. Organization for Combat Service Support

a. The field army support command (FASCOM), a major subordinate command of the field army, is responsible to the field army commander for providing combat service support for the field army. This responsibility includes long-range planning for support of operations, detailed planning for and provision of support for immediate operations, and day-to-day coordination with units of the theater army support command (TASCOM) in the communications zone (COMMZ). Figure 7-10 shows a typical FASCOM organization.

b. The FASCOM headquarters normally is in the army service area. Control centers pro-

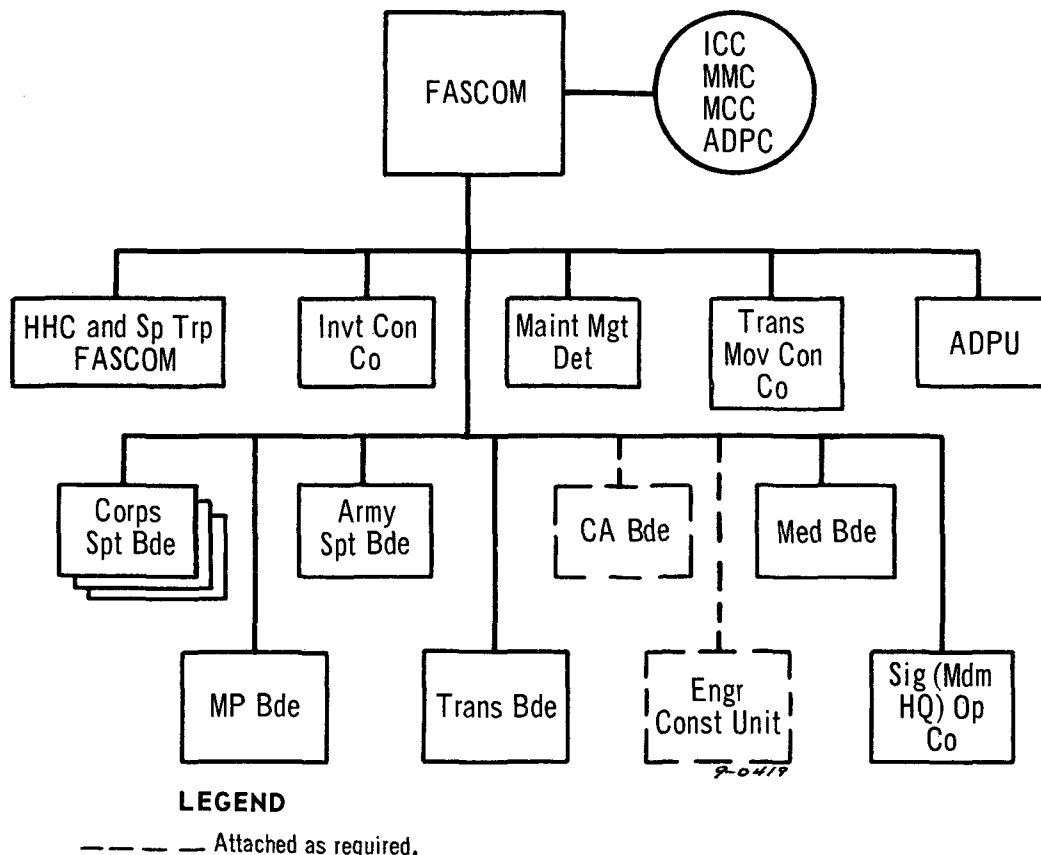

Figure 7-10. Typical field army support command.

vide centralized management for field army supplies, maintenance, and movements. Combat service support is provided by subordinate brigades. Combat service support units are assigned to field army and provide combat service support in accordance with policies and procedures established by theater army and the commands supported. Employing management by exception techniques, field army headquarters monitors FASCOM combat service support and takes necessary action to insure its effectiveness. FM 54-3 gives details of the FASCOM headquarters organization.

c. The FASCOM in figure 7-10 is designed to support a typical field army of three corps of four divisions each engaged in sustained ground combat. For larger forces or for longer operations, FASCOM operating units can be organized to meet the requirements imposed by the size and mission of a force, resource limitations, and environmental conditions.

d. Support brigades can provide supply and services, maintenance, movements, transportation, personnel and administration, and military police support. Each corps support brigade provides this support to a designated corps. However, in the field army service area, the army support brigade provides this same support less transportation, military police, and ammunition service. Each brigade normally has two composite support groups that furnish supplies less ammunition, together with maintenance of most kinds of equipment. These groups use throughput and scheduled delivery of unitized supplies where possible. Each corps support brigade has an ammunition group that provides ammunition supply and ammunition/missile maintenance to a corps slice of the field army. Engineer elements of field army, not the FASCOM support brigades, furnish potable water, maps, and construction services.

e. The medical, transportation, and military police brigades provide their respective services on an army-wide basis. A military police battalion and a motor transport battalion are assigned to each corps support brigade. FASCOM commanders can attach elements of the army-wide service brigades to the support brigades to provide support on a temporary basis, if required. However, centralized control is preferred because fragmentation of these units reduces their effectiveness.

f. The Civil Affairs Brigade, normally allocated on the basis of one per field army, provides civil affairs support to all field army units. Normally, civil affairs authority for the field army service area is delegated to the FASCOM Commander.

g. The FASCOM commander is also responsible for rear area protection (RAP) in the

army service area. He normally delegates this function to the army support brigade commander (para 7-23). FASCOM units, including the corps support brigade headquarters, deployed in corps rear areas are responsible for their own RAP efforts and for providing mutual assistance to adjacent units within their capability. They perform these responsibilities in conformance with the plans and directives of the corps commander.

h. The FASCOM military police brigade operates field army prisoner of war facilities to which prisoners of war are evacuated from division collecting points. After interrogation, the military police prisoner of war brigade of the TASCOM personnel command may evacuate them to COMMZ. FM 19-40 and FM 100-10 provide procedures for prisoner of war handling.

Section V. REAR AREA PROTECTION

7-23. RAP

a. The FASCOM commander plans and conducts RAP operations in the army service area. The commanding officer, FASCOM army support brigade, normally has this mission. A rear area operations center (RAOC) normally is assigned to each support group of the army support brigade. RAOC coordinates RAP activities and acts as a focal point for the receipt and dissemination of information. Most combat support and combat service support units have a RAP capability built into their table of organization and equipment (TOE). Their training, planning, and operations in RAP matters are coordinated by RAOC's. For these centers to operate properly, the FASCOM commander—

(1) Clearly defines areas for RAP purposes and insures that all units are aware of their respective RAP areas.

(2) Establishes unit priorities for RAP purposes.

(3) Designates areas and subareas as "critical," "priority," or controlled.

(4) Clearly delineates command and control arrangements for RAP purposes.

All commanders are responsible for RAP (local security and damage control) at their

respective units and installations. Local security for U.S. Air Force and Navy installations is a responsibility of those Services. Designated commanders are responsible for coordinating RAP efforts within their area of responsibility. FM 19-45 and FM 100-10 provide details and discussions of RAP and organization for RAP requirements.

b. The field army commander may physically locate tactical forces in the field army service areas and direct them to conduct rear area security operations in support of the FASCOM. These forces conduct limited screening and intelligence activities. Their primary mission is to act as a mobile strike force. Tactical force commanders designated to support the FASCOM commander normally operate under mission-type orders.

c. Units located in the rear area can provide surveillance of local areas and report intelligence and damage or contamination information. FM 3-12 provides guidance on radiological contamination reporting. FM 21-40 contains information pertaining to NBC reports. Allied forces are trained as required, and all capabilities of a friendly government are used. Military police units, because of their detached mobile deployment, have a limited capability of

conducting counter guerrilla activities alone or in concert with civilian police and paramilitary security forces.

7-24. Tactical Reinforcement

Airborne, guerrilla, or other attacks may occur that are beyond the FASCOM commander's defense capability. In this event, the field army

commander decides the priority of effort, decides whether additional tactical troop reinforcements are diverted to the area under attack, and may attack such forces to the FASCOM. The FASCOM commander may delegate authority for rear area security to a tactical commander when the tactical forces are attached.

Section VI. FIELD ARMY IN STABILITY OPERATIONS

7-25. Field Army Role in Stability Operations

a. A force as large as a field army normally is not deployed in support of stability operations; however, the field army commander may be required to train, equip, and dispatch elements for these operations. The staffs of larger units such as field army, corps, and division may have to advise host country counterparts.

b. Situations may arise in the course of other operations in a theater of operations that could cause the field army to be involved with stability activities.

7-26. Principles

a. Higher headquarters directs field army stability operations. Field army uses all stability operations capabilities in a coordinated effort. FM 100-20 and FM 31-23 contain guidance for the actions of a larger unit in actual or potential stability operations situations.

b. The U.S. military objective is to increase the overall capability of the host country military, paramilitary, and other security forces to maintain or restore a climate of order within which responsible government can function effectively. Military assistance can range from advisory assistance (FM 31-73) in training and employment of individuals and units, reinforcing a military assistance advisory group (MAAG) or mission, up through the employment of combat elements of U.S. military forces. Military capabilities that all branches of the U.S. Army can bring to bear on the internal defense problem generally parallel those of host country armed forces. These capabilities include advisory assistance and civil affairs, psychological, intelligence, populace and resources control, and tactical operations.

c. Discontent and unrest caused by economics, political, sociological, ethnic, or religious groups or other factors that could lead to covert or overt insurgent activities may be latent in any political community. Insurgent actions range in scope and degree of violence from subversive political activity to combat by large guerrilla elements. The early recognition and identification of these activities and the prompt initiation of internal defense and internal development programs are of vital interest to the military commander concerned.

7-27. Planning

a. The three phases in the escalation of insurgency outlined in Communist doctrine, without distinct demarcation between phases, can be classified as follows:

(1) Phase I, the potential subversive situation and the initiation of corrective or suppressive measures by established authority.

(2) Phase II, the outbreak of organized guerrilla warfare or related violence against established authority requiring military action by government forces.

(3) Phase III, the war of movement between organized forces of the insurgents and those of established authority.

b. The U.S. field army commander in a theater of operations whose mission is to assist the host country may have to redeploy his forces to meet the situation. When the army is directing corps combat operations or defensive cold war operations along a front or border, it maintains the main troop dispositions and conducts counter guerrilla tactical operations as a normal rear area security mission. When no frontal attack or border threat exists in the theater, the field army commander deploys his

forces as dictated by his mission, the situation, terrain, operational environment, and instructions of higher headquarters. When required, field army missions may include—

(1) Reinforcing MAAG or missions in countering phase I insurgency operations by providing specialists, mobile training teams (MTT), and other support.

(2) Providing advisers and instructors and combat support and combat service support units to the MAAG in internal defense assistance operations to defeat phase II insurgencies.

(3) Providing combat, combat support, and combat service support units to operate with host country forces when the insurgency escalates to phase II or phase III insurgency operations. FM 100-20 provides further discussion of the phases in the escalation of insurgency.

7-28. Initial Operations

The field army commander, as directed by higher headquarters—

a. Directs the efforts of his command to assist the host country in preparing comprehensive national internal defense plans designed to integrate and coordinate measures for preventing insurgent acts of violence and preserving law and order.

b. In coordination with MAAG, missions, Agency for International Development (AID), United States Information Service (USIS), and other agencies assist in the training, motivation, and outfitting of civil police, paramilitary, and civilian officials. These actions are most effective at the incipient stages and may

preclude the need for large-scale counterinsurgency warfare actions at a later period.

c. Emphasis training of U.S. military personnel in military civic action, psychological operations, language facility, country and area orientation, and active and passive counterinsurgency operations. The roles and missions of nonmilitary agencies are a part of the orientation of military personnel.

d. Implements, in concert with host country agencies and U.S. nonmilitary intelligence agencies, intelligence plans designed to detect and report dissident individuals and groups. He directs the collection effort to determine local conditions and situations conducive to unrest. The field army commander takes measures through host country and U.S. agencies in the country to locate and confiscate or control weapons, explosives, and tools of sabotage.

e. Assists, in coordination with USIS or other nonmilitary U.S. agencies in the country, the host country in conducting an aggressive public information program that disseminates factual reports to the population, thereby neutralizing and discrediting subversive propaganda.

f. Requires increased security measures within U.S. installations and organizational sectors.

g. Is prepared to conduct additional operations.

h. FM 31-16, FM 31-22, FM 31-23, FM 31-73, and FM 41-10 provide detailed information concerning employment of U.S. Army forces in counterinsurgency operations, stability operations, and special action force operations.

Section VII. OFFENSIVE OPERATIONS

7-29. General

a. Paragraphs 7-10 through 7-20 discussed the means available to the field army together with general principles or procedures for employment in all types of operations. This section covers aspects of planning and conducting field army offensive operations and should be considered in conjunction with the general operational considerations outlined in paragraphs 7-10 through 7-20.

b. In major offensive operations, the field

army secures and retains the initiative, thus permitting the commander to direct his movements and to employ his forces in a decisive manner of his own choosing. An offensive that gains tactical surprise and is prosecuted with vigor may accomplish the mission before the enemy can take effective counteraction. In general, a large-scale offensive requires great impetus; sufficient reserves of men, NBC weapons and materiel; and adaptable plans to insure success and continuity of effort. FM 100-5

provides a detailed discussion of offensive operations.

7-30. Missions to the Corps

a. The field army commander's decision and concept of operation are translated into missions or objectives for each of the corps and for other major subordinate commanders reporting directly to field army headquarters. Preferably he assigns the corps missions rather than specific terrain objectives because the latter tend to restrict the corps commander's freedom of action.

b. A field army offensive operation may take weeks to complete and may cover great distances. For the field army commander to assign missions to the corps for the entire operation is impracticable. He assigns missions to subordinates for one phase of the field army operation, with conceptual guidance indicating in general terms the nature of likely future operations. The assignment of missions and the field army commander's concept of operation permit the corps to plan one phase of the field army operation in detail and to initiate planning for succeeding phases (para 7-9).

7-31. Corps Zones of Action

a. After translating the field army commander's decision and concept of operation into corps missions, field army assigns zones of action by designating boundaries. Each echelon uses boundaries to delineate the zone (area) responsibility of commanders, to insure coordination between adjacent commanders, and to enhance the control of the next higher commander. Field army designates the location of the corps boundaries.

b. In locating corps boundaries, field army provides lines of communications and maneuver space for the corps. Each corps requires an adequate road net and sufficient maneuver room to execute its tactical plans.

7-32. Operations During Employment of Nuclear Weapons

a. Friendly employment of nuclear weapons in support of ground forces involves possible risk to friendly forces. Enemy use of these weapons provides a serious threat to all

friendly forces. The scale of use of nuclear weapons in an operational environment, whether restricted or unrestricted, is the major factor influencing the combat units' ability to maneuver effectively. FM 100-5 provides a discussion on scales of usage of nuclear weapons.

b. A nuclear saturated battlefield may drastically reduce the ground forces' ability to maneuver decisively. Larger units normally are unable to maneuver without prohibitive losses. Airmobile forces and other ground units up to battalion frequently are able to move with sufficient freedom to permit them to continue effective operations.

c. Following the nuclear weapon exchange, rapid reconstitution of the combat and combat support elements is necessary to resume or initiate offensive operations. Since both combatants undoubtedly suffer severe damage during a nuclear weapon exchange, small, highly mobile forces may achieve decisive offensive results when employed aggressively and in a timely manner. Field army insures that additional forces are reconstituted, equipped, and committed to action as resources and the operational environment permit.

7-33. Forms of Maneuver

a. The field army employs each of the forms of maneuver to gain an advantage over the enemy, to close him, and to destroy him. The commander may orient his attack on the front or flank of the enemy. To accomplish this, there are three basic forms of offensive maneuver: the penetration, the frontal attack, and the envelopment. The double envelopment and the turning movement are variations of the envelopment. Infiltration is a technique of movement that may be used with all forms of maneuver and all types of offensive operations. Paragraph 8-28, FM 61-100, and FM 100-5 provide additional discussion of the forms of maneuver.

b. The distinction in the forms of maneuver exists primarily in the intent of the field army commander because, in most offensive operations, all or a combination of the forms of maneuver are used; e.g., a field army penetration may well entail envelopments by its subordinate elements.

c. These forms of maneuver generally are the same as those at lower levels. However, normally only field army and corps use the frontal attack. The division normally does not conduct a frontal attack except as a part of a corps or army operation.

d. The field army rarely specifies the form of maneuver for corps' adoption. The mission assigned to the corps, zones of action, and the allocation of combat power may impose such limitations as to the time and direction of attack that there is little choice of the form of maneuver to be adopted.

7-34. Field Army Reserve

a. The field army normally establishes a reserve of maneuver elements and fires to influence the action at critical times and places. The retention of a reserve permits the field army commander to influence the battle through the application of additional combat power. He may commit the reserve to accelerate the advance and to provide continuity of effort. The reserve also assists in providing security of flanks and rear.

b. In nuclear operations, nuclear weapons are a major element of the reserve. The discussion in paragraphs 7-13 and 7-14 relative to nuclear weapon employment is applicable.

c. The field army commander positions the maneuver element of the field army reserve to best influence the action. Time and space factors are major considerations in the positioning of larger unit reserves.

d. The maneuver element of the field army reserve may include divisions, separate brigades, or armored cavalry regiments.

e. The field army reserve may be the reserve of one or more corps with specific restriction on the corps' use.

7-35. Employment of the Field Army Reserve

In an offensive operation, the field army employs its reserve by releasing it to a corps. Corps commits the reserve element and assigns its mission. Exceptionally, the field army commander may directly control the employment of the reserve. The primary factor favoring this mode of employment is the commitment of

all corps headquarters to operations where time and space factors do not favor the assignment of a mission involving the use of the reserve. Field army contingency plan for employment of the reserve normally designate the forces that are to reconstitute the reserve.

7-36. Meeting Engagements

a. A meeting engagement is the combat action that occurs when a moving friendly force, incompletely deployed for battle, engages a static or moving enemy force about which the friendly force has inadequate intelligence. The action ceases to be a meeting engagement when the enemy situation has been developed and subsequent planned and coordinated operations are undertaken.

b. The mobility of current and projected tactical units of the field army and the range and lethality of modern weapons are conducive to highly mobile warfare with combat units dispersed laterally and in depth. Under these conditions, meeting engagements may occur frequently at lower echelons of command.

c. Except at the onset of hostilities in a theater of operations, the field army of the corps rarely needs to gain contract. The improved reconnaissance and intelligence gathering means available at field army, corps, and division provide the commanders with information at least as to the general location of major enemy formations.

d. The reserves of a field army or a corps on the defense may have to locate and attack enemy columns that have penetrated friendly rear areas. Counterairborne or counterairmobile operations by the field army reserve or corps reserve may result in meeting engagements.

e. FM 61-100 contains the details of the conduct of division operations in meeting engagements.

7-37. Exploitation and Pursuit

a. Exploitation is an operation designed to take advantage of gains by a successful attack. The attacker drives deep into the enemy's rear to destroy his means to reconstitute an organized defense or to initiate an orderly retrograde movement.

b. The pursuit is the final phase of the exploitation. Its goal is annihilation of the enemy force. The attacker can accomplish this goal by maintaining direct pressure on the withdrawing enemy and by intercepting and destroying the main enemy force. Although the attacker may have a designated terrain objective, the enemy force itself is the primary objective.

c. While smaller units may exploit local successes within the framework of their current operations, the field army plans operations to reduce the relative enemy combat power to permit exploitation and pursuit deep into the hostile rear with decisive results. Units may start the exploitation as a result of successes achieved during the progress of an offensive

operation, or they may launch it from a defensive position when counterattacks have created the opportunity. In either event, the field army commander should fully apprise corps if he intends to set the stage for exploitation followed by the pursuit during the course of an operation. Such guidance permits corps to plan and dispose its forces to this end.

d. Field army allocates combat and combat support units to the corps for exploitation and ultimately the pursuit operation. Field army remains no significant maneuver elements in reserve during the exploitation and pursuit. Normally in field army operations, the corps executes the exploitation and pursuit.

Section VIII. DEFENSIVE OPERATIONS

7-38. General

a. Paragraphs 7-10 through 7-20 discuss the means available to the field army commander for conducting defensive operations, together with the general principles or procedures for employing these means in each type of operation. This section covers certain aspects of planning and conducting field army defensive operations and should be weighed in conjunction with the general operational considerations outlined in paragraphs 7-10 through 7-20. Discussion of offensive missions to the corps as outlined in paragraph 7-30 is equally applicable to defensive operations.

b. Defense is a basic form of combat in which the purpose is to prevent, resist, repulse, or destroy an enemy attack. The field army conducts defensive operations to develop more favorable conditions for subsequent offensive operations, to deny the enemy entrance into an area, to reduce the enemy combat capability with minimum losses to friendly forces, to trap or destroy hostile forces, or to provide an economy of force measure.

c. In the defense, the field army commander seeks to force the enemy to react in conformity with his defense plan. When possible, he employs offensive operations to exploit enemy weakness and errors. The commander gains initiative by selecting the battle area and by

taking every opportunity to destroy enemy forces.

7-39. Defensive Planning

a. In field army planning for defensive operations, the field army commander normally selects a course of action employing all corps in the forward defense area. He provides the preponderance of available field army maneuver units to the corps.

b. Based on the selected course of action, the commander and his staff analyze the key terrain and the enemy avenues of approach. They determine corps missions, designate corps sectors, and allocate combat power. (The term "sector" used in defensive operations denotes area and is called zone of action in offensive operation.)

7-40. Forms of Defense

a. The field army conducts a defense by employing corps in a mobile or an area defense in the forward defensive area and assigning a definite sector to each corps.

b. Paragraphs 8-31 through 8-40 contain a discussion on corps defensive operations.

c. FM 100-5 contains a discussion on the principles involved in the conduct of the defense.

d. FM 61-100 provides a discussion on special considerations in the defense against

armor, airborne, airmobile, and mechanized forces.

7-41. Defensive Echelons

Defensive echelons include the security echelon, the forward defensive echelon, and the reserve echelon. The commander allocates forces and fires of the field army to each echelon in accordance with the field army defense plan.

7-42. Security Echelon

a. The security echelon begins at the forward edge of the battle area (FEBA) and extends to whatever distance to the front and flanks that security elements are employed. Forces operating under field army control in this area normally perform air surveillance and flank security missions. Normally a corps controls the covering force; exceptionally, however, field army may control the covering force.

b. When field army directs corps to establish covering forces to the front, field army designates initial coordinating points. The corps is responsible for the composition of the covering force, the details of coordination, and its operations. The field army normally prescribes the period that the covering forces are to hold the enemy forward of the FEBA.

c. The establishment of a defensive position when in contact with major enemy forces usually prevents the establishment of the covering force.

7-43. Forward Defensive Echelon

a. The forward defensive echelon extends rearward from the FEBA to include the area organized by the forward committed units. As an independent force, the field army has great latitude in selecting the areas for conducting the defense. As a part of a larger force, the field army conducts defensive operations in conformance with the instructions from higher headquarters. The field army describes the general trace of the FEBA through the designation of corps coordinating points.

b. The selection of the coordinating points between the corps on the FEBA and the designation of boundaries fix the corps defensive sectors. The analysis of the missions assigned

to the corps and an evaluation of the terrain, the enemy capabilities, the capabilities of the friendly units in the area (principally the divisions and the armored cavalry regiment), the composition of enemy forces, and the future plans of the field army primarily determine the sectors. For example, the requirement to resume the offensive at an early date may have a major bearing on the assignment of sectors and allocation of forces to the corps.

c. The designation of boundaries establishes the limits of each corps sector. In establishing boundaries, the field army commander assigns the responsibility for each major avenue of approach to a single corps. At field army, an avenue of approach permits the unrestricted maneuver of the major combat elements of one or more division-size units. The commander is careful to insure that the area assigned to the corps can provide room for the execution of the corps tactical plans. The maneuver room and the communications network available to each corps may be as important as the terrain itself.

7-44. Reserve Echelon

The field army normally establishes a reserve of maneuver elements and fires, combat support, and combat service support usually located behind the forward defensive echelon, e.g., the corps rear boundary to the army rear boundary. Uncommitted reserve echelon troops under field army control and located in the field army service area may have a secondary mission in support of FASCOM rear area security missions of the RAP operation (para 7-23). In nuclear operations the field army may rely primarily on nuclear weapons as a decisive element of the reserves.

7-45. Allocation of Combat Power

a. The field army allocates combat, combat support, and combat service support means to the corps based on an analysis of what each corps requires to accomplish its assigned mission.

b. In determining the allocation of means to the corps, the field army visualizes how each corps can defend its assigned sectors. An analysis of the capabilities of the divisions for defense in the type of terrain involved provides

this visualization. The actual disposition of the corps troops, both assigned and attached, is the corps' responsibility. The field army commander's concept of the employment of combat means is essential to the soundness of the planned allocation of combat power.

c. Because of the limitations on available forces or the assignment of extended frontages, the commander may have to examine in detail the terrain and the enemy capabilities to determine both where the defense needs strength and where it can economize.

7-46. Defense Operations During Employment of Nuclear Weapons

a. Discussion in paragraphs 7-32 and 7-49 apply to defensive operations during employment of nuclear weapons.

b. Current and planned defensive operations govern dispersion of field army tactical units, control elements, and combat service support installations. Dispersion required by the hostile nuclear environment invites defeat in detail. The factors of dispersion, mobility, vulnerability, and tempo of operations affect the organization and planned defensive operations. Combat forces in the defense, as in the offense, tend to operate as smaller units, semi-independently under mission-type orders. Communications in the dispersed, nuclear environment may become critical for command and control by the commander.

7-47. Employment of the Field Army Reserve

a. The field army normally does not employ the reserves under its own control or develop the detailed tactical plans for use of the reserve. The corps fight the tactical battle; therefore, field army determines when and where to release all or part of the field army reserve to the corps. Paragraph 7-44 discussed composition of the reserve.

b. The field army may release all or part of the reserve before the battle is joined, before penetrations occur in corps sectors, after penetrations occur in corps defensive sectors, or after the corps have committed part or all of their reserve.

c. The release of all or part of the army re-

serve before the battle is joined or before penetrations occur in the corps sectors is based on updated intelligence as to the size of the enemy force confronting the corps. If the enemy force is beyond the capability of the corps, based on initial allocation of combat power from field army, additional combat power from the field army reserve is released to the corps. Also, if nuclear or conventional firepower has destroyed certain elements of the corps before they join the battle or before the occurrence of a penetration, releasing part of the field army reserve to the corps may be necessary.

d. The field army determines, in priority, penetrations that may occur in the corps sectors that require release of all or part of the army reserve. Corps visualize penetrations with which they can cope. Field army then plans to release part of the field army reserve for penetrations that are beyond corps' capability. Planning for these penetrations is accomplished in the following sequence:

(1) Field army visualizes penetrations that may occur and may require release of all or part of the army reserve.

(2) Field army disseminates information on each assumed penetration to the corps in whose area the penetration is visualized. Field army provides the corps with the assumed enemy strength in the penetration and that part of the field army reserve that it will release to the corps to use in destroying or ejecting the enemy force in the penetration. These penetrations may be in the corps forward defensive area, on the corps flank, or on the boundaries between corps. If the penetrations fall in the areas of two adjacent corps, field army adjusts the corps boundary and assigns one corps the entire responsibility for the penetration.

(3) Corps prepares the detailed counterattack plans for use of its own uncommitted reserve and includes the additional combat power released from the field army reserve.

(4) Field army reviews and analyzes each corps counterattack plan for conformity with the army defense plan. It resolves necessary changes with the corps.

(5) Field army integrates all assumed

penetrations into a priority list for the release of the army reserve to corps and assigns prior-

ities of each assumed penetration based on the degree of criticality to the field army defense.

Section IX. RETROGRADE OPERATIONS

7-48. General

a. A retrograde operation, a movement to the rear or away from the enemy, may be a voluntary action or a movement forced by the enemy. The basic purpose of a retrograde operation is to preserve the integrity of the command for future operations or to improve relative position. A well-planned and an aggressively executed retrograde operation can inflict significant casualties on the enemy with relatively small losses to U.S. forces.

b. Within a field army conducting a retrograde operation, a combination of the withdrawal, delay, and retirement is usually necessary, either simultaneously by adjacent units or by one type of operation developing into another.

7-49. Nuclear Weapon Employment

Various echelons concerned with retrograde operations concurrently prepare plans for the tactical employment of nuclear weapons. Plans for withdrawal or delaying action include specific instructions necessary to insure integrated and detailed nuclear fire planning to include friendly nuclear strike warnings. The planning includes restrictions on use of ADM. Revision of the scheme of maneuver may be necessary to decrease vulnerability of key terrain positions in consideration of enemy nuclear capability. The commanders stress close contact and fast disengagement and emphasize mobile defensive techniques to deny relatively immobile targets to the enemy.

7-50. Field Army Role in Planning Retrograde Operations

a. Army group or higher headquarters may direct or initiate field army retrograde operations to preserve the integrity of the field army. When directing the operation, army group normally designates the next defensive position. Although plans may visualize a field army defense on one position until the offensive can be resumed, the commander considers

the possibility of enemy successes against the field army defensive position. Accordingly, the commander normally selects successive positions for defense and develops contingency plans for a sequence of retrograde movements to and defense of these positions.

b. The principles outlined in paragraphs 8-9 through 8-21 and in paragraphs 8-31 through 8-40 apply in planning the field army defense. In developing the task organization for the defensive operations, field army makes minimum changes in the corps force structures in effect for the retrograde movement. Such action simplifies corps planning and execution of the retrograde operations and facilitates occupation and organization of the new defensive position.

c. Field army prescribes the time when the retrograde operation begins and the time when the corps are expected to close into the new defensive position. Field army designates lateral boundaries for each corps from the initial defensive position to each succeeding defensive position. Field army provides each corps sufficient maneuver room and road nets to execute its tactical plans. Field army may prescribe the use of phase lines for control and coordination during the execution. Barrier coordination between corps is accomplished locally with information furnished to field army.

d. Each corps receives the forces necessary to accomplish the mission that the field army assigns. The bulk of combat and combat support units are attached to the corps, with little remaining under field army control. Close air support of retrograde operations is provided to the field army in accordance with the procedures outlined in paragraph 7-16.

e. Field army planning for a retrograde operation provides for adequate combat service support, the evacuation of supplies and equipment, and the prompt evacuation of casualties. Planning traffic and movement control is a major field army responsibility. Once field army begins a retrograde movement, it takes immediate action to limit the forward move-

ment of supplies and to reduce the level of supplies in the field army supply points by attrition or evacuation of excesses. Field army issues specific instructions limiting the destruction of supplies and equipment and fixing the responsibility for such destruction. It also acts to establish supply points in the new defense area. Engineer units under field army control improve the main routes of withdrawal, construct bridges at critical points, or begin preparation of the new defensive position. In planning the support of the retrograde operation,

close coordination with corps is required to insure adequate combat service support for the corps tactical plans with minimum loss, destruction, or unnecessary movement of supplies.

7-51. Execution

The field army's role in planning and executing a retrograde operation is largely limited to the actions described in paragraph 7-50. The corps is the agency of execution. Chapter 8 discusses the corps' role.

Section X. SUPPORTING OPERATIONS

7-52. Tactical Cover and Deception

a. Large-scale operations under conditions of general war are normally joint and strategic. The theater commander develops strategic deception plans to support these operations. He may direct tactical cover and deception to support the strategic deception plan. Tactical deception operations frequently require coordination with other Services as well as with allied commanders. Deception, except the ruses, which are conducted by combat units as described by FM 61-100, is strictly controlled to insure compliance with national policies.

b. Tactical cover and deception support tactical operations. Properly conceived and employed, cover and deception deceive the enemy as to the true dispositions, capabilities, and intentions of friendly forces, thus causing him to react advantageously to the friendly forces. Cover includes special measures designed to provide security to a plan, operation, or activity as well as to intensify normal security and passive defense measures. Deception is an activity designed to mislead the enemy by manipulating, distorting, or falsifying evidence.

c. The field army executes tactical cover and deception measures that higher headquarters assign. Tactical cover and deception planning is a normal staff activity; however, temporary planning groups may plan certain cover and deception operations. Plans may include the employment of specifically trained and organized units as well as the use of regular combat, combat support, and combat service support units in cover and deception operations.

d. Deception plans provide sufficient time for the enemy to receive the deception story, analyze the pattern of U.S. activities, and react in a manner previously determined as prejudicial to his interests. The accomplishment of planning and the initiation of the deception operation need to be early enough to give the enemy time to react at the time desired. Tactical cover and deception require strict security measures with very limited dissemination of plans and information. Tactical cover and deception plans are developed concurrently with operation plans.

e. FM 31-40 covers tactical cover and deception operations.

7-53. Denial Operations

a. A denial operation includes actions to prevent or hinder the enemy's use or benefit from areas, personnel, facilities, or materiel. It may include destruction, removal, contamination, or erection of obstructions.

b. Subject to the limitations imposed in directives from higher authority, a theater commander may conduct denial operations as a part of his overall campaign. The theater commander establishes the policy governing denial operations. His denial policies provide information on specific targets and types of items to be denied, the degree of denial desired, the priority of preparation and execution, and the subordinate commander who is responsible for planning and execution. (Normally, the Army component commander and the joint force commanders have the major share of responsibil-

ity for planning and executing denial operations.)

c. Below theater, the commander issues instructions for denial operations as an annex to a letter of instructions (LOI). Based on the type and significance of the denial targets involved, the army group commanders determine those targets that units under their direct control will destroy and those that subordinate units will destroy.

d. At field army and below, commanders combine applicable portions of the strategic denial plan of higher headquarters with the barrier plan into a single, comprehensive, coordinated plan and publish it in the barrier and denial annex to the operation order. The plans are consolidated because most denial targets are executed by construction, destruction, or contamination—all of which technically are similar to or identical with the work of preparing barriers.

e. FM 31-10 discusses denial operations in detail.

f. The doctrine and guidance to be followed in emergency denial of nuclear weapons are contained in FM 6-20-1.

7-54. Barriers

a. Barriers are a coordinated series of natural and artificial obstacles employed to delay or stop the movement of an opposing force and to enable friendly forces to impose additional losses in personnel and equipment on the opposing force. A barrier normally links obstacles in a linear form. It is not always an impenetrable line of great depth and continuous strength.

b. Commanders at each echelon have authority to make full use of natural and artificial obstacles for security and for the strengthening of close-in defenses. Corps and higher commanders have the authority to direct the employment of barriers on an extensive scale. This authority may be delegated to division commanders. The basic principle involved in the employment of barriers is their use to augment the combat effectiveness of available forces. Barriers are not a substitute for troops and weapons; but if properly employed, barriers materially increase the effectiveness of

troops and weapons. Barriers are comprehensively integrated with the overall tactical scheme of maneuver, the fire support plan, and the combat service support plan.

c. Barriers are used in the offense—

- (1) To contribute to flank security.
- (2) To impede counterattack.
- (3) To assist in enemy entrapment.

d. Barriers are used in the defense—

- (1) To delay the enemy advance toward the front or flanks.
- (2) To delay or limit the movement of a penetrating or enveloping force.
- (3) To canalize enemy movement into areas where he can be defeated or destroyed.
- (4) To separate enemy armor from infantry.

(5) To provide additional protection for a lightly manned section of the forward defense.

e. Barriers are used in retrograde operations—

- (1) To impede the enemy advance.
- (2) To permit the adoption of economy of force measures.
- (3) To gain time.

f. Army groups and higher headquarters prepare broad barrier studies based on studies of the weather and terrain. They issue instruction, based on these studies for the planning and employment of barriers.

g. At field army and corps, barrier plans are a normal part of operational planning. Field army or corps barrier plans are part of the tactical plan and are issued as an annex to the operation order. The field army barrier plan is not a detailed plan showing the individual obstacles in the field army area. It is a framework around which the corps can develop plans.

h. Applicable portions of the field army barrier plan are included in the corps barrier plan. The same type of instructions contained in the army plan are included in the corps barrier plan, but the latter is more detailed and covers the location of those natural and artificial barriers including atomic demolitions and barrier minefields essential to the corps tactical plan.

i. FM 31-10 covers barrier planning in detail. Use of ADM is discussed in FM 5-26.

7-55. Unconventional Warfare

a. The theater commander conducts unconventional warfare (UW) in his area of operations. As a part of this responsibility, he designates operational areas for the conduct of unconventional warfare and related unconventional warfare activities.

b. The principal U.S. Army element available to the theater commander to organize unconventional warfare operational areas is the special forces group, which normally is assigned to theater army.

c. A theater unconventional warfare command, may be established as a subordinate unified command by the theater commander; it provides joint planning and coordination for unconventional warfare operations. The Army component of the theater unconventional warfare command, a special forces group, establishes the required special forces operational base (SFOB) in friendly territory. The group

plans for, directs, controls, and supplies U.S. special forces operating in denied or hostile areas in organizing, training, equipping, and controlling irregular forces in unconventional warfare, a ground operation, and such other unconventional warfare operations as may be required in assigned operational areas.

d. When unconventional warfare operational areas come within the area of influence of the advancing tactical command, operational control of unconventional warfare forces in these areas normally transfers from the unified or specified command level to the field army concerned. The field army, in turn, may assign operational control of the unconventional warfare forces to any of the subordinate tactical units. Control normally is not delegated below division.

e. FM 31-21 and FM 31-21A provide detailed discussions of the employment of special forces in support of unconventional warfare.

Section XI. INDEPENDENT AND SEPARATE CORPS

7-56. Definition

a. A corps may be a major subordinate command of army group or of theater army. When performing such a role, corps becomes either an independent corps or a separate corps. A corps employed in these roles normally receives its mission from the theater army; the army group; or, exceptionally, the field army. It may function as a part of a joint task force, unified or combined command.

b. The independent corps operates far removed from the field army. It is similar to a theater army in that it normally has area responsibilities encompassing theater base functions.

c. The separate corps, similar to a field army, normally operates adjacent to but apart from the field army.

7-57. Composition and Functions

a. The corps is primarily a tactical unit of execution with limited combat service support responsibilities and capabilities. Its employment in a role independent of or separated from the support normally provided by field

army requires changes in the composition and functions usually associated with the corps.

b. The corps headquarters is relatively small, is tactically oriented, and cannot function indefinitely without augmentation, particularly in the combat service support field. The corp, operating independently or separately, is, therefore, responsible for its own combat service support. The independent or separate corps is provided a corps support command (COSCOM) on the basis of one COSCOM assigned per independent or separate corps force. The COSCOM supporting a separate corps provides services similar to those a FASCOM provides to a field army. For an independent corps the COSCOM of a separate corps is increased by adding theater base units of the theater army support command. The corps headquarters staff, when operating independently or separately, may require expansion in areas concerned with combat service support. Additional signal communication units are required to support their operations. Paragraph 7-59 provides a discussion of the COSCOM.

c. The principles concerning field army tacti-

cal and combat service support operations discussed in this chapter apply to both the independent and the separate corps. The discussion of corps in chapter 8 also applies to corps employed independently and separately.

d. Employment of the independent corps in a cold war stability operation typifies an operation for which the independent corps may be structured (para 7-26 through 7-27).

7-58. COSCOM

a. The COSCOM assigned to the independent corps has as its nucleus a support brigade of the FASCOM that assumes the role of a FASCOM. The support brigade's augmentation consists of sufficient FASCOM- and TASCOM-type combat service support elements (para 4-17 and 4-18) to enable the corps to conduct inde-

pendent operations. COSCOM is responsible to the independent corps force commander for all combat service support and, as required, theater base activities. Headquarters, COSCOM, is active in operations performing normal staff functions, developing plans, computing requirements, and exercising control of combat service support activities through control centers similar to those located within the FASCOM and the TASCOM. FM 54-3 provides discussion of the COSCOM.

b. The COSCOM in support of a separate corps has as its nucleus a corps support brigade of the FASCOM. The support brigade's augmentation, however, normally is limited to FASCOM-type units and additional staff elements to enable the separate corps to accomplish its mission. Combat engineer elements of the tactical force provide construction support.

CHAPTER 8 CORPS

(STANAG 2099 and SEASTAG 2099)

Section I. GENERAL

8-1. Introduction

This chapter refers to a U.S. corps operating as part of a U.S. field army. An independent or separate corps operating under the direction of a joint task force or combined force headquarters will follow the principles discussed herein. Paragraphs 7-56 through 7-58 provide a discussion of independent and separate corps.

8-2. Organization

a. The corps, a task force of combined arms and services, is a tactical unit of execution. Its composition is not fixed; however, the TOE 52 series establishes the organization of the corps headquarters and headquarters company. Some units habitually are assigned to provide the means needed to facilitate command and control (fig. 8-1). The field army assigns or attaches units to the corps. The type and the number of troop units assigned or attached to the corps depend on the mission, the characteristics of the area of operations, the availability of units, the enemy situation, and the type of operations contemplated. The corps organization permits great flexibility since the field army organizes it for a specific tactical mission.

b. The corps may contain allied units. This chapter specifically discusses a corps composed entirely of U.S. units; however, the principles are applicable to a corps composed of both U.S. and allied units.

c. The overall combat power of the corps is not restricted to that provided by attached or assigned field army units. Operations of supporting field army units and elements from other Services frequently strengthen the corps combat power.

8-3. Corps Headquarters and Staff

a. TOE 52-1 provides the organization for the headquarters of a corps. When engaged in combat operations, the corps headquarters usually consists of one main echelon organized as the main command post and an alternate command post. It may establish a tactical command post if required. When employed as an independent or separate corps, a rear echelon may be required. The rear echelon is primarily concerned with combat service support provided by the assigned corps support command (COSCOM). FM 101-5 contains a detailed discussion of the echelonment of headquarters.

b. Corps headquarters uses the same organization as the U.S. Army general staff (FM 101-5).

8-4. Corps Tactical Operations Center

The establishment of a corps tactical operations center (CTOC) may be necessary to assist the corps commander in reducing staff reaction time and coordinating current operations to insure sound command decisions and their rapid implementation. FM 101-5 provides detailed discussion of the CTOC.

Section II. PLANNING

8-5. General

a. The corps fights the tactical battle for the field army. The field army commander provides

the corps commander all the necessary combat and combat support units required to conduct a successful tactical operation. At the same time,

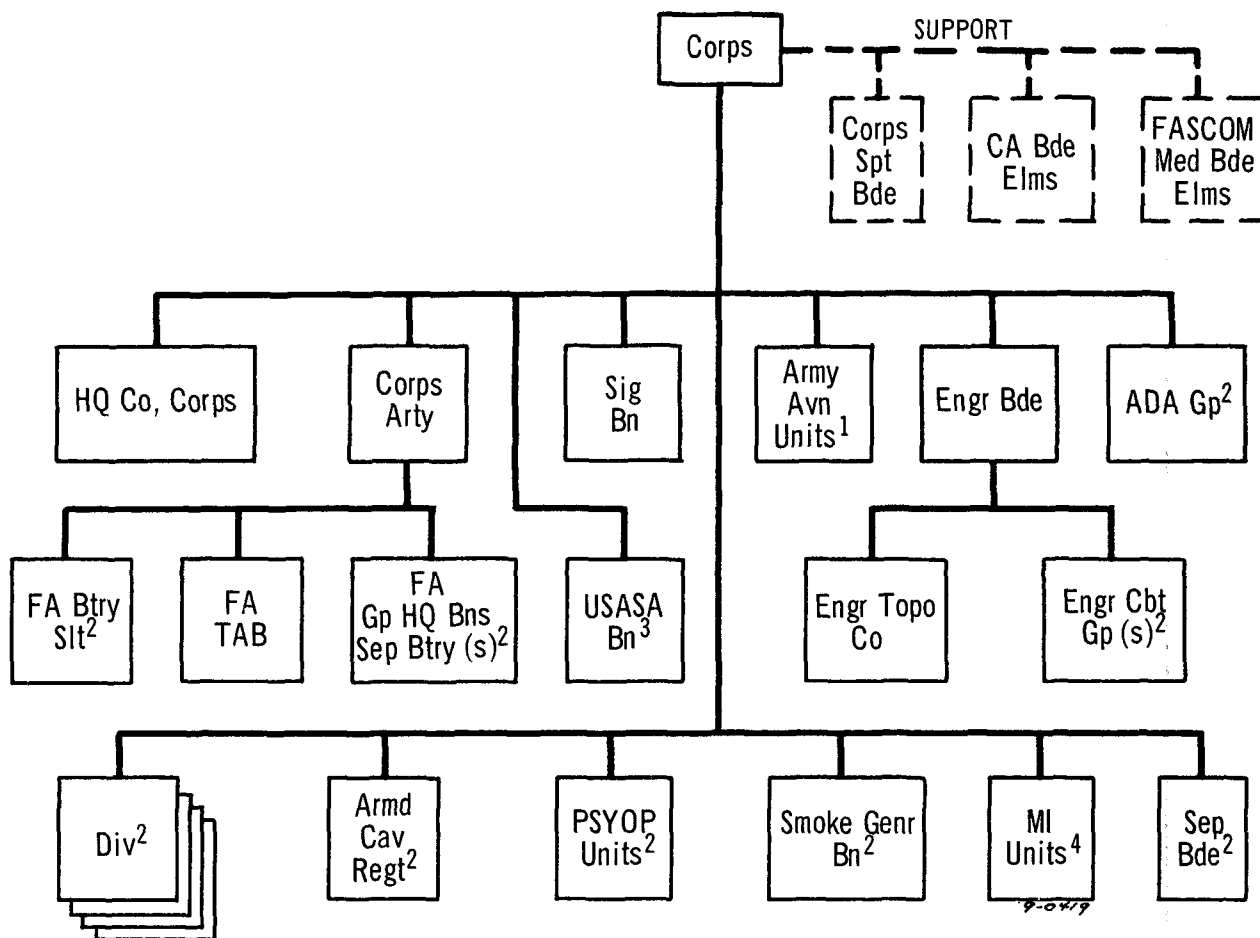

LEGEND

----- FASCOM organization for corps combat service support.

- ¹Aviation co assigned to corps. Other elms attached as required.
- ²Attached as required.
- ³Provides support in accordance with AR 10-122.
- ⁴Attached.

Figure 8-1. Typical corps organized for combat on a large landmass.

the field army commander retains responsibility for providing combat service support to the corps and for other things that the corps commander does not *immediately* require to wage the tactical battle. When the corps is employed in an independent role or as a separate corps, a field army support command (FASCOM) corps support brigade is assigned and forms the nucleus of the COSCOM. This brigade, aug-

mented as required, becomes the COSCOM to provide corps combat service support.

b. Field army plans are the bases for corps planning of tactical operations. Corps plans project well into the future; therefore, the corps commander and his staff receive timely information of field army contemplated operations. Corps' receipt of such information is necessary for development of effective and de-

tailed plans and for adequate preparation by units making up the corps. Likewise, the commanders and staffs of the major subordinate units of the corps keep informed of contemplated corps operations.

c. The corps conducts combat operations for the current phase of a field army operation and simultaneously prepares the detailed plans for at least the next phase. As the situation permits, corps planners commence planning for subsequent phases.

d. The corps commander must have adequate and timely information of the enemy to make maximum use of his forces and to plan their proper employment. When necessary, field army and adjacent corps provide specific intelligence. Intelligence, reconnaissance, and surveillance agencies assigned and attached to the corps vigorously develop the enemy situation. Information and intelligence of interest to subordinate commanders is transmitted to those commanders without delay. In addition to the information that is of value to specific elements, each major subordinate commander keeps advised of the situation and the current enemy capabilities by means of intelligence estimates, reports, and situations maps. Liaison officers at field army, division, and adjacent corps are particularly valuable in exchanging such information.

8-6. Command and Staff Actions

a. Although the missions assigned to the corps are more specific than those assigned to the field army, they are relatively broad in scope. The corps commander analyzes the mission and states his planning guidance and concept of operation. The staff develops courses of action to accomplish the specific task assigned by field army as well as the implied tasks developed in the mission analysis. The corps commander's decision and concept of operation provide the basis for the development of the detailed corps plan. Once the plan has been implemented and the corps units have been com-

mitted, radical changes in the scheme of maneuver should be avoided. Adjustments in fire support can readily be made, but changes affecting the planned movement of corps maneuver forces require adequate consideration of time and space factors. The timely and effective employment of corps units results from decisions made early enough to permit thorough coordination and planning. The higher the echelon of command, the earlier the commander makes a decision and the fewer the changes that can be made.

b. The sequence of actions in the decision-making process at corps is thus similar to that at field army, and the discussion in paragraph 7-7 generally applies. The overall process at corps, however, is less formal than at field army.

8-7. Phasing a Corps Operation

The corps phases its operations under the same general conditions as the field army. The discussion concerning phasing in paragraph 7-8 applies to the corps, scaled down in scope as appropriate.

8-8. Scope of the Corps Operation Order

a. The corps operation order prescribes the details of one or more phases of the corps operation and provides outline instructions for the succeeding phases. Corps normally implements a succeeding phase by publishing a complete operation order or a fragmentary order. The principles outlined in paragraph 7-9 apply.

b. The concept of operation and the assignment of tasks permit the subordinate units to execute at least one phase and to initiate planning for at least one additional phase. The concept of operation describes the tactical plan to accomplish the mission that corps is to execute. The assignment of specific tasks to subordinate units is for one or more phases. Other tasks are assigned on a "be-prepared" basis as they can be foreseen.

Section III. OPERATIONAL CONSIDERATIONS

8-9. General

The field army assigns or attaches most of its combat and combat support units to the corps

for the conduct of combat operations. The corps commander may further attach some of these units to the division, or he may employ

the units under corps control to support the divisions in accordance with the unit's capabilities and division's requirements. Primary consideration goes to the division making the corps' main effort. This section discusses the combat and combat support units attached or assigned to the corps to include the general method of their employment. Support from other Services is also treated. When operating in a nuclear environment, the corps may have to increase its dispersion, both laterally and in depth. The requirement to mass for attacks and to disperse after the attack magnifies problems in command and control, coordination, combat support, and combat service support. Because of the requirement for dispersion, the corps defends a wider frontage than in a nonnuclear environment to preclude presenting lucrative targets for the employment of enemy nuclear weapons.

8-10. Maneuver Units

a. Divisions. The field army commander assigns or attaches divisions of all types to the corps in various combinations to organize the corps for a particular mission or operation. Field army assigns or attaches from two to six divisions to each corps. Divisions, particularly airborne and airmobile divisions in an infantry division role, require augmentation for almost any type of operation. Most of the combat and combat support units assigned to the field army are attached to the corps; therefore, the corps provides the necessary support required to augment the combat power of the divisions. FM 61-100 covers division operations.

b. Armored Cavalry Regiment. The armored cavalry regiment performs reconnaissance and surveillance and provides security for the corps. The regiment, through its assigned armored and air cavalry units, can operate over a wide area and at extended distances and may serve as a flank or rear area security force. The regiment may also engage, when properly reinforced, in offensive, defensive, or delaying actions as a part of the main battle or serve in an economy of force role. One armored cavalry regiment normally is attached to the corps. This regiment can operate under corps control or be attached, in whole or part, to a division.

FM 17-95 contains guidance for employment of the regiment.

c. Separate Brigade. A separate brigade headquarters may be attached to the corps. Infantry, mechanized infantry, airborne, or tank battalions are attached to the brigade headquarters for command and control. The brigade with its attached battalions may work directly under corps control, perform a rear area or flank security mission, serve in the corps reserve, or augment combat power of one of the divisions.

8-11. Fire Support

a. Fire Support. Paragraph 7-12 contains a discussion on fire support at field army level.

b. General. Fire support means under corps control include the nuclear and nonnuclear fires of attached surface-to-surface and surface-to-air weapon systems. Tactical air support is available from the Air Force and/or frequently from the Navy and Marine Corps. Under some conditions, naval gunfire support is also available.

c. Field Artillery. The bulk of the field artillery battalions assigned to the field army are attached to the corps, thus placing under the corps commander a powerful means of influencing the course of combat.

(1) Corps artillery provides depth to combat; augments the fire support provided by divisional artillery; and provides the bulk of fires on hostile cannon, missiles, and rockets. In addition, it performs corps-wide target acquisition functions.

(2) Corps artillery controls the operations of nondivisional field artillery and coordinates the activities of the artillery with the corps. Corps coordinates and practices large-scale employment of artillery; it brings into play the bulk of the medium and heavy artillery, the longer range rockets and missiles, and its nuclear capability. The corps commander accomplishes control and coordination by assigning tactical missions to subordinate units, attaching artillery to subordinate units, providing survey and communication to the artillery with the corps, and prescribing the available ammunition supply rate.

(3) Types of missions normally assigned

to corps artillery groups and battalions include *general support*, *reinforcing*, and *general support-reinforcing*. Corps artillery units may be attached to the divisions of the corps. The corps commander, on the recommendation of the corps artillery commander, may assign missions to the division artillery of a reserve division; but he makes provision to return the artillery to the control of its parent unit prior to its commitment. Artillery support is provided for nondivisional elements of the corps reserve when these forces are committed independently. The main attack of the corps is weighted with responsive artillery support.

(4) The nuclear delivery capability of field artillery weapons reduces the requirement for massed artillery fire during nuclear operations. Corps normally attaches corps cannon artillery and a portion of the shorter range missile units to an exploiting force.

(5) FM 6-20-1 and FM 6-20-2 contain detailed discussions of the employment of field artillery units.

d. Air Defense Artillery.

(1) In an independent operation, the corps commander may have responsibility for the air defense of the corps. The allocation of air defense units to the corps provides the means for discharging this responsibility. The forward area and low- and medium-altitude air defense artillery battalions are controlled through an air defense artillery group to accomplish the air defense of the corps area. The corps commander employs the air defense artillery groups attached to the corps as he desires and prescribes the priorities for air defense within the corps area.

(2) Coordination of air defense activities with other tactical operations of the corps is a normal staff activity.

(3) The division mission determines the requirement for attachment of air defense units to divisions. FM 61-100 contains a discussion of division employment of organic and attached air defense units.

(4) FM 44-1 contains a detailed discussion of air defense operations.

e. Army Aviation. Army aviation units may operate directly under the corps or field army to which assigned or may be attached to or

placed in support of subordinate elements for specific missions. Armed helicopters of these aviation units supplement and extend the fire-power available to the ground force commander from ground-based weapons and from close air support provided by other Services.

f. Fire Support Coordination Line.

(1) The fire support coordination line (FSCL) is used to coordinate supporting fires delivered by forces not under corps control, but that may influence current tactical operations. The corps commander establishes the FSCL in coordination with the fire support coordinator (FSCOORD), the supporting tactical air, and the commanders of other fire support means, based on the recommendation of subordinate commander.

(2) The FSCL is beyond the farthest point to which the commander normally sends patrols or penetration forces (including airmobile forces) or maintains covering forces. The FSCL should be easy to define on a map and easy to recognize from the air. When detached forces are beyond the corps FSCL, an all-round FSCL is established around the detached forces.

(3) Coordination is accomplished with the corps concerned prior to the use of fire support against targets within the corps area short of the FSCL.

(4) The complete details of agreement of STANAG 2099 are contained in FM 6-20-1.

8-12. Corps Functions in Nuclear Weapon Employment

a. Field army allocates nuclear weapons to the corps for a specific period, specific mission, or a phase of the field army operation. As at field army, the corps commander uses the allocation as a planning factor. The commander concerned must have additional authority for actual dispersion of allocated weapons to desired locations. Proper authority must authorize expenditure of these weapons (para 7-13).

b. The problems created by the introduction of nuclear weapons to the modern battlefield are particularly critical at corps. Corps accomplishes the detailed integration of nuclear weapons with the scheme of maneuver by allocating a portion of available nuclear weapons

to its major subordinate units, planning the employment of nuclear weapons to be fired by corps delivery means, and retaining an appropriate reserve.

c. In planning the employment of nuclear weapons, the corps commander takes into account the characteristics of the available weapon systems to include their range, responsiveness, reliability, accuracy, and the yields that the weapon system can deliver. Corps allocations to subordinate units frequently include weapons delivered by means not under control of the unit commander. To maintain a high level of responsiveness in nuclear weapon support, corps allocates divisions some nuclear weapons that delivery systems under the control of the divisions can deliver.

d. Corps insures appropriate dispersion of weapon and delivery systems.

e. Corps maintains current and complete information concerning the location and condition of readiness of nuclear weapons and delivery means available to corps.

f. Special ammunition units of the corps support brigade usually carry a portion of the corps' nuclear allocation; therefore, corps has an interest in their location. Corps recommends to the corps support brigade commander the successive location of these installations.

8-13. Allocation Procedure

a. The corps plans at least one operation in advance; it develops the plans well in advance of the actual beginning of the operation. Correspondingly, corps also develops the nuclear allocation to subordinate corps units in advance. The corps commander provides his staff with planning guidance on employment of nuclear weapons as well as guidance on employment of divisions and other major subordinate commands. FM 101-31-1 contains the nuclear weapon aspects of the corps commander's planning guidance. FM 9-6 contains details on ammunition unit operations in the field army.

b. In developing a firm or a tentative allocation, the corps staff estimates the number and the type of weapons scheduled for corps' delivery, for corps' retention in reserve, and for corps' allocation to the major subordinate units within those weapons that are allocated by

field army. The subordinate units are informed of the corps commander's concept of operation, their missions, and their tentative allocation of nuclear weapons and are requested to submit their nuclear weapon requirements. The corps staff reconciles these requirements with the availability of weapons and, on the corps commander's approval, announces the final corps' allocation.

8-14. Chemical and Biological Weapons

a. See paragraph 7-15.

b. Coordination of the employment of chemical and biological weapons to support corps operations is a normal staff activity.

8-15. Tactical Air Support

a. This paragraph covers the role of the corps in planning and conducting tactical air support operations; it should be considered in conjunction with paragraphs 6-9 and 6-10 concerning the role of army group and paragraph 7-16 concerning the role of the field army.

b. Close air support constitutes an integral part of the fire support available to the corps. Airlift provides air movement of troops and cargo. Air reconnaissance support provides the corps with the capability for deep reconnaissance of enemy-held territory. Air interdiction support provides attacks on unfriendly military forces at such a distance that detailed integration of each air mission is not necessary for friendly fires and friendly movements. Planning for air support from the tactical air force is closely integrated with corps planning for ground tactical operations.

c. Within the corps headquarters, planning and coordinating tactical air support operations are normal staff activities. The G3 and the G2 air of the corps coordinate close air support operations and air reconnaissance operations respectively.

d. Division forwards requests for pre-planned tactical air support missions to corps for processing through corps headquarters, assignment of priorities, corps commander's approval, and forwarding to field army (fig. 7-3).

e. The DASC normally is collocated with the CTOC. Minimum reaction time is insured

by having requests for immediate air support forwarded directly from the initiating unit to the DASC using the air force-operated air request net. The tactical air control post (TACP) at each headquarters monitors the net for the commander concerned. If an intermediate headquarters disapproves, the TACP notifies the DASC and the requester, and the request is canceled. If the commander at DASC or higher levels disapproves the request, the DASC informs the corps commander daily of the number of close air support sorties allocated to the corps. The corps commander may allocate these sorties to his subordinates. Subordinate commanders may suballocate the sorties. Ground commanders allocating, suballocating, or reallocating sorties will inform the DASC through the air liaison officer (ALO) of the TACP at their echelon in addition to normal notification through the chain of command (fig. 7-3).

f. FM 61-100 provides a discussion of tactical air support operations at division.

8-16. Armed Helicopter Fire Support

Army aviation units have organic armed helicopters that can provide direct aerial fire support for ground combat units. Aerial artillery units provide aerial artillery support. Procedures for requesting armed helicopter fire support are discussed in paragraph 7-17 and in FM 61-100.

8-17. Naval Gunfire and Naval Close Air Support

Naval gunfire and naval close air support are provided during amphibious operations and may be provided when supporting ships are within range of the target area. Naval fire support is integrated with other fire support available to the corps. Paragraph 7-18 provides discussion of naval fire support.

8-18. Electronic Warfare

The electronic warfare system provides the means of reducing the effectiveness of hostile electronic activities and insuring the effective use of friendly electronics. Discussion of electronic warfare and basic references is provided in paragraph 7-19.

8-19. Stability Operations

The field army commander directs the stability operations. The principles enumerated in paragraph 7-25 through 7-28, scaled down to corps, apply to corps operations in stability situations. FM 31-16, FM 31-22, FM 31-23, and FM 31-73 provide detailed information concerning employment of U.S. Army forces in stability operations.

8-20. Other Corps Combat Support

a. *Army Aviation.* Field army habitually attaches a portion of its Army aviation units to corps. These units provide the corps responsive aviation units to augment and support the ground units in their performance of the functions of combat. Infantry and airborne infantry divisions have an organic aviation battalion with the capability to lift a rifle company in a single lift. The airmobile division has the organic capability to simultaneously airlift the assault elements of two airmobile infantry battalions and three 105-mm howitzer batteries, or any combination thereof. The aircraft of the mechanized and armored divisions normally are for command and control. When the airmobile force to be lifted is larger than a rifle company, the infantry and airborne infantry divisions require the support of additional corps or army aviation units. Airmobile operations of larger size units require aviation support from corps or army. Corps provides Army aviation support to the divisions by placing units under the operational control of the division, assigning a direct support mission to the aviation unit, or attaching the aviation unit to the division for the duration of the operation or for a specific period. FM 57-35 contains a detailed discussion of airmobile operations.

b. *Chemical.* Chemical smoke generator units provide concealment for friendly troops, installations, and tactical areas under all operating conditions. Chemical smoke generator battalions normally are assigned to field armies or communications zone (COMMZ) and are further attached to corps or divisions for support of these units. FM 3-50 contains a detailed discussion of chemical smoke generator units and smoke operations.

c. *Engineer.* The primary mission of the en-

gineer brigade with its attached engineer groups, battalions, and separate companies is to strengthen the combat power of the corps by construction or destruction, with emphasis on facilitating friendly movement and impeding enemy movement. The engineer combat groups may be assigned an area responsibility, be placed in support of a division, be given a task assignment, or be attached to a division. The engineer combat groups usually are assigned an area responsibility. Recognizing that the divisional engineer battalion seldom can perform all engineering tasks necessary to support a division, an engineer combat group may have to support a division with elements of the group. Corps engineer units may be attached to the divisions for special operations. FM 5-142 contains a detailed discussion of nondivisional combat engineer units.

d. Signal. The corps signal battalion operates the corps communication system consisting of a command point-to-point voice and radio teletypewriter system and a multichannel system (FM 11-92). The corps commander uses the command system for control of corps tactical operations. The corps also has access to the field army area system as a backup for organic communications and to carry its combat service support traffic. Messenger service is used to transmit orders, overlays, bulky items, and other reports or messages not suitable for electronic transmission.

e. U.S. Army Security Agency. Normally a U.S. Army Security Agency (USASA) battalion with its subordinate units provides support to the corps to render that tactical support ef-

fort specified in AR 10-122. FM 32-10 provides a detailed discussion.

f. Long-Range Patrol Elements. Paragraph 7-20g contains a discussion of long-range patrol elements.

g. Psychological Operations. Normally, one psychological operations (PSYOP) company or detachment is assigned to corps as described in paragraph 7-20d. G3 has staff supervision of their operations. Each unit is organized to support the mission. Corps normally retains mobile radio and printing capabilities, while loudspeaker teams are attached to the forward divisions. FM 33-1 and FM 33-5 provide details of operations.

h. Military Intelligence. Field army habitually attaches a military intelligence detachment to the corps. This unit provides the corps intelligence functions requiring the employment of special skills and/or the utilization of foreign languages in support of a corps headquarters. FM 30-9 provides a discussion of intelligence support of corps operations.

8-21. Rear Area Protection

The corps commander is responsible for rear area protection (RAP) operations in his corps area. Units operating within the corps area normally are responsible for their own local security and area damage control efforts and for providing mutual assistance to adjacent units within their capability. These responsibilities are carried out in conformance with the plans and directives of the corps commander (para 7-23).

Section IV. OFFENSIVE OPERATIONS

8-22. General

Paragraphs 8-9 through 8-20 cover the means available to the corps for combat operations, together with the general principles or procedures for employing these means. This section treats the more important aspects of planning and conducting corps offensive operations and must be considered in conjunction with the operational considerations outlined in paragraphs 8-9 through 8-21.

8-23. Missions

The corps commander's decision and concept of operation are translated into missions for each division and other subordinate commands and are transmitted to these elements in the form of mission-type orders. The division's mission usually is more specific than the mission assigned to the corps. It may encompass the domination or neutralization of a terrain feature or a locality or the destruction of a hostile force.

8-24. Coordination and Control

The corps prescribes coordination and control measures to insure unity of effort. Lines of departure or areas from which the attack can be launched, time or times of attack, zones of action, axes of advance, or directions of attack are used by the corps as appropriate. Boundaries establishing the zones of action of each division are assigned. Key terrain and major avenues of approach are assigned wholly to one division. Phase lines and checkpoints are used as appropriate.

8-25. Nuclear Weapon Employment

a. Nuclear weapons, because of their destructiveness, permit the adoption of courses of action not feasible during nonnuclear operations; therefore, the corps commander gives the same detailed consideration to the employment of nuclear weapons that he gives to the employment of his major subordinate units. The employment of nuclear weapons is a major consideration of the commander's during the formulation of planning guidance.

b. The allocation of nuclear weapons to the major subordinate commands follows the same pattern as that of mission assignment; i.e., the commander allocates nuclear weapons to the divisions for one phase of the corps operation and provides an allocation for succeeding phases.

8-26. Advance to Contact

a. From the standpoint of the corps commander, the movement of his corps is a coordinated movement of the division and corps troops. While the advance of the various elements of the corps is coordinated, it does not necessarily follow that elements always move in a fixed relationship to each other. An advance to contact executed by a corps is, in essence, an advance to contact by the individual divisions of the corps; and it is coordinated and controlled by the corps. FM 61-100 covers division operations in a movement to contact.

b. In addition to coordinating and controlling the advance of the divisions, corps directs and controls the employment of corps security forces to the front and flanks of the advancing divisions. Tactical air reconnaissance and

Army aviation provide corps timely information of the movement and disposition of enemy forces that can influence corps operations. The corps commander then can make an early decision as to the employment of the elements of the corps.

8-27. Meeting Engagements

a. Paragraph 7-36 covers meeting engagements at corps and field army.

b. FM 61-100 covers division operations in meeting engagements.

8-28. Corps Offensive Maneuver

a. General. The corps in an offensive action employs the basic forms of maneuver—the penetration, the frontal attack, and the envelopment. After corps completes the offensive plan and the action starts, the corps commander controls the action through orders to the divisions and employment of nuclear and nonnuclear fires under his control. The divisions are the units of execution; the corps offensive action thus becomes a series of coordinated and integrated division engagements. The distinction in the corps form of maneuver exists primarily in the *intent* of the corps commander since the subordinate elements of the corps may use *all* the forms of maneuver in their attack.

b. Corps in a Penetration. The fundamentals of a penetration at corps are the same as at division. The corps attack passes through the enemy's principal defensive position, destroys the continuity of the enemy force, divides the enemy force, and defeats it in detail (fig. 8-2).

(1) The corps main attack is on a relatively narrow front and toward the corps objective. Preparatory fires assist in rupturing the enemy position and isolating the enemy forces directly opposing the main attack force. The supporting attacks widen the gap and prevent the enemy from disengaging. Corps may use nuclear fires with the supporting attacks.

(2) After rupturing the enemy's main defensive position, the corps main attack forces may continue the attack toward the corps objective, or the corps reserve force may pass through the initial main attack forces to secure the corps objective.

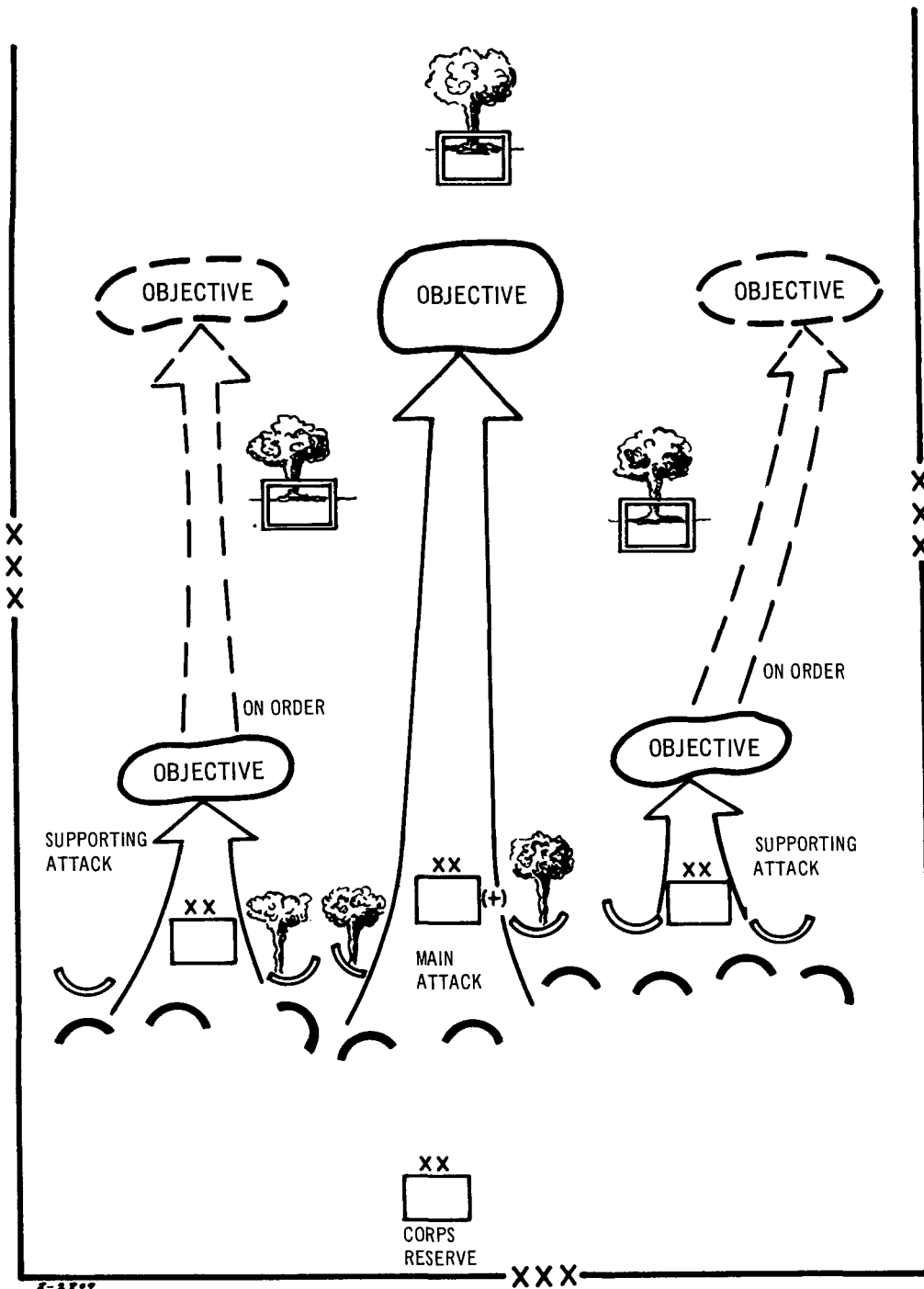

NOTE: Diagram is schematic only. Overlay techniques such as boundaries, phase lines, lines of departure, etc., are not shown.

Figure 8-2. Corps conducting a penetration.

(3) Nuclear fires delivered by corps long-range cannon and missile delivery systems,

supporting field army missiles, or tactical aircraft are employed against enemy reserves ca-

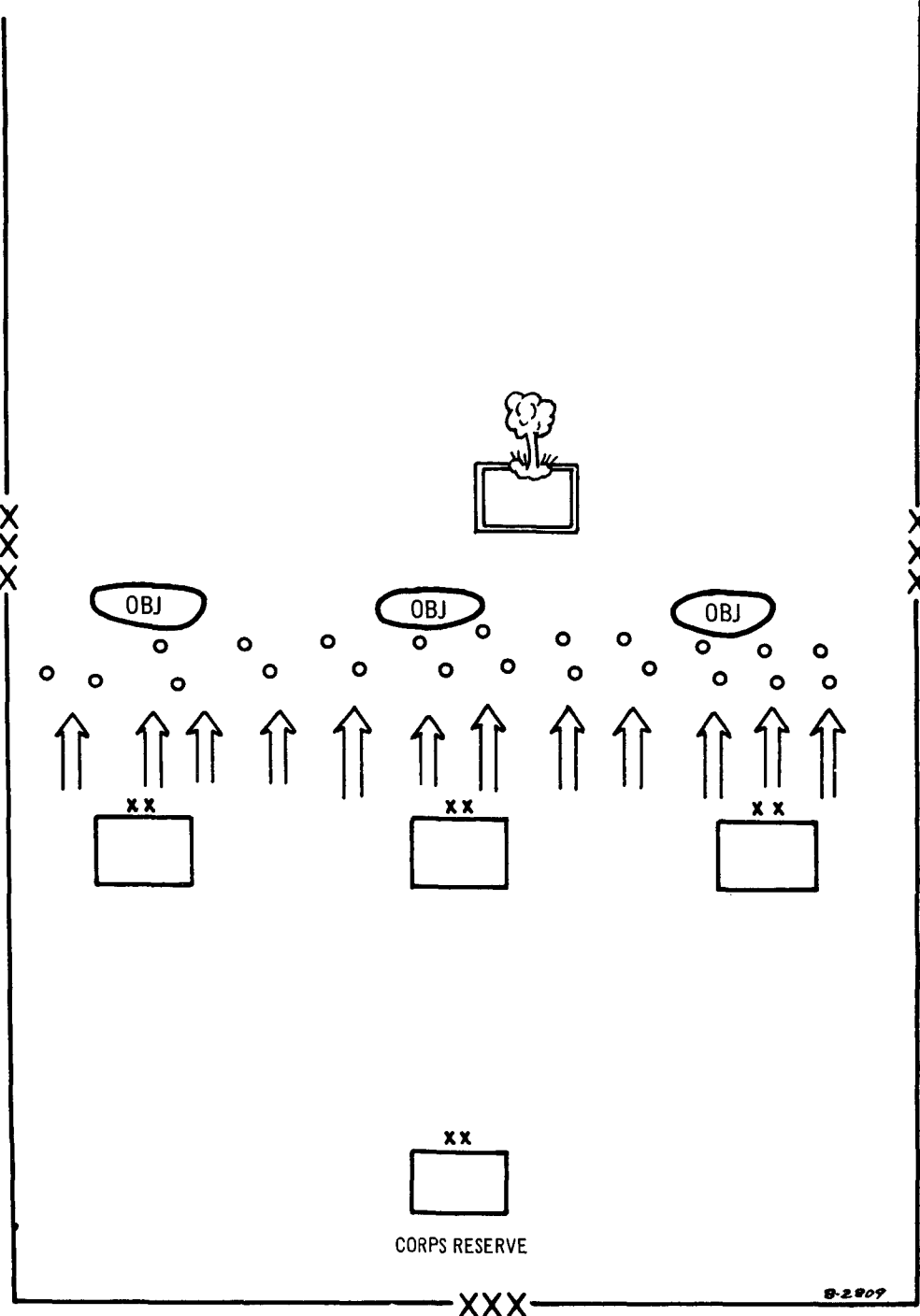

NOTE: Diagram is schematic only. Overlay techniques such as boundaries, phase lines, lines of departure, etc. are not shown.

Figure 8-3. Corps in the frontal attack.

pable of affecting the accomplishment of the mission, against enemy fire support means, and against command and control installations.

(4) Corps prepares the maneuver element of the corps reserve for commitment through the zone of the forces making the supporting attack to exploit unexpected successes in these areas.

(5) FM 61-100 covers division operations in making the penetration for the corps.

c. Corps Conducting a Frontal Attack.

(1) The frontal attack strikes the enemy all along his front. It is employed to overrun and destroy or capture a weaker enemy in position or to fix an enemy force in position to support another form of maneuver.

(2) The frontal attack is used against a weak or disorganized enemy; when the situation is not fully developed; when the attacker has overwhelming combat power; when the time and situation require immediate reaction to enemy action; or when the mission is to fix the enemy in position, deceive him, or assist the main attack (fig. 8-3).

(3) Although the frontal attack strikes along the enemy's entire front, it does not require all maneuver forces to employ in line or to conduct a frontal attack. Throughout this type of maneuver, the commander seeks to create or take advantage of conditions that will permit a penetration or envelopment of the enemy position.

(4) A reserve is retained to permit redistribution of forces and to take advantage of changes in the tactical situation.

(5) Corps frontal attacks, unless in overwhelming strength across the front, are seldom decisive; consequently, their adoption in the place of more decisive and less costly forms of maneuver is seldom justified.

d. Corps in an Envelopment. The fundamentals of the envelopment are the same at all levels. The main attack force or envelopment force passes around or over the enemy's main defensive position, secures objectives that cut his escape routes, and destroys the enemy from the flanks and rear (fig. 8-4).

(1) The corps main attack force moves rapidly to attack the enemy's assailable flank

while the supporting attack forces fix the enemy in his defensive position.

(2) Preparatory fires assist the supporting attacks in fixing the enemy in his position and enabling the enveloping force to pass around the enemy's flank and move directly to the corps objective. Corps delivers long-range nuclear fires against enemy forces capable of hindering the accomplishment of the mission.

(3) The maneuver element of the corps reserve may be used as the enveloping force, or it may exploit the success attained by the enveloping force or the supporting attack.

(4) FM 61-100 covers division operations as an enveloping force for the corps.

e. Corps in a Double Envelopment. The double envelopment is a variation of the single envelopment in which the corps employs two enveloping forces to pass simultaneously around both flanks of the enemy's main defense force while the supporting attack forces fix the enemy in his defensive position.

f. Corps Conducting a Turning Movement. The turning movement is a variation of the envelopment in which the main attack force passes around the enemy's main defense forces and secures objectives deep in the enemy's rear. The enemy is forced to abandon his prepared position and to turn his forces to meet a threat from a different direction and on terrain favorable to the attacker (fig. 8-5).

(1) The corps main attack force does not direct its efforts against the enemy position and avoids attacking the flanks or rear of this position. The objective of the main attack is to secure vital areas deep in the enemy rear and to prevent the escape, support, or reinforcement of the main force.

(2) Supporting attacks fix the enemy and prevent interference with the movement of the main attack force. Nuclear preparatory fires destroy or neutralize reserves capable of hindering the accomplishment of the mission of the main attack force. Long-range nuclear fires support the main attack force as it moves deep into the enemy rear.

(3) Since the main attack force and the supporting attack force may operate beyond mutually supporting distance, each must have sufficient combat power to avoid defeat in de-

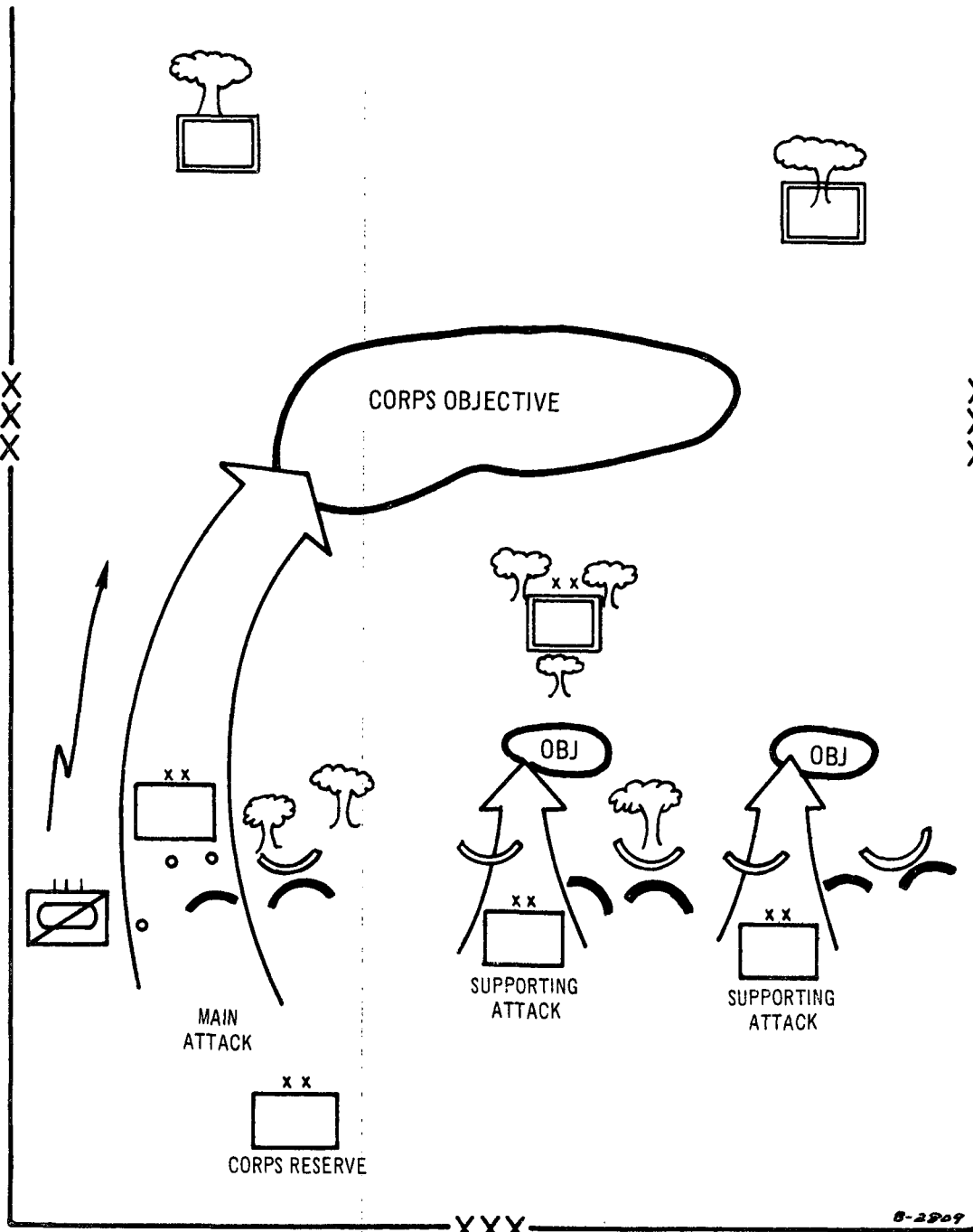

NOTE: Diagram is schematic only. Overlay techniques such as boundaries, phase lines, lines of departure, etc. are not shown.

Figure 8-4. Corps in the envelopment.

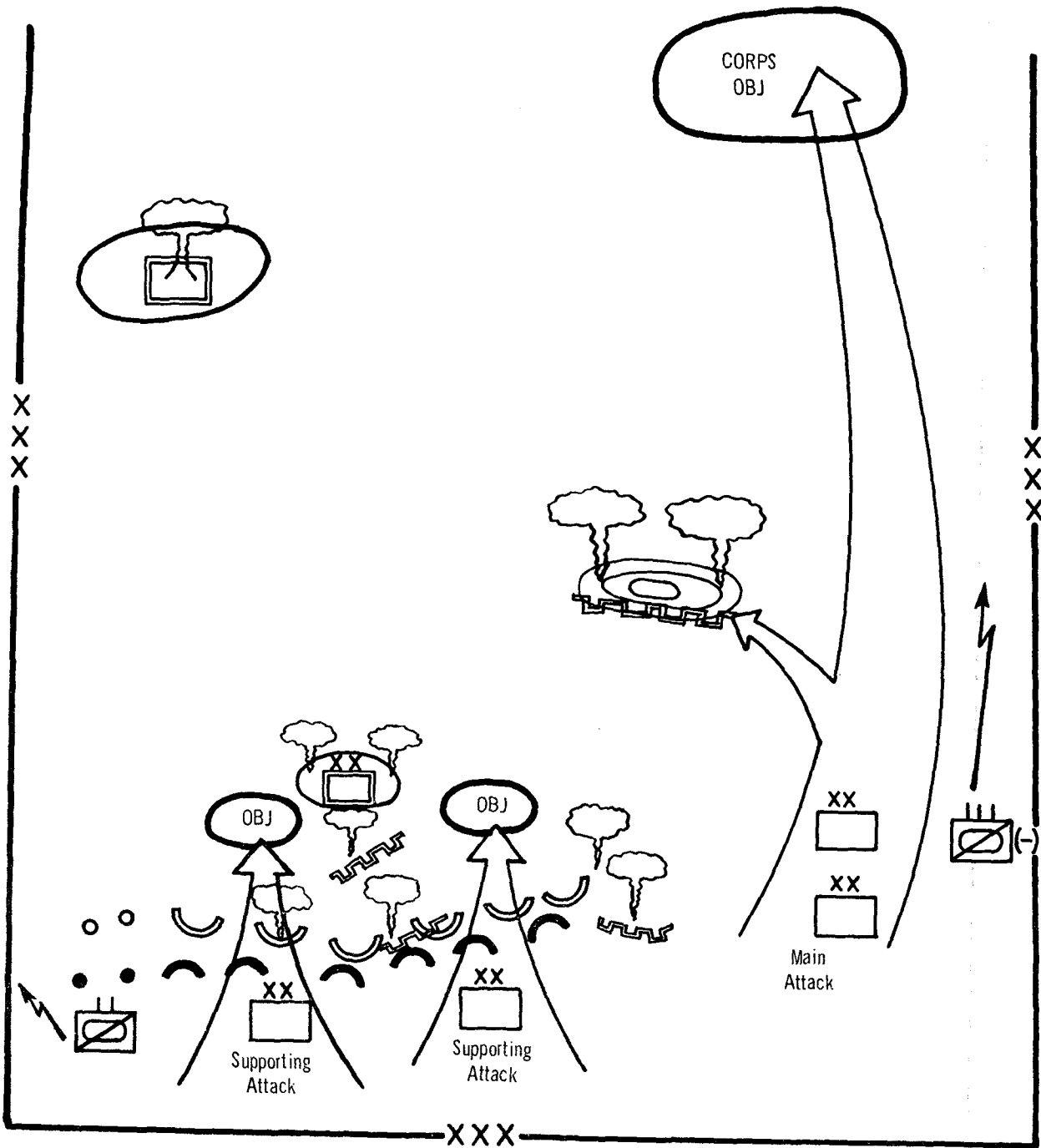

8-2809

NOTE: Diagram is schematic only. Overlay techniques such as boundaries, phase lines, lines of departure, etc. are not shown.

Figure 8-5. Corps conducting a turning movement.

tail. Nuclear weapons allocated to each attacking force provide a large component of the combat power needed.

(4) Although divisions can conduct a turning movement, more often corps and army use this variation of the envelopment.

(5) FM 61-100 covers operations of the division as the force conducting a turning movement.

g. Execution. The corps commander rarely specifies the form of maneuver to be adopted by the division. The corps operation order outlines the missions, zones of action, time of attack, and allocation of combat power to the divisions. The division commander normally is responsible for the details of the execution. The divisions' missions and the allocation of combat power to them may impose such limitations as to the time and direction of attack that there is little choice of the form of maneuver to be adopted.

8-29. Corps Reserve

a. The corps establishes a reserve that may consist of maneuver elements and nuclear or nonnuclear weapons. Throughout the battle, the corps maintains the momentum of the attack and adds impetus to it by properly employing the nuclear and nonnuclear fires retained under its control. The corps commander follows the progress of the battle and adjusts or modifies missions assigned to the subordinate units. He provides for the relief of divisions that have become exhausted in combat. At the proper time, he commits the maneuver elements of his reserve, supported by the shifting of necessary firepower to include nuclear weapons as applicable. Depending on the strength and disposition of hostile forces and the amount of information that he has concerning these matters, the corps commander varies the size of the reserve of maneuver elements and nuclear weapons retained.

b. The maneuver elements of the corps reserve may include a division, a separate brigade, and the armored cavalry regiment. On occasions, the corps reserve may be the reserve of one or more of the divisions, with specific restrictions imposed by corps on its employment by the divisions. The positioning of the reserve facilitates its anticipated employment. In offensive operations, the corps reserve is committed directly under corps control. Corps may attach the armored cavalry regiment and the separate brigades to one of the divisions for employment.

c. During nuclear operations, the corps commander considers nuclear weapons a major element of the corps reserve. Paragraph 8-25 relates to corps role in nuclear weapon employment.

8-30. Follow and Support Forces

a. Corps normally employs a follow and support force in support of a corps exploitation conducted by an armored or mechanized division. The mission of the follow and support force is to hold and widen the shoulders of a penetration, to secure lines of communications behind the lead exploiting force, to relieve elements of the leading force left behind to secure key terrain, to assist in destruction of bypassed pockets of resistance, and to block movement of enemy reinforcements.

b. A corps conducting the exploitation and pursuit for the field army normally has additional reinforcements to insure success (para 7-37). Elements assigned the follow and support missions are fully committed and are not considered a part of the reserve. The exploitation force and the follow and support force commanders maintain direct communication and coordination. The corps commander, however, maintains command over both forces. The corps commander insures the forward echelonment of field army combat service support elements to support operations.

Section V. DEFENSIVE OPERATIONS

8-31. General

a. The fundamental considerations of mutual support, proper use of terrain, security,

all-round defense, defense in depth, responsiveness, dispersion, maximum use of offensive action, integration and coordination of defensive

measures, and the time available for planning and preparation apply to the corps.

b. Paragraphs 8-9 through 8-20 discussed the means available to the corps commander for the conduct of defensive operations, together with the general principles or procedures for employing these means in all types of operations. This section discusses relevant aspects of planning and conducting corps defensive operations and must be considered in conjunction with the general operational considerations outlined in paragraphs 8-9 through 8-21.

8-32. Forms of Defense

The fundamental forms of defense, mobile and area, are at opposite ends of the spectrum with many variations possible between the extremes. Within a corps conducting a defense, the operations of its subordinate elements may encompass variations of both the mobile defense and the area defense. In nuclear operations, terrain conditions permitting, the mobile defense, possibly modified, is preferred at corps. The distinction in the form of defense that corps employs rests primarily in the corps commander's intent since the subordinate units may engage in both forms of defense. The form of defense employed depends on the corps' mission; the nature of the terrain; the opposing forces' relative combat power, including mobility; the nuclear environment; and the air situation. FM 61-100, chapter 6, discusses special defensive considerations against armored and mechanized forces.

a. Mobile Defense.

(1) Assignment of a mission by field army that permits the defense to be organized and fought in depth favors adoption of the mobile defense. Defensive operations in terrain that permit maneuver of defensive forces favor the mobile defense. A favorable degree of mobility of the defending forces is a prerequisite for adoption of the mobile defense. The mobility of a force is always relative to the mobility of the enemy and is a compound of equipment, training, communications, and terrain. The organic mobility of the mechanized and armored divisions and the capability of the corps to mechanize, airlift, or motorize infantry divisions are considerations for adopting the mo-

bile defense. During nuclear operations, the dispersion and mobility required to decrease the vulnerability of the defending forces favor the mobile defense. The capability of employing nuclear weapons permits the defense of a larger area than would otherwise be possible. Friendly local air superiority facilitates the maneuver required in the mobile defense.

(2) In the mobile defense, the corps deploys forces forward to warn of impending attacks, to canalize the attacker into less favorable terrain, and to block and impede the attacker. At least one division in the forward defensive area has the mission of delay. This delay is envisioned as a bowing back of the forward edge of the battle area (FEBA), as enemy pressure is exerted at a given point, up to a predetermined position where the corps counterattack force can be committed. The corps employs the bulk of its maneuver elements in vigorous offensive action to destroy the enemy at a decisive time and place. The primary mission of the counterattack in the mobile defense is the destruction of the hostile force (fig: 8-6).

(3) Corps can achieve depth in its sector by locating combat and combat support units in depth, by requiring the divisions to prepare positions in depth, and by designating and constructing corps blocking positions. Corps blocking positions that may be located in the division rear areas are occupied only on corps order.

b. Area Defense.

(1) Assignment of a mission by field army that requires the retention of specific terrain may dictate a corps area defense. Operations in terrain that restricts the movement of the corps maneuver elements may dictate an area defense. The enemy's possession of superior tactical mobility indicates adoption of the area defense. Enemy local air superiority limits extensive maneuver by corps forces and thus favors an area defense.

(2) In the area defense, the corps places the bulk of its combat forces in the forward defense area. The corps reserve executes counterattack plans, reinforces forward units, or executes blocking missions. The primary mission of the counterattack in the area defense is

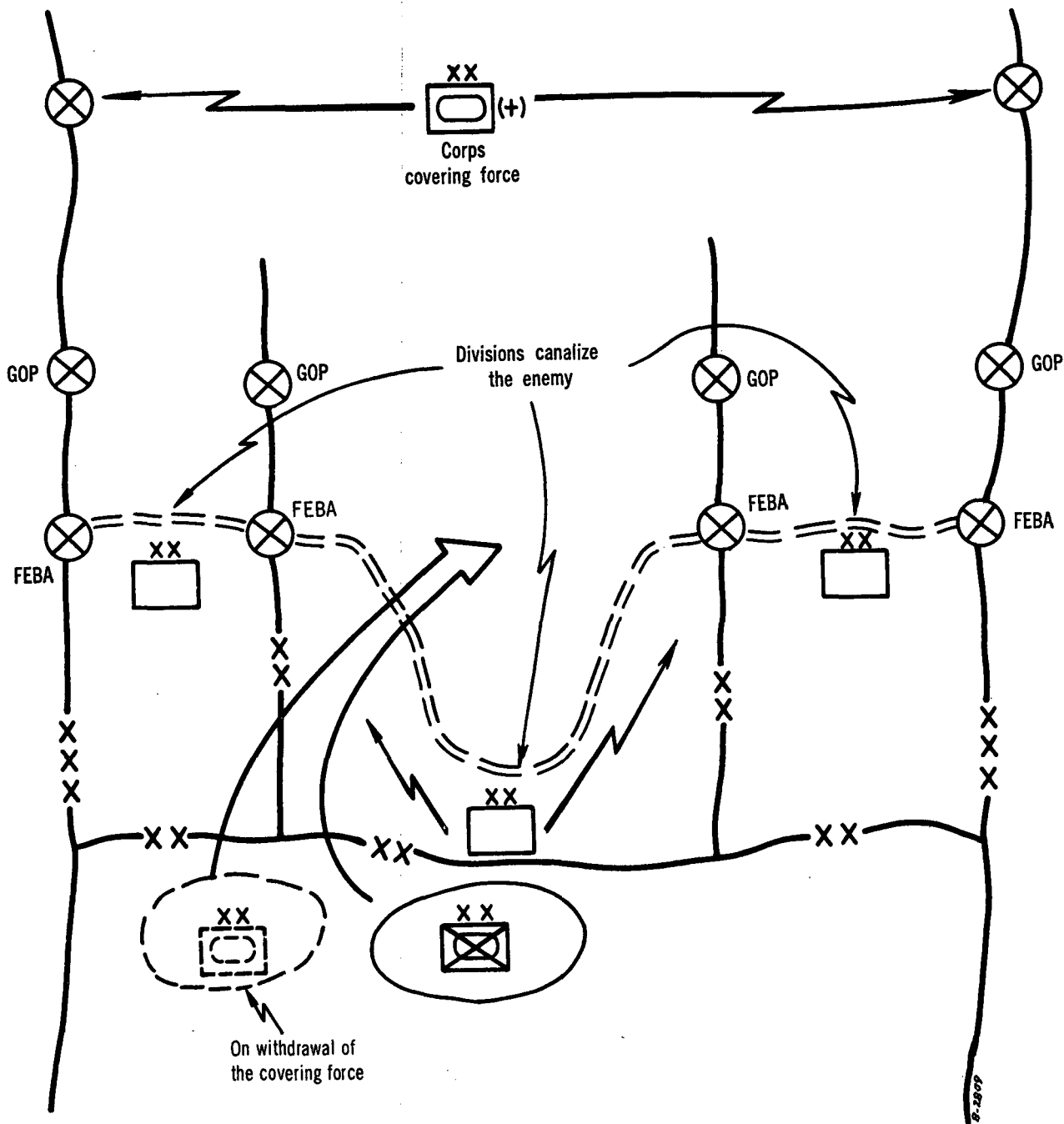

Figure 8-6. Example of a corps conducting a mobile defense.

to destroy or eject the enemy force in the penetration and to regain control over the forward defense area (fig. 8-7). The corps reserve is positioned farther forward in an area defense than in the mobile defense. The reserve nor-

mally will be disposed laterally, rather than in a centralized location, in recognition of the more restrictive nature of an area defense. This recognizes the difficulty of maneuvering large reserves in an area defense.

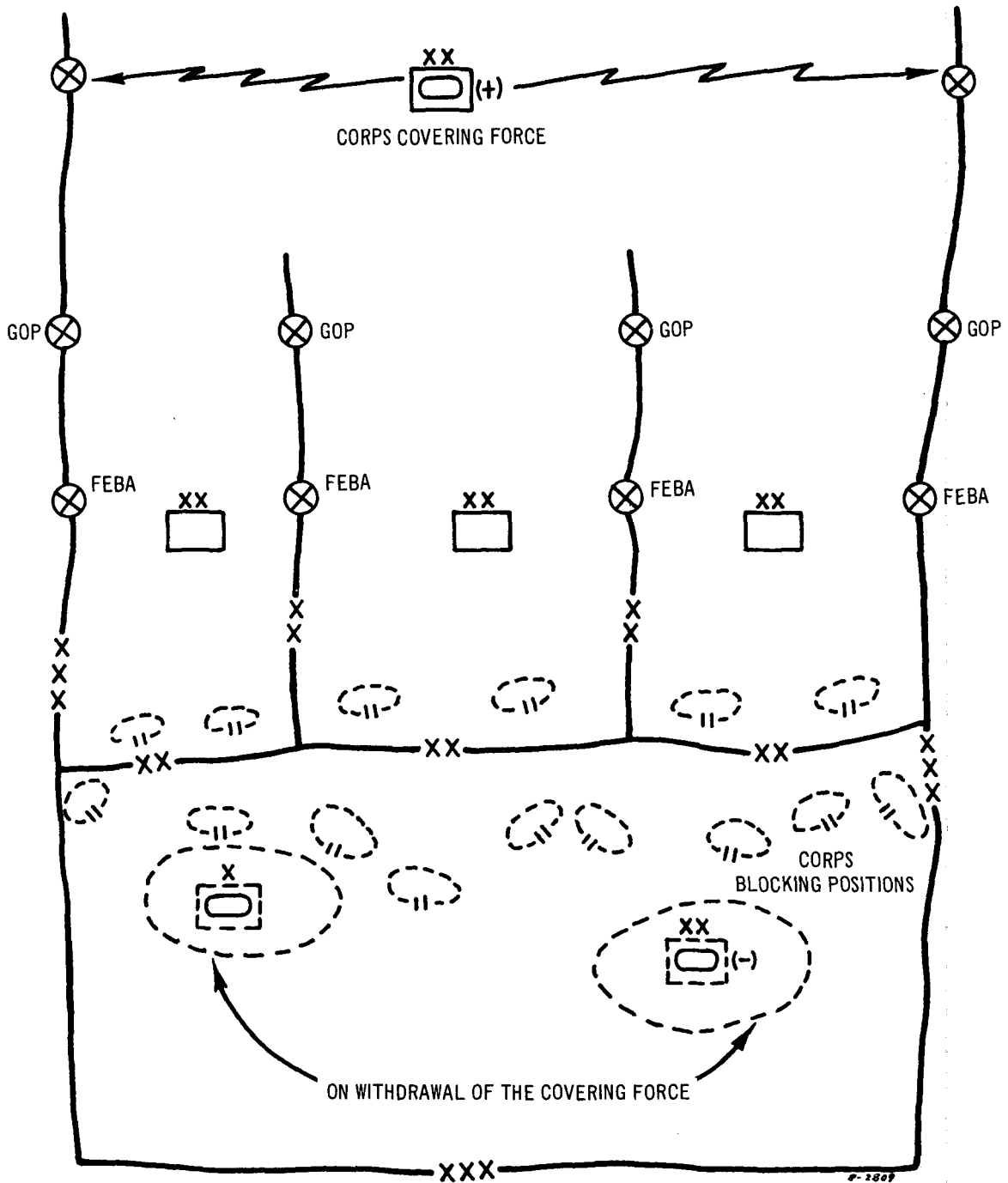

Figure 8-7. Example of a corps organization for area defense.

8-33. Defensive Echelons

Defensive echelons include the security echelon, the forward echelon, and the reserve eche-

lon. Each echelon is allocated forces and fires of the corps in accordance with the corps defensive plan.

8-34. Security Echelon

a. The area of the security echelon begins at the FEBA and extends to whatever distance to the front and flanks that have security elements. Security elements may include a covering force, flank and rear security, and air surveillance units.

b. When employing a corps covering force, the corps commanders recommend the location of the initial coordinating points to the field army commander who designates such points. Corps prescribes the composition of the covering force, basing the composition on the mission, forces available, the terrain, and the enemy's combat capabilities. An armored or a mechanized division usually forms the nucleus of the covering force. Corps may use the armored cavalry regiment, suitably reinforced, when long delays are not required. Appropriate reinforcements include long-range fire support, air defense, engineers, and transportation means.

c. The mission of a corps covering force emphasizes maximum delay and disruption of the enemy advance. All action is directed toward providing time to the units organizing the forward defense. By delaying the enemy and deceiving him as to the true location of the FEBA, by forcing him to deploy his forces prematurely, by inflicting maximum casualties as he advances, and by providing early warning of his movements, the covering force gains additional time for the organization of the forward defense. Nuclear weapons allocated to the covering force provide a powerful means for accomplishing the mission. Nuclear weapons not expended by the covering force are available for reallocation after its withdrawal. Use of atomic demolitions by the covering force is carefully coordinated with future plans of the corps and field army.

d. Field army normally designates the period that the corps covering force is to hold the enemy forward of the FEBA.

e. The corps may direct the establishment of a general outpost and designate the coordinating points within the corps sector. Composition of the general outpost is the responsibility of the division commanders. The corps commander normally prescribes the time that the

general outpost is to hold the enemy forward of the FEBA, but may delegate the authority to the divisions.

8-35. Forward Defense Echelon

a. As a part of a field army, the corps conducts defensive operations in conformance with the field army commander's instructions. The corps commander describes the general location of the corps defensive area by designating coordinating points on the FEBA for the major subordinate units.

b. The designation of the coordinating points between the divisions (and other subordinate elements employed) on the FEBA and the designation of lateral and rear boundaries fix the sectors assigned to the subordinate units. The missions assigned to the units and evaluation of the terrain, the enemy capabilities, and the capabilities of the friendly units of the forward defense echelon primarily determine the assignment of sectors to subordinate units. The corps uses the capabilities of infantry, mechanized, or tank battalions as a guide for assignment of division sectors.

c. Corps establishes the lateral limits of each division sector by designating lateral boundaries. Corps assigns the responsibility for each major avenue of approach into the corps sector to a single division. At corps, a major avenue of approach permits the unrestricted maneuver of the major combat elements of at least one division-size unit.

d. Limitations on available forces for employment on the FEBA or the assignment of extended frontages may require the corps to conduct a detailed examination of the terrain and enemy capabilities to determine where the corps locates its most effective maneuver elements and where it can best economize. The armored cavalry regiment or separate brigade, or both, may be economy of force units for such a situation.

e. Blocking positions both in the area defense and in the mobile defense add depth to the defensive positions. Especially in the mobile defense, corps frequently keys their locations to priority counterattack plans. Corps engineers, reserve units, other corps troops, and (as a last priority) frontline divisions con-

struct corps blocking positions, which are full-scale defensive positions, prepared as thoroughly as time and materials permit.

8-36. Reserve Echelon

a. The corps reserve normally is in that portion of the corps rear behind the forward defense echelon; i.e., the area behind the division rear boundaries. Maneuver elements of the corps reserve may also be positioned within a division rear area. Additionally, the maneuver element of the corps reserve may be a unit of one of the divisions.

b. The corps commander normally establishes a reserve of maneuver elements and fires. Nuclear weapons may be the decisive element of his reserve. The discussion in paragraph 8-29 relative to the composition of the reserve in offensive operations applies to corps defensive operations.

8-37. Allocation of Combat Power

The corps allocates combat and combat support units, including nuclear fires, to the divisions as needed to accomplish their missions. In determining the allocation of means to the divisions, corps visualizes how each division can defend the assigned sectors with the means available. The corps commander's visualization of the employment of combat means is essential to the soundness of the planned allocation of combat power. The actual disposition of divisions and their attachments and the planned employment of other support allocated to the division are the division commander's responsibilities. The division assigned the responsibility for defending the most dangerous avenues of approach receives priority on the allocation of combat power. Just as the commander weights the main attack with responsive support, so does he weight the defense of the most critical sector.

8-38. Missions to Subordinate Units

The corps normally does not prescribe the form of defense for use by the division or other subordinate units on the FEBA. Divisions are assigned their defensive sectors, and the details of execution normally are left to the division commanders. The size of the sector assigned to the division, the terrain, and the

combat power allocated to or placed in support of the division, the air situation, the time available for organizing the defense, and the capabilities of the enemy forces largely determine the form of defense to adopt. In the mobile defense, a division with a delay mission employs the principles of delay outlined in FM 61-100 in consonance with the corps scheme of defense.

8-39. Corps Counterattack Planning

a. A corps counterattack is a coordinated corps operation with the corps reserve making the main attack. The counterattack plan developed by the corps staff is a corps operation plan. All subordinate units assigned missions in the corps plan develop implementing plans and submit them to corps.

b. Corps counterattack planning is based on several assumptions. The corps staff translates most of these assumptions into one or more penetrations of the corps forward defense area. A penetration is located along a major avenue of approach; is directed toward key terrain or other objectives; and is given a width and depth based on the terrain, corps defense plans, and the enemy tactical doctrine. The size of the enemy force assumed to be within the penetration primarily determines the width of the penetration. The depth of the penetration is the maximum distance permitted the enemy by the time that the corps reserve crosses the line of departure.

c. Corps counterattack plans include—

- (1) Assumed penetrations. See *b* above.
- (2) Line of departure. Corps prescribes a line of departure (LD) for planning purposes. When combined with an objective, it also serves as a directional measure. The LD used for the actual counterattack rarely is the same as the LD used in planning.
- (3) Objective. The plan assigns the reserve a mission, an objective, or a limit of advance as appropriate.
- (4) Boundaries. Boundaries are designated between the reserve and the division or divisions whose areas are penetrated.
- (5) Direction of attack. The plan may prescribe a direction of attack if required; however, this normally is too restrictive a control measure for use at corps.

(6) Command and control. The plan normally prescribes instructions to insure unity of command and effort during the passage of lines and in the sector or zone of the counterattack.

(7) Reserve. The plan normally prescribes instructions concerning reconstitution of a corps reserve when corps uses the original reserve in the counterattack.

d. Nuclear weapons for employment in the counterattack initially are a part of the corps reserve. The commander of the corps reserve maneuver force receives an allocation for each counterattack plan that he develops. The allocation indicates the number of weapons by type, yield, and delivery system available for the counterattack force to employ. The allocation permits the detailed integration of nuclear fires and maneuver.

8-40. Conduct of the Counterattack

a. The commander counterattacks when the enemy attack slows, stops, or becomes disorganized, preferably before the enemy can consolidate his gains and reorganize or regroup his forces.

b. The corps commander's problem concerning the proper time to launch the counterattack is considerably more complicated than the division commander's, chiefly because of the time and space factors in committing the reserve. The commander measures the time required to execute the corps counterattack plan in hours, and the commander and his staff continuously evaluate the tactical situation to insure a timely commitment of the reserve.

c. The reserve commander commands the corps reserve in accordance with corps-approved plans modified as required by the situation.

Section VI. RETROGRADE AND SUPPORTING OPERATIONS

8-41. Retrograde Operations

a. The corps plans and conducts retrograde operations as field army directs.

b. Retrograde operations are withdrawal, delaying action, and retirement.

c. A corps retrograde operation usually is a combination of the withdrawal, delaying action, and retirement.

d. Paragraphs 7-48 and 7-51 discuss the field army role in planning retrograde operation.

8-42. Corps Planning

a. Field army designates the location of the new defensive position. Corps planning for the retrograde operation begins with the preparation of the corps defense plan for the new position. Field army fixes the corps defensive sector through the designation of coordinating points on the FEBA between the corps and the location of the corps boundaries. The corps commander, in turn, prescribes the general trace of the FEBA and designates the coordinating points between units on the FEBA. The principles outlined in paragraphs 8-9 through 8-21 and 8-31 through 8-40 apply in planning the corps defense.

b. After developing the corps defense plan for the new position, the corps plans for its retrograde movement into the new position. The corps begins its rearward movement and closes into the new defensive area at times that field army specifies. Field army also specifies sectors of responsibility for each of the corps in the retrograde operation.

c. The corps retrograde plan includes provision for—

- (1) Location, composition, and mission of the corps covering force.
- (2) Organization of the corps for combat.
- (3) Employment of nuclear weapons.
- (4) Control measures including traffic control.

8-43. Corps Covering Force

a. The corps commander normally plans the employment of a covering force. The covering force delays the enemy forward of the general outpost at the new defensive position for a specific time, disorganizes the attacking enemy forces as much as possible, and deceives the enemy as to the location of the FEBA. Accomplishment of this mission provides time for preparation of the defensive position.

b. Paragraph 8-34 discusses the composition of a corps covering force. In addition to that discussion, the following points also apply. The retrograde operation preserves the integrity of the command; therefore, the enemy combat power that forces the retrograde movement dictates a stronger covering force than that employed in the typical corps defense discussed in paragraphs 8-31 through 8-40. The capability of the armored and mechanized divisions of covering a wide area and conducting continuous delay makes them the most suitable units for the corps covering force in the retrograde operation. Augmentation of the division to include attachment of an armored cavalry regiment, field artillery, including long-range fire support means, air defense artillery, and engineers, is normal. The allocation of nuclear weapons to the covering force greatly improves its capability of achieving the desired delay.

c. The corps commander prescribes the composition and location of the corps covering force, assigns the mission, and allocates nuclear weapons to the covering force commander. The detailed plans for the execution of his delay mission are the responsibility of the covering force commander.

d. The covering force accomplishes its mission by delay in successive positions, by delay on alternate positions, or by combination of the two. FM 61-100 contains the conduct of delaying actions by divisions.

8-44. Organization of the Corps for Combat

a. The corps commander simultaneously determines the composition of the corps covering force and organizes the corps for combat for the retrograde operation. Since the main body of the corps disengages and moves through the covering force, continues its rearward movement to the new position, and prepares the new defensive area, the corps commander has the problem of organizing the corps to achieve a proper balance between the force preparing the new position and the force covering the retrograde movement. After disengaging, the corps commander relies on organic and supporting reconnaissance and surveillance means to maintain contact with the enemy forces with retrograde operations.

b. The attachment of combat and combat support units to division is normal when division needs this support to accomplish its assigned mission. Corps normally maintains a very small troop reserve because of the decentralization of the execution of retrograde operations.

c. During the initial phase of a retrograde operation, units in the forward defense area disengage from the enemy force except for delaying or security elements. Fire support may be required to assist divisions in disengaging. When operating on an extended front, the commander frequently attaches corps artillery units to the divisions to provide the necessary fire support. As the withdrawing units pass through the covering force, designated corps artillery units are detached from the division and attached to the covering force. Corps artillery regains control of the corps artillery units attached to the divisions or the covering force as early as practicable, consistent with the corps organization for combat at the new defensive position.

d. Within its means corps provides additional transportation to forward infantry divisions to facilitate their withdrawal.

e. Corps attaches air defense units to the covering force. Air defense units normally are retained under corps control; however, the situation, frontage, terrain, or other factors may require attachment of air defense units to provide support.

f. Corps engineer units have two basic missions in retrograde operations: to assist the movement of the friendly force and to impede the advance of the enemy through construction of obstacles and the planned destruction of installations, supplies, and structures. These units prepare and execute demolitions and create minefields on order in accordance with the corps plans. Corps engineer units normally assist in preparing defensive positions and barriers. Corps establishes priorities for engineer work.

8-45. Employment of Nuclear Weapons

a. The development of nuclear weapons and the doctrine relative to their employment on the nuclear battlefield have not materially

changed the concept for a retrograde operation. The basic problem confronting the corps commander is to disengage his force and still preserve its tactical integrity and then to move to the next defensive position without offering the enemy the opportunity to pursue and destroy his corps.

b. In a retrograde operation under conditions of nuclear versus nonnuclear warfare these two general areas of basic difference exist: closeness of engagement and time of the withdrawal. Before tactical nuclear weapons, the commander could ill afford his forces' becoming too closely engaged with the enemy, for it could preclude their breaking contact. Conventional artillery and air support or skillfully executed counterattack could break contact with the enemy and permit the retirement or delay to begin. Tactical nuclear weapons have influenced withdrawal tactics to the extent that, with this additional firepower available, the commander now can accept closer engagements with the enemy than before without relying on a large ground reserve to assist his forward units in breaking contact. Tactical nuclear weapons speed up the disengagement and permit the employment of a larger portion of the command in close combat.

c. Tactical nuclear weapons also influence the time of withdrawal of the forward units. Although commanders prefer a voluntary withdrawal from contact to an involuntary withdrawal, the accurate and timely employment of nuclear weapons may enable a defender to execute a withdrawal under conditions that enemy observation normally would preclude.

8-46. Control of the Retrograde Movement

a. The corps plan includes the control meas-

ures necessary to insure a coordinated operation. The corps establishes lateral boundaries between the divisions and extends them rearward through the new defensive position. The corps commander's concept phases the operation and indicates the delay desired between positions. Phase lines are also used for control as appropriate.

b. Traffic control in division forward areas is the division's responsibility. Once the division has begun its movement to the rear, division military police become part of the division column. When forward units disengage, they move through the corps covering force. Traffic control becomes the corps' primary problem in moving to the new defensive position. Military police elements supporting corps perform the traffic control mission throughout the entire corps sector. The corps commander assigns responsibility for traffic control to military police units on an area basis or on a route basis, depending on the terrain, the number of withdrawal routes available, and the availability of military police units. Corps establishes holding areas at critical points on withdrawal routes such as blown bridges or defiles so that convoys may be rerouted into these areas to prevent presenting the enemy a nuclear target. With reduced congestion on the withdrawal route, convoys can move back to the withdrawal route and resume their retrograde movement.

8-47. Supporting Operations

The corps plans and conducts tactical cover and deception operations, barrier operations, and denial operations in accordance with missions that the field army assigns. Paragraphs 7-52 through 7-55 contain a discussion of supporting operations.

APPENDIX A

REFERENCES

A-1. Joint Chiefs of Staff Publications (JCS)

- 1 Dictionary of United States Military Terms for Joint Usage.
- 2 Unified Action Armed Forces (UNAAF).
- (C) 3 Joint Logistics and Personnel Policy and Guidance (U).
- (FOUO) 4 Organization and Function of Joint Chiefs of Staff (U).
- (FOUO) 8 Doctrine for Air Defense From Oversea Land Areas (U).

A-2. Army Regulations (AR)

- 1-70 Standardization Among Armies of the United States—United Kingdom—Canada.
- 1-71 Standardization Among the Countries of the North Atlantic Treaty Organization.
- 10-1 Functions of the Department of Defense and Its Major Components.
- (C) 10-122 United States Army Security Agency (U).
- (C) 105-87 Electronic Warfare (Electronic Countermeasures and Electronic Countermeasures) (U).
- 320-5 Dictionary of United States Army Terms.
- (C) 380-8 Army Communications Security Policies, Objectives, and Responsibilities (U).
- 320-50 Authorized Abbreviations and Brevity Codes.

A-3. Department of the Army Pamphlets (DA Pam)

- 310-series Military Publications.

A-4. Field Manuals (FM)

- 1-20 Nondivisional Combat Aviation Battalion, Group, and Brigade.
- 1-100 Army Aviation Utilization.
- 1-110 Armed Helicopter Employment.
- 3-1 Chemical, Biological, Radiological (CBR) Combat Service Support TASTA-70.
- 3-10 Employment of Chemical and Biological Agents.
- (S) 3-10A Employment of Biological Agents (U).
- (C) 3-10B Employment of Chemical Agents (U).
- 3-12 Operational Aspects of Radiological Defense.
- 3-50 Chemical Smoke Generator Units and Smoke Operations.
- 5-1 Engineer Troop Organizations and Operations.
- 5-15 Field Fortifications.
- 5-26 Employment of Atomic Demolition Munitions (ADM).
- 5-142 Nondivisional Engineer Combat Units.
- 5-162 Engineer Construction and Construction-Support Units.
- 6-20-1 Field Artillery Tactics.
- 6-20-2 Field Artillery Techniques.
- 7-30 Infantry, Airborne, and Mechanized Division Brigades.

8-10	Medical Service, Theater of Operations.
9-6	Ammunition Service in Theaters of Operations.
11-20	Signal Operations, Theater of Operations.
11-21	Tactical Signal Communication Systems, Army, Corps, and Division.
11-23	U.S. Army Strategic Communications Command (Theater).
11-75	Army Command Radio and Cable Battalion.
11-86	Combat Area Signal Battalion Army.
11-92	Corps Signal Battalion and Airborne Corps Signal Battalion.
11-95	Army Command Signal Operations Battalion.
17-30	The Armored Division Brigade.
17-95	The Armored Cavalry Regiment.
19-15	Civil Disturbances and Disasters.
19-40	Enemy Prisoners of War and Civilian Internees.
19-45-1 (Test)	Rear Area Protection.
21-40	Chemical, Biological, and Nuclear Defense.
24-1	Tactical Communications Doctrine.
30-5	Combat Intelligence.
30-9	Military Intelligence Battalion, Field Army.
(C) 30-17	Counterintelligence Operations (U).
(C) 30-31	Stability Operations—Intelligence (U).
(S) 30-31A	Stability Operations—Intelligence (U).
31-10	Denial Operations and Barriers.
31-11	Doctrine for Amphibious Operations.
31-12	Army Forces in Amphibious Operations (The Army Landing Force).
31-16	Counter guerrilla Operations.
31-18	Long Range Reconnaissance Patrol Company.
31-20	Special Forces Operational Techniques.
31-21	Special Forces Operations.
(S) 31-21A	Special Forces Operations (U).
31-22	U.S. Army Counterinsurgency Forces.
31-23	Stability Operations, U.S. Army Doctrine.
(C) 31-40	Tactical Cover and Deception (U).
31-73	Advisor Handbook for Stability Operations.
(C) 32-5	Signal Security (SIGSEC) (U).
(S) 32-10	United States Army Security Agency in Support of a Field Army (U).
(C) 32-20	Electronic Warfare (Ground Based) (U).
(S) 32-20A	Electronic Warfare (Ground Based) (U).
33-1	Psychological Operations—U.S. Army Doctrine.
33-5	Psychological Operations—Techniques and Procedures.
41-5	Joint Manual for Civil Affairs.
41-10	Civil Affairs Operations.
44-1	U.S. Army Air Defense Artillery Employment.
54-2	The Division Support Command.
54-3	The Field Army Support Command.
54-6	The Area Support Command.
54-7	The Theater Army Support Command.
55-6	Transportation Service in Theaters of Operations.
57-1	U.S. Army/U.S. Air Force Doctrine for Airborne Operations.
57-35	Airmobile Operations.

61-100	The Division.
100-5	Operations of Army Forces in the Field.
100-10	Combat Service Support.
(C) 100-20	Field Service Regulations: Internal Defense and Development (IDAID) (U).
100-27	U.S. Army/U.S. Air Force Doctrine for Tactical Airlift Operations.
101-5	Staff Officers' Field Manual—Staff Organization and Procedure.
101-10-2	Staff Officers' Field Manual—Organizational, Technical, and Logistical Data—Extracts of Organization and Equipment.
101-31-1	Staff Officers' Field Manual—Nuclear Weapons Employment, Doctrine and Procedures.
101-40	Armed Forces Doctrine for Chemical and Biological Weapons Employ- ment and Defense.

INDEX

	Paragraph	Page
Advance to contact	8-26	8-9
Air and naval gunfire liaison company	7-18	7-14
Air defense (<i>See</i> theater army air defense brigade.)	4-2, 4-14, 4-15, 7-12	4-1, 4-7, 7-5
Air defense artillery:		
Corps	8-11	8-4
Field army	7-12	7-5
Air interdiction	6-9, 8-15	6-3, 8-6
Air reconnaissance	6-9, 8-15	6-3, 8-6
Air support of ground operations:		
Air interdiction	6-9, 7-16, 8-15	6-3, 7-8, 8-6
Air reconnaissance	6-9, 7-16, 8-15	6-3, 7-8, 8-6
Airlift	6-9, 7-16, 8-15	6-3, 7-8, 8-6
Armed helicopter	7-17, 8-16	7-11, 8-7
Close air support	6-9, 7-16-7-18, 8-15	6-3, 7-8, 8-6
Coordination of air-ground operations at army group	6-10	6-4
Coordination of air-ground operations at corps group	8-15	8-6
Coordination of air-ground operations at field army	7-16	7-8
Immediate tactical air support missions	7-16, 8-15	7-8, 8-6
Military intelligence battalion, air reconnais- sance support	7-16	7-8
Navy and Marine Corps participation	6-9-6-11, 7-18, 8-17	6-3, 7-14, 8-7
Preplanned tactical air support missions	7-16, 8-15	7-8, 8-6
Tactical air reconnaissance	6-9, 7-16, 8-15	6-3, 7-8, 8-6
Airlift	6-9, 7-16, 8-15	6-3, 7-8, 8-6
Airmobile operations	8-20	8-7
Amphibious operations	6-11, 7-18	6-5, 7-14
Area communication system	7-20	7-16
Area defense	7-40, 8-32	7-24, 8-16
Area of operations (<i>See</i> theater of operations.)		
Armed helicopter	7-17, 8-16	7-11, 8-7
Armored cavalry regiment	7-11, 8-10	7-5, 8-4
Army aviation	7-17, 7-20, 8-11, 8-16, 8-20	7-11, 7-16, 8-4, 8-7
Army group:		
Combat service support functions	6-7	6-2
Command	6-3	6-1
Coordination of air-ground operations	6-10	6-4
Headquarters	6-4	6-1
Letter of instructions	6-8	6-2
Navy and Marine Corps participation	6-9-6-11	6-3
Nuclear weapons	6-12	6-5
Organization	4-34, 6-2	4-12, 6-1
Planning and conduct of operations	6-8	6-2
Reserve	6-12	6-5
Staff	6-5	6-2
Strategic and tactical functions	6-6	6-2
Tactical air support	6-9-6-11	6-3

	Paragraph	Page
Army mission, performance	2-2	2-1
Army role	2-1	2-1
Army Security Agency (<i>See</i> USASA.)		
Artillery (<i>See</i> also fire support.)	7-12, 8-11	7-5, 8-4
Barriers	7-54	7-29
Brigade, separate	7-11, 8-10	7-5, 8-4
Chain of command	3-8	3-2
Chemical and biological weapons (<i>See</i> fire support.)	7-15, 8-14	7-7, 8-6
Chief of Staff, U.S. Army	3-5	3-1
Close air support	6-9, 7-16—7-18, 8-15	6-3, 7-8, 8-6
Cold war	1-1, 2-1	1-1, 2-1
Combat service support	2-3, 3-12, 3-13, 3-21, 3-22, 4-2, 4-3, 4-5, 4-8, 4-9, 4-13, 4-16— 4-18, 5-1, 5-4, 5-7, 6-7, 7-21, 7-22, 7-57, 7-58, 8-3, 8-5	2-1, 3-6, 3-7, 3-10, 3-11, 4-1, 4-3, 4-4, 4-6, 4-7, 5-1, 5-2, 6-2, 7-17, 7-30, 7-31, 8-1
Combat support	7-20, 8-20	7-16, 8-7
Combat zone	3-11	3-4
Combined operations	3-10	3-4
Commander:		
Army combat forces	5-1—5-7, 6-1—6-3, 6-7	5-1, 6-1, 6-2
Army group	6-3	6-1
Field army	4-20, 7-5—7-9	4-8, 7-3
Theater (unified command commander)	3-7, 3-12	3-2, 3-6
Theater army	3-7, 4-3—4-5, 4-8—4-15, 4-18, 4-20, 4-25, 4-26, 4-31, 4-35, 5-1—5-7	3-2, 4-1, 4-4, 4-8, 4-10, 4-11, 4-12, 5-1
Theater army air defense brigade	4-14, 4-15	4-7
Theater army support command	4-16—4-19	4-7
Unified command (<i>See</i> theater commander.)		
Commander in Chief, U.S. Armed Forces	3-1	3-1
Communications systems	4-20—4-22, 7-20, 8-20	4-8, 7-16, 8-7
Communications zone	3-11	3-4
Component forces, Service	3-13	3-7
Corps:		
Artillery employment	8-11	8-4
Combat service support	7-57, 7-58, 8-3, 8-5	7-30, 7-31, 8-1
Command and staff actions	8-6	8-3
Headquarters	8-3	8-1
Independent and separate	7-56—7-58, 8-1, 8-3, 8-5	7-30, 8-1
Maneuver units	8-10	8-4
Nuclear weapons	8-11—8-13, 8-25, 8-29, 8-34, 8-36, 8-37, 8-39, 8-42, 8-43, 8-45	8-4, 8-9, 8-15, 8-19, 8-20, 8-21, 8-22
Operation order	8-8	8-3
Organization	8-2	8-1
Phasing	8-7	8-3

	Paragraph	Page
Planning	8-5—8-8	8-1
Reserve	8-13, 8-29, 8-36, 8-39, 8-40	8-6, 8-15, 8-20, 8-21
Staff	8-3	8-1
Support command (COSCOM)	7-57—7-58, 8-3, 8-5	7-30, 8-1
Tactical air support	8-15	8-6
Tactical operations center	8-4	8-1
Corps combat support:		
Army aviation	8-11, 8-20	8-4, 8-7
Chemical	8-20	8-7
Engineer	8-20	8-7
Long-range patrol elements	7-20, 8-20	7-16, 8-7
Military intelligence	8-20	8-7
Signal	8-20	8-7
USASA	8-20	8-7
Corps defensive operations:		
Allocation of combat power	8-37	8-20
Conduct of the counterattack	8-40	8-21
Counterattack planning	8-39	8-20
Covering force	8-34	8-19
Defensive echelons	8-33	8-18
Forms of defense	8-32	8-16
Forward defense area	8-35	8-19
Missions to subordinate units	8-38	8-20
Nuclear weapons	8-34, 8-36, 8-37, 8-39	8-19, 8-20
Reserve echelon	8-36	8-20
Security echelon	8-34	8-19
Corps offensive operations:		
Advance to contact	8-26	8-9
Coordination and control	8-24	8-9
Follow and support forces	8-30	8-15
Maneuver	8-28	8-9
Meeting engagements	7-36, 8-27	7-23, 8-9
Missions	8-23	8-8
Nuclear weapon employment	8-25	8-9
Reserve	8-29	8-15
Corps retrograde operations:		
Control	8-46	8-23
Covering force	8-43	8-21
Nuclear weapons	8-42, 8-43, 8-45	8-21, 8-22
Organization for combat	8-44	8-22
Planning	8-42	8-21
Supporting operations	8-47	8-23
Corps tactical operations center	8-4	8-1
Counterattack planning and execution:		
Corps	8-39, 8-40	8-20, 8-21
Field army	7-47	7-26
Covering force	7-42, 8-34, 8-43	7-25, 8-19, 8-21
Defensive operations:		
Allocation of combat power	7-45, 8-37	7-25, 8-20
Area defense	7-40, 8-32	7-24, 8-16
Counterattack	7-47, 8-39, 8-40	7-26, 8-20, 8-21
Echelons	7-41, 8-33	7-25, 8-18
Forms of defense	7-40, 8-32	7-24, 8-16
Forward defense echelons	7-43, 8-35	7-25, 8-19
Fundamental considerations	8-31	8-15
Missions to divisions	8-38	8-20

	Paragraph	Page
Mobile defense	7-40, 8-32	7-24, 8-16
Reserve echelon	7-41, 7-44, 7-47, 8-36, 8-39—8-40	7-25, 7-26, 8-20
Reserve echelon area	7-44, 8-36	7-25, 8-20
Security echelon	7-42, 8-34	7-25, 8-19
Denial operations	7-53	7-28
Department of Defense	3-2	3-1
Department of the Army	3-4	3-1
Divisions	7-10, 7-11, 8-10, 8-38	7-4, 7-5, 8-4, 8-20
Electronic warfare	7-19	7-14
Engineer employment:		
Corps	8-20, 8-44	8-7, 8-22
Field army	7-20, 7-50	7-16, 7-27
Envelopment	7-33, 8-28	7-22, 8-9
Envelopment, double	7-33, 8-28	7-22, 8-9
Exploitation	7-37	7-23
Field army:		
Allocation of combat power	7-10	7-4
Chemical and biological weapons	7-15	7-7
Combat service support	7-21, 7-22	7-17
Combat support	7-20	7-16
Command and staff actions	7-7	7-3
Headquarters	7-3	7-1
Missions	7-6	7-3
Nuclear weapons	7-7, 7-10, 7-12—7-14, 7-32, 7-34, 7-44	7-3, 7-4, 7-5, 7-22, 7-23, 7-25
Operation order	7-9	7-4
Organization	4-35, 7-2	4-12, 7-1
Phasing	7-8	7-4
Planning	7-5	7-3
Rear area protection	7-23	7-19
Reserve	7-13, 7-34, 7-35, 7-44, 7-47	7-6, 7-23, 7-25, 7-26
Stability operations	7-25—7-28	7-20
Staff	7-3	7-1
Tactical air support	7-16	7-8
Field army combat service support	7-21, 7-22, 7-50	7-17, 7-27
Field army combat support:		
Army aviation	7-20	7-16
Chemical	7-20	7-16
Engineer	7-20	7-16
Long-range patrol elements	7-20	7-16
Military intelligence	7-20	7-16
Psychological operations	7-20	7-16
Signal	7-20	7-16
USASA	7-20	7-16
Field army defensive operations:		
Allocation of combat power	7-45	7-25
Counterattack	7-47	7-26
Defensive echelons	7-41	7-25
Employment of reserve	7-47	7-26
Forms of defense	7-40	7-24
Forward defense area	7-43	7-25
Nuclear weapon employment	7-32, 7-46	7-22, 7-26
Reserve echelon	7-44	7-25
Security echelon	7-42	7-25

	Paragraph	Page
Field army offensive operations:		
Corps zones of action	7-31	7-22
Forms of maneuver	7-33	7-22
Meeting engagements	7-36	7-23
Missions to corps	7-30	7-22
Nuclear weapon employment	7-32	7-22
Reserve	7-34, 7-35	7-23
Field army retrograde operations	7-50, 7-51	7-27, 7-28
Field army tactical operations center	7-4	7-1
Fire support (See also nuclear weapons and chemical and biological weapons.)		
Corps	8-11	8-4
Field army	7-12	7-5
Naval gunfire and naval close air support	7-18	7-14
Fire support coordination line	6-10, 7-16, 8-11	6-4, 7-8, 8-4
Forms of maneuver	7-33, 8-28	7-22, 8-9
Forward defense area	7-43, 8-35	7-25, 8-19
Frontal attack	7-33, 8-28	7-22, 8-9
Functionally organized commands	3-17	3-9
Functions during combat	2-3	2-1
General war	1-1, 2-1	1-1, 2-1
Impact of nuclear, biological, and chemical operations	1-5	1-2
Independent corps	7-56—7-58, 8-1, 8-3, 8-5	7-30, 8-1
Intelligence	3-19, 5-2	3-9, 5-1
International standardization agreements	1-1, 3-10	1-1, 3-4
Joint Chiefs of Staff	3-3, 3-6—3-9, 3-21	3-1, 3-10
Letters of instructions	3-20, 4-1, 6-8, 7-6	3-10, 4-1, 7-3
Limited war	1-1, 2-1	1-1, 2-1
Meeting engagement	7-36, 8-27	7-23, 8-9
Military intelligence	3-19, 4-23, 4-24, 5-2, 7-16, 7-20, 8-20	3-9, 4-9, 5-1, 8-7
Military intelligence battalion, air reconnaissance support	7-16	7-8
Military intelligence group, theater army	4-23, 4-24	4-9
National Security Council	3-20	3-10
Navy and Marine Corps support	6-11, 7-18, 8-17	6-5, 7-14, 8-7
Nuclear weapons:		
Allocation	7-13, 7-14, 7-45, 8-12, 8-13, 8-25, 8-34, 8-39	7-6, 7-25, 8-5, 8-6, 8-9, 8-19, 8-20
Army group	6-12	6-5
Corps	8-11—8-13, 8-25, 8-29, 8-34, 8-36, 8-37, 8-39, 8-42, 8-43, 8-45	8-4, 8-9, 8-15, 8-19, 8-20, 8-21, 8-22
Employment	7-13, 7-14, 7-32, 8-12, 8-25, 8-34, 8-39, 8-42, 8-43, 8-45	7-6, 7-22, 8-5, 8-9, 8-19, 8-20, 8-21, 8-22
Field army	7-7, 7-10, 7-12— 7-14, 7-32, 7-34, 7-44	7-3, 7-4, 7-5, 7-22, 7-23, 7-25

	Paragraph	Page
Reserve	6-12, 7-13, 7-29, 7-34, 7-44, 8-13, 8-29, 8-36, 8-39	6-5, 7-6, 7-21, 7-23, 7-25, 8-15, 8-20
Vulnerability	1-5	1-2
Operational considerations:		
Corps	8-9—8-21	8-3
Field army	7-10—7-20	7-4
Operational environments	1-4	1-1
Penetration	7-33, 8-28	7-22, 8-9
Permission action link system (PAL)	3-8	3-2
Phasing	7-8, 8-7	7-4, 8-3
Planning:		
Army component	5-1—5-7	5-1
Army group	6-8	6-2
Corps	8-5—8-8	8-1
Field army	7-5—7-9	7-3
Retrograde operations	7-48—7-51, 8-41—8-43	7-27, 8-21
Theater	3-19—3-24	3-9
Planning guidance:		
Corps commander	8-6	8-3
Field army commander	7-5, 7-7	7-3
Psychological operations group, theater army:		
Capabilities and functions	4-33	4-11
General	4-31	4-11
Mission	4-32	4-11
Pursuit	7-37	7-23
Rear area protection (RAP)	7-22, 7-23	7-17, 7-19
Reserve:		
Army group	6-12	6-5
Corps	8-29, 8-36, 8-39, 8-40	8-15, 8-20, 8-21
Field army	7-11, 7-13, 7-34, 7-35, 7-44, 7-47	7-5, 7-6, 7-23, 7-25, 7-26
Nuclear weapons	7-13, 7-14, 7-34, 8-12	7-6, 7-23, 8-5
Reserve area	7-44, 8-36	7-25, 8-20
Retrograde operations	7-48—7-51, 8-41—8-47	7-27, 8-21
Secretary of Defense	3-2, 3-4, 3-6—3-9	3-1
Secretary of the Army	3-4, 3-5, 3-8	3-1, 3-2
Security Agency (See USASA.)		
Security echelon, defense	7-42, 8-34	7-25, 8-19
Separate corps	7-56—7-58, 8-1, 8-3, 8-5	7-30, 8-1
Service component forces	3-12	3-6
Shore-to-shore operations	6-11	6-5
Signal units:		
Corps	8-20	8-7
Field army	7-20	7-16
Special forces group, theater army	4-28—4-30	4-10
Special weapons (See nuclear, biological and chemical weapons.)		
Specific operational forces	3-17	3-9
Specified command	3-7, 3-10	3-2, 3-4
Stability operations	1-1, 2-1, 4-6	1-1, 2-1, 4-3

	Paragraph	Page
Tactical air reconnaissance	6-9	6-3
Tactical air support (<i>See</i> air support of ground operations.)	6-9—6-11, 7-16, 7-18, 8-15—8-17	6-3, 7-8, 7-14, 8-16
Tactical cover and deception	7-52	7-28
Territorial organization, theater of operations	3-11	3-4
Theater army:		
Combat service support	4-5	4-3
Command relationships	4-3	4-1
Commander	3-7, 4-3—4-5, 4-8—4-15, 4-18, 4-20, 4-25, 4-26, 4-31, 4-35, 5-1—5-7	3-2, 4-1, 4-4, 4-8, 4-10, 4-11, 4-12, 5-1
Communications system	4-20—4-22, 7-20	4-8, 7-16
Estimates	5-4	5-2
Intelligence	4-4, 5-2	4-3, 5-1
Major subordinate units	4-2, 4-14—4-35	4-1, 4-7
Organization	4-2	4-1
Other major units assigned or attached	4-36, 4-37	4-12
Planning	5-1—5-7	5-1
Staff	4-12	4-5
Theater army air defense brigade	4-14, 4-15	4-7
Theater army civil affairs command	4-25—4-27	4-10
Theater army commander (<i>See</i> subtopic under theater army.):		
Command	4-3, 4-8	4-1, 4-4
Relationship with collateral commands	4-11, 5-1—5-7	4-5, 5-1
Relationship with the Chief of Staff, U.S. Army	4-10	4-5
Relationship with the theater commander	4-9, 5-1—5-7	4-4, 5-1
Theater army planning:		
Basis	5-3	5-2
Coordination with other commands	5-7	5-2
Estimates	5-4	5-2
General	5-1	5-1
Information and intelligence	5-2	5-1
Operational directives	5-6	5-2
Scope	5-5	5-2
Theater army psychological operations group	4-31—4-33	4-11
Theater army special forces group	4-28—4-30	4-10
Theater army support command	4-16—4-19	4-7
Theater of operations:		
Command structure	3-12	3-6
Commander	3-7	3-2
Definition	3-6	3-1
Intelligence	3-19	3-9
Planning	3-19—3-24	3-9
Territorial organization	3-11	3-4
Turning movement	7-33, 8-28	7-22, 8-9
Unconventional warfare	7-55	7-30
Unified command	3-7, 3-10, 3-12	3-2, 3-4, 3-6
Uni-Service force	3-10, 3-12, 3-16	3-4, 3-6, 3-8
Unity of effort	3-9	3-4
USASA	4-37, 7-20, 8-20	4-12, 7-16, 8-7
U.S. Army Strategic Communications Command (Theater)	4-20—4-22	4-8

By Order of the Secretary of the Army:

WILLIAM C. WESTMORELAND,
General, United States Army,
Chief of Staff.

OFFICIAL:

KENNETH G. WICKHAM,
Major General, United States Army,
The Adjutant General.

Distribution:

To be distributed in accordance with DA Form 12-11 requirements for Field Service Regulations—Larger Units.