

PURCHASE DESCRIPTION

PANT, ARMY, COMBAT, FLAME RESISTANT

This Purchase Description is approved for use by DLA Troop Support and is available for use by all Departments and Agencies of the Department of Defense. (DoD)

1. SCOPE

1.1 Scope. This Purchase Description covers the requirements for combat pants with integrated kneepads to be worn by the Army.

1.2 Classification. The pant will be of one type and class, unless otherwise specified in a solicitation or contract.

1.2.1 Size. The pant sizes will be as follows and as specified:

SCHEDULE OF SIZES

X Small	Small	Medium	Large	X Large	XX Large
X Short	X Short	X Short			
Short	Short	Short	Short	Short	Short
Regular	Regular	Regular	Regular	Regular	Regular
Long	Long	Long	Long	Long	Long
			X Long	X Long	X Long

2. APPLICABLE DOCUMENTS

2.1 General. The documents listed in this section are specified in sections 3, 4, or 5 of this specification. This section does not include documents cited in other sections of this specification or recommended for additional information or as examples. While every effort has been made to ensure the completeness of this list, document users are cautioned that they must meet all specified requirements of documents cited in sections 3, 4, or 5 of this specification, whether or not they are listed.

Comments, suggestions, or questions on this document should be addressed to: US Army Natick Research, Development and Engineering Center, Attn: RDNS-WPC, 15 Kansas Street Natick, MA 01760-5019.

2.2 Government documents.

2.2.1 Specifications, standards, and handbooks. The following specifications, standards, and handbooks form a part of this document to the extent specified herein. Unless otherwise specified, the issues of these documents are those cited in the solicitation or contract.

FEDERAL SPECIFICATIONS

V-B-871 Button, Sewing, Hole and Button Staple (plastic)

FEDERAL STANDARDS

FED-STD-4 Glossary of Fabric Imperfections

COMMERCIAL ITEM DESCRIPTIONS

A-A-50198 Thread, Gimp, Cotton, Buttonhole
A-A-55126 Fastener Tape, Hook and Loop, Synthetic
A-A-55195 Thread, Para-Aramid, Spun, Intermediate Modulus
A-A-55217 Thread, Aramid, Spun, Staple

DEPARTMENT OF DEFENSE SPECIFICATIONS

MIL-DTL-32075 Label: For Clothing, Equipage, and Tentage (General Use)
MIL-PRF-5038 Tape, Textile and Webbing, Textile, Reinforcing Nylon
MIL-W-5664 Webbing, Textile Elastic

(Copies of these documents are available online at <https://assist.dla.mil/quicksearch/> from the Standardization Document Order Desk, 700 Robbins Avenue, Building 4D, Philadelphia, PA 19111-5094.)

2.2.2 Other Government documents, drawings, and publications. The following other Government documents, drawings, and publications form a part of this document to the extent specified herein. Unless otherwise specified, the issues are those specified in the solicitation or contract.

PURCHASE DESCRIPTIONS

GL/PD 07-12 Cloth, Flame Resistant
GL/PD 10-08 Patch Kit, Integrated, Flame Resistant (IPK)

(Copies of this document are available through the contracting activity.)

2.3 Non-Government publications. The following documents form a part of this document to the extent specified herein. Unless otherwise specified, the issues of these documents are those specified in the solicitation or contract. (See 6.2).

AMERICAN ASSOCIATION OF TEXTILE CHEMISTS AND COLORISTS (AATCC)

- AATCC Test Method 20 - Fiber Analysis: Qualitative
- AATCC Test Method 61 - Colorfastness to Laundering: Accelerated
- AATCC Test Method 81 - pH of the Water-Extract from Wet Processed Textiles
- AATCC Test Method 135 - Dimensional Changes of Fabrics After Home Laundering
- AATCC Evaluation Procedure 9 - Visual Assessment of Color Difference of Textiles

(Copies are available on line at <http://www.aatcc.org> or from the American Association of Textile Chemists and Colorists, P.O. Box 12215, Research Triangle Park, NC 27709-2215.)

AMERICAN SOCIETY FOR QUALITY (ASQ)

- ANSI/ASQ Z1.4 Sampling Procedures and Tables for Inspection of Attributes

(Copies are available on line at <http://www.asq.org> or from the American Society for Quality, 600 North Plankinton Avenue, Milwaukee, WI 53203)

ASTM INTERNATIONAL (ASTM)

- ASTM D 76 - Standard Specification of Tensile Testing Machines for Textiles
- ASTM D 737 - Standard Test Methods for Air Permeability of Textile Fabrics
- ASTM D 1424 - Standard Test Methods for Tearing Strength of Fabrics by Falling-Pendulum Type (Elmendorf) Apparatus
- ASTM D 1776 - Standard Practice for Conditioning and Testing Textiles
- ASTM D 1777 - Standard Test Method for Thickness of Textile Materials
- ASTM D 3773 - Standard Test Method for Length of Woven Fabrics
- ASTM D 3774 - Standard Test Method for Width of Textile Fabrics
- ASTM D 3775 - Standard Test Method for Warp End Count and Filling Pick Count of Woven Fabrics
- ASTM D 3776 - Standard Test Method for Mass Per Unit Area (Weight) of Fabric
- ASTM D 3787 - Standard Test Method for Bursting Strength of Textiles-Constant-Rate-of- Traverse (CRT) Ball Burst Test
- ASTM D 5034 - Standard Test Method for Breaking Strength and Elongation of Textile Fabrics (Grab Test)
- ASTM D 5169 - Standard Test Method for Shear Strength (Dynamic Method) of Hook and Loop Touch Fasteners
- ASTM D 5170 - Standard Test Method for Peel Strength (T Method) of Hook and Loop Touch Fasteners
- ASTM D 6413 - Standard Test Method for Flame Resistance of Textiles (Vertical Test)
- ASTM D 6193 - Standard Practice for Stitches and Seams

(Copies are available online at <http://www.astm.org> or from the ASTM INTERNATIONAL, 100 Barr Harbor Drive, P.O. Box C700, West Conshohocken, PA 19426-2959.)

PARACHUTE INDUSTRY ASSOCIATION (PIA)

PIA TEST METHOD-4108 Strength and Elongation Breaking; Textile Webbing,
Tape and braided material

(Copies of documents are available online at <http://www.pia.com> or the Parachute Industry Association, 3833 West Oakton St., Skokie, IL 60076.)

OTHER PUBLICATIONS

Repeat Insult Patch Test – Modified Draize Procedure
Principles and Methods of Toxicology (fourth edition), A. Wallace Hayes (editor), pp 1057 -
1060, 2001

(Copies are available online at <http://www.taylorandfrancis.co.uk/> or from Taylor and Francis, 325 Chestnut Street, Philadelphia, PA 19106.)

2.4 Order of precedence. Unless otherwise noted herein or in the contract, in the event of a conflict between the text of this document and the references cited herein, the text of this document takes precedence. Nothing in this document however, supersedes applicable laws and regulations unless a specific exemption has been obtained.

3. REQUIREMENTS

3.1 First article. When specified (see 6.2), a sample shall be subjected to first article inspection in accordance with 4.2.

3.2 Recycled, recovered or environmentally preferable materials. Recycled, recovered, or environmentally preferable materials should be used to the maximum extent possible, provided that the material meets or exceeds the operational and maintenance requirements, and promotes economically advantageous life cycle costs.

3.3 Materials.

3.3.1 Basic material. The basic material for the pant shall be a Flame Resistant (FR) twill cloth in Operation Enduring Freedom Camouflage Pattern (OCP) or other pattern as specified in a solicitation or contract, conforming to the physical requirements specified for Type IV of GL/PD 07-12 (see 6.2).

3.3.2 Stretch material. The cloth for the crotch gusset and knee adjustment tabs shall be an FR twill or plain weave cloth with two way stretch in Operation Enduring Freedom Camouflage

Pattern (OCP) or other pattern as specified in a solicitation or contract, conforming to the physical requirements listed in Table I, when tested as specified in 4.4.2, and all other requirements as specified for Type III of GL/PD 07-12 (see 6.2).

3.3.3 Abrasion resistant material. The cloth for the seat reinforcement panel shall be an FR twill cloth with abrasion resistant finish in Operation Enduring Freedom Camouflage Pattern (OCP) or other pattern as specified in a solicitation or contract, conforming to the physical requirements listed in Table I, when tested as specified in 4.4.2, and all other requirements as specified for Type III of GL/PD 07-12 (see 6.2).

TABLE I. Physical requirements

Characteristic	Requirement	
	Stretch Material	Abrasion Resistant Material
Weight, oz./sq.yd.		
Minimum	6.0	6.3
Maximum	7.0	7.3
Yarns per inch, (minimum)		
Warp	--	60
Filling	--	50
Breaking strength, pounds (minimum)		
Warp	--	110
Filling	--	100
Tearing strength, pounds (minimum)		
Warp	--	6.0
Filling	--	6.0
Bursting Strength, pounds (minimum)	125.0	--
Abrasion Resistance, cycles (minimum)	--	500
Dimensional Stability, percent (After laundering 5 cycles)(maximum)		
Warp and Filling:		
Individual Sample	--	4.0
Lot Average	6.0	3.5
Air permeability, cu.ft./min./sq.ft. (minimum)	25.0	--
Flame Resistance:		
Initial -		
After Flame, seconds (maximum)	2.0	2.0
After Glow, seconds (maximum)	15.0	15.0
Char Length, inches (maximum)	4.5	4.5

TABLE I. Physical requirements - Continued

Characteristic	Requirement	
	Stretch Material	Abrasion Resistant Material
Flame Resistance:		
After laundering -		
After Flame, seconds maximum)	2.0	2.0
After Glow, seconds (maximum)	15.0	15.0
Char Length, inches (maximum)	4.5	4.5

3.3.4 Cloth, side and hip hanging pockets, and waistband lining. The cloth for waistband lining, side and hip hanging pockets, shall be basic material, ground shade cloth or printed OCP seconds for OCP uniforms. For printed material, prior to overprinting the ground shade cloth shall Cream 524 for OCP uniforms in accordance with GL-PD 07-12. The ground shade shall meet the respective finished fabric physical, mechanical, and dimensional requirements. Seconds shall be cloth which has been rejected only for defects pertaining to color, infrared reflectance, or camouflage printed pattern as specified in or GL-PD 07-12 as applicable.

3.3.5 Waistband interlining. The cloth for the interlining shall be a nonwoven blend of polyester and cellulose (see 6.4). The total weight shall be no less than 1.35 ounces per square yard and no more than 2.2 ounces per square yard. The color shall be white and the hand shall be stable and medium stiff. The testing shall be as specified in 4.4.2.

3.3.6 Loop knee pad pocket facing. The cloth for the loop knee pocket facing shall be 100 percent brushed nylon weighing 8.0 ounces per square yard minimum (see 6.5). The thickness shall be 0.07-inches minimum and have 27 (± 2) courses per inch. The bursting strength shall be no less than 100 pounds minimum and shall have a dimensional stability of 5 percent maximum. The shear strength shall be 10 pounds per square inch minimum after 3 launderings and the peel strength shall be 1 pound per inch minimum after 3 launderings. The testing shall be as specified in 4.4.2.

3.4 Components. The color for all components in 3.4.1.1 through 3.4.1.4 and 3.4.2 through 3.4.6 shall match Tan 499 when tested as specified in 4.4.2.

3.4.1 Tape, cord and elastic

3.4.1.1 Hem tape (drawstring). The tape for the leg bottom hem shall conform to MIL-PRF-5038, Type III, 3/8-inch wide. The tape for attaching the barrel lock shall be cut approximately 2-inches in length so that when folded it finishes 3/4 ($\pm 1/8$) inch in length. The drawstring tape for the leg bottom hem shall be cut 29 (± 1) inches in length for all sizes. The tape ends shall be heat cut to prevent raveling and the ends of the bottom hem drawstring tape shall be finished with knotted ends.

3.4.1.2 Waist tab tape. The tape for the waist adjustment tabs shall be 1-inch wide and 4-inches long, conforming to Type III of MIL-PRF-5038. The tape ends shall be heat cut to prevent raveling.

3.4.1.3 Knee pad adjustment and pocket loop tape. The tape for the vertical knee pad adjustment and right front pocket loop shall be 3/4-inch wide conforming to Type III of MIL-PRF-5038. The tape ends shall be heat cut to prevent raveling. The tapes for the right front pocket loop and the knee pad adjustment buckle shall be 3-inches long. The tape lengths for the knee pad adjustment straps shall be as follows: X Small – 11 inches, Small – 12 inches, Medium – 13 inches, Large – 14-inches, X Large – 15-inches, XX Large – 16-inches .

3.4.1.4 Cord, elastic (drawcord). The elastic cord for the cargo pockets shall have a 1/8 (+1/32, -0) inch diameter. The elastic cord properties shall be as follows: weight 0.20 ounces per linear yard, elongation 120 (\pm 10) percent, 55 picks per inch minimum, 16 carriers, 3 ends/carrier, 12 elastic strands minimum and polyester cover yarn (see 6.4). The cord cut length shall be 14 (\pm 3/4) inches and shall be heat cut.

3.4.1.5 Elastic. The elastic for the waistband adjustment tabs shall be 1-inch wide and 2 1/2-inches long (+/- 1/8 inch), conforming to MIL-W-5664. Either Type I or Type II is acceptable.

3.4.2 Barrel lock. The barrel locks shall maintain a 3-pound minimum holding strength on elastic cord (see 3.5.1.3) when tested in accordance with 4.4.3. The barrel lock shall be 1/2-inch x 3/8-inch elliptical or 3/8-inch round shape, push-button size to easily operate with gloves. The barrel lock shall also provide/possess a separate fixed location for attachment of the webbings specified in 3.5.1.1 and 3.5.1.3. Barrel lock shall be set for customer use before packaging.

3.4.3 Fastener tape, hook and loop. The hook and loop fastener tape shall conform to Type II, Class 1 or Class 4 of A-A-55126. The widths shall be as specified for each application throughout this purchase description. The fastener tape, hook and loop, shall be consistent in manufacturer within a garment.

3.4.3.1 Fastener tape, hook and loop use. The use of hook and loop with and without selvage within a garment is allowed (does not need to be consistent within the garment). For hook and loop with selvage: slits, split edges or any splicing of fastener tape shall not be permitted. Hook and loop without selvage shall be heat slit along edges by hook and loop manufacturer only and shall not fray and shall meet the requirements of A-A-55126.

3.4.4 Thread. The thread for all seaming and stitching shall be as specified in Table II. All thread shall be non-staining and the requirements in each respective Commercial Item Description (CID) shall apply.

TABLE II. Thread requirements, all types

Component area	Thread specification	Needle thread (Tex size)	Bobbin/Looper thread (Tex size)
All seaming except small parts	A-A-55195, Type I	78	78
	A-A-55195, Type II	59	59
	A-A-55217, Type I	60	60
Bartacks, and small parts, (hook and loop, pockets, flaps, top stitching, tabs, hems and eyelets) and labels	A-A-55195, Type I	59	59
	A-A-55195, Type II	20	20
	A-A-55217, Type I	40	40
Overedge/Serge for raw edge cover	A-A-55195, Type I	39	39
	A-A-55195, Type II	16	16
	A-A-55217, Type I	40	40
Crotch seam, gusset and seat patch	A-A-55195, Type I	78	78
	A-A-55195, Type II	59	59
	A-A-55217, Type I	60	60
Button attachment	A-A-55195, Type I	59	59
	A-A-55195, Type II	39	39
	A-A-55217, Type I	40	40

3.4.5 Gimp. The cotton gimp for reinforcing buttonholes shall conform to A-A-50198, soft or glazed finish, Tex Size 180 or 210.

3.4.6 Buttons. Buttons shall be dull finish, 4 holes, 30 ligne conforming to V-B-871, Type II, Class D, Style 26. When attached to the pant, the button and thread shall withstand 40 pounds (minimum) when tested as specified in 4.4.2.

3.4.7 Patch Kit, Integrated (IPK). The IPK shall conform to the requirements of GL/PD 10-08. Operation Enduring Freedom Camouflage Pattern uniforms shall use Class 2, Size R.

3.4.8 Flat buckle. The kneepad adjustment tape shall be secured with a flat cam buckle, 3/4 inch width opening, outside width 1 inch. The color shall be black.

3.5 Design. The pants shall have a waistband with clean finished ends with seven (7) belt loops, hook/loop adjustment tabs, and button/buttonhole closure. The pants shall have a covered fly with three (3) buttons and buttonhole closure for larger sizes. The pants shall have two (2) side hanging pockets, two (2) back single welt hip pockets with two (2) button closure flaps, two (2) front side pleated cargo pockets with three (3) button/two (2) buttonhole closure flaps and two (2) lower leg pockets with hook and loop closure flaps. The cargo pockets shall have an elastic draw cord with barrel locks at the top hem. Both cargo pockets and lower leg pocket shall have sewn-in eyelets at the bottom of the bellows. The pants shall have a double needle seat patch, and a knee pad pocket on each leg and drawstring at each leg bottom (see 3.6.9). The knee pad pocket shall a

closure flap with hook/loop fasteners for use when the knee pad is not inserted. The pant shall have vertical and horizontal knee pad adjustments.

3.6 Construction. All material edges shall be clean finished, either, turned-in, turned-under or serged unless otherwise indicated. All components with a grain line shall follow the grain line of the basic garment material or as indicated on pattern.

3.6.1 Fastener tape, (hook and loop). All widths of hook and loop tape (see 3.5.4) shall be sewn 1/8 to 3/16 inch from bound selvage (for fastener tape with selvage) or from tape edge (for fastener tape without selvage) to prevent needle cutting along edges, stitching runoffs or improper fit into automatic sewing equipment. To prevent raveling on fastener tape with selvage, do not sew directly on the selvage. Under no circumstances shall any fastener tape be re-stitched for repair purposes. New tape shall be used for repairs to prevent needle cutting, thus offering maximum field life. All fastener tape maybe sewn through all layers on pant as indicated on the figures (see patterns for placement). Tolerance for all cut lengths of fastener tape shall be ($\pm 1/8$) inch.

3.6.2 Waistband. The finished waistband shall measure 2-1/4 (+ 1/8) inches wide with clean finished ends and a button/buttonhole closure. The width of the waistband shall be consistent so that the right and left sides match each other in width at the front within 3/16-inch. The waistband shall have side adjustment tabs, each consisting of a 1-inch by 2 1/2-inch length of elastic and a webbing tab with finished length of 4 1/2-inches. The elastic end of each tab shall be attached inside the waistband with a bartack placed below the side front belt loops. The webbing end of each tab shall have a 1-inch by 2-inch piece of hook tape on the side facing the waistband and shall be threaded to the outside of the waistband through a buttonhole placed beneath the side belt loop. A 1-inch by 4-inch piece of loop tape shall be centered on the waistband between the side and rear side belt loops.

3.6.3 Belt loops. The pant in sizes Small through XX Large shall have seven (7) belt loops measuring 3/4 ($\pm 1/8$) inch in finished width, and finish 2-1/2 ($\pm 1/8$) inches from top to bottom fold in the length. Fold is 3/8-inch below bottom of waistband. The belt loop placement shall be as indicated on the patterns. Front belt loops shall cover/hide the buttonholes and bartacks for the waist adjustment tabs. Belt loops may be positioned immediately adjacent to felled seams to reduce bulk in sewing.

3.6.4 Fly. The pant fly shall be a covered fly with three (3) buttons and buttonhole closure for all sizes. The buttonholes shall be horizontal and placed as indicated on the pattern. The fly shall have two rows of "J" stitching, 2 ($\pm 1/8$) inches from fly edge to outside needle. The top fly shall be edge stitched 1/16 to 1/8 inch. See Figure 1.

3.6.5 Seat patch. The pant shall have a double-needle seat patch (see pattern for placement). See Figure 1.

3.6.6 Knee pad pockets. The pant shall have a knee pad pocket on each leg, for removable, hard shell kneepads. The knee pad pocket shall be double needle stitched at the center seam and

shall be attached with double needle stitching. The opening shall have loop facing attached on the inside with double needle stitching and a flap with hook tape for closing the pocket when the knee pad is not in use. The hook tape on each side of the flap shall measure 5/8-inch by 5-inches and the hook tape across the top of the flap shall measure 5/8-inch by 3 1/4-inches. The bottom corners of the flap opening shall be reinforced with bartacks. The bottom edge of the pocket shall include a drain hole 3/4-inch (\pm 1/8 inch) in width, with reinforcing bartacks. The knee pad pockets shall have vertical adjustment tapes connecting the pocket to a flat buckle in the inside edge of the cargo pocket and horizontal adjustment tabs with hook fasteners inserted in the side seams to provide adjustment to corresponding loop fastener on the back of the knee area (see 3.6.8) for details on the adjustment tabs and tapes (see Figure 2).

3.6.7 Pockets and flaps. All pockets shall have eyelet drainholes as specified in the pattern and 3.6.11.2.

3.6.7.1 Front side pockets. The pant shall have two (2) front side hanging pockets with pocket openings measuring 6-3/4 (\pm 1/2) inches between bartacks. Pocket openings shall match each other within 1/4-inch. Any raw edge shall be overedge stitched.

3.6.7.2 Hip pockets. The pants shall have back left and right single welt hip pockets with a two (2) button/buttonhole closure per pocket. The finished welt shall measure 1/4 (\pm 1/16) inch. The welt opening shall measure 1/2 (\pm 1/16) inch. The buttons shall be sewn onto the outside of the pocket and the buttonholes shall be vertical and sewn into the underside of the flap as indicated on patterns (see Figure 3).

3.6.7.3 Cargo pockets and flaps. The pant shall have two (2) pleated bellows cargo pockets with flaps (see pattern for placement). The pockets shall have a sewn-in eyelet at the bottom side edge of bellow, as indicated on the pattern (see 3.6.10). The pockets shall have an elastic drawcord (see 3.4.1.3) inserted through eyelets at the top of pocket hem with a barrel lock (see 3.4.3) for adjustment. The barrel lock shall be attached to the inside of the cargo pocket with a piece of folded webbing (see 3.4.1.1). The elastic cord shall be securely fastened between both layers of fabric with two (2) bartacks (see Table VI). The elastic cord shall be threaded so that the tail of the elastic remains inside the pocket when cinched, shall be firmly clasped in the barrel lock with a single knot when closed and shall pull smoothly through barrel lock when open. The top of the folded finished pocket flaps shall finish 3/8-inch from the folded edge of pocket top (inside measurement, see pattern for placement). A 1-inch flat buckle shall be attached inside the pocket via a webbing loop inserted in the pocket flap seam. Finished length of the loop shall be 1-inch. The pleated bellows shall be edge stitched to secure pleat stability. The cargo pockets and flaps shall close with a three (3) button, two (2) buttonhole closure per pocket. The buttons shall be sewn onto the outside of the pocket and the buttonholes shall be vertical and sewn onto the underside of the flap as indicated on patterns. See Figure 4.

3.6.7.4 Lower leg pockets and flaps. The pant shall have two (2) lower leg bellows pockets with flaps (see pattern for placement). The pockets shall have a sewn-in eyelet at the bottom of the bellow, as indicated on pattern (see 3.9). The top of the folded finished pocket flaps shall finish 3/8 inch from the folded edge of pocket top (see pattern for placement). The pockets shall close

with one (1) piece of loop fastener tape cut 1-inch wide by 3-1/2 inches long sewn to the underside of pocket flap and two (2) pieces of hook fastener tape cut 1-inch wide by 1-inch long sewn to the outer side of pocket hem as indicated on pattern. See Figure 5.

3.6.8 Knee pad adjustment tabs/tapes.

3.6.8.1 Horizontal knee pad adjustment tabs. Horizontal adjustment tabs shall be attached in the inseam and outseam as indicated in the pattern. Attachment shall be reinforced with bartacks as indicated in Table VII. Hook tape 1 inch by 1-1/2-inches ($\pm 1/8$ inch) shall be attached to each tab 1/4-inch from the end and sides. Loop tape 1 inch wide shall be attached to the back leg as indicated in the pattern. The loop tape on the back of the knee shall be 1-inch wide with lengths as follows:

Garment Size	Loop Length (inches)
X-Small	8
Small	9
Medium	9 1/2
Large	10
X-Large	11
XX-Large	11 1/2

3.6.8.2 Vertical knee pad adjustment tapes. A flat buckle shall be attached to vertical adjustment tapes shall be attached to the top edge of the kneepad pocket inside the leg of the pant. The tape shall be threaded through a buttonhole placed as indicated in the pattern into the cargo pocket and attached to the flat buckle in the cargo pocket in order to provide vertical adjustment for the knee pads.

3.6.9 Leg bottom and hem. The pant leg bottoms shall be hemmed and shall have a drawstring inserted through two (2) sewn-in eyelets or two (2) 1/2-inch horizontal straight cut buttonholes with reinforcement piece as indicated on patterns (see 3.6.9 and 3.10.1). The drawstring tape (see 3.4.1.1) shall overlap (cross) between holes when threaded through the hem casing. The drawstring shall be heat sealed and knotted at each end before packaging. The finished hem shall measure 7/8 ($\pm 1/8$) inch wide on the outside.

3.6.10 Buttonholes. The buttonholes shall be eyelet-end tapered bar type worked over gimp for the fly, back hip welt pocket flaps, cargo pocket flaps and waistband with not less than four (4) tacking stitches at bar end catching the gimp ends (not counting the crossover stitch). The purling shall be on the outside surface. The cut lengths shall be set at 3/4-inch. The buttonholes shall be clean cut with the stitching securely caught in fabric. When buttonholes are used in lieu of sewn-in eyelets for the waistband and leg bottom hem drawstrings they shall be 1/2-inch, vertical, straight cut for the waistband and 1/2-inch, horizontal, straight cut for the leg bottom hem. Buttonholes for waistband and vertical knee pad adjustment tabs/tapes shall be 1-1/8 inch, vertical, straight cut.

3.6.11 Eyelets.

3.6.11.1 Cargo pocket bellows. The sewn-in eyelets for the cargo pocket bellows shall have a 1/4 (\pm 1/16) inch diameter finished opening.

3.6.11.2 Pocket drain holes. All pockets shall have sewn-in eyelets for drainage. The drain eyelets shall have a 1/4 (\pm 1/16) inch diameter finished opening. Placement of the drain eyelets shall be 1/4-inch above the bottom edge of the pocket unless otherwise noted on the pattern.

3.6.11.3 Leg bottom. When sewn-in eyelets are used for the leg bottom opening, they shall have a 3/8 (\pm 1/8) inch diameter finished opening.

3.6.12 Patch Kit, Integrated (IPK). The pant shall have an IPK placed into the finished left hip pocket, as worn. The IPK shall be placed into the pocket after permethrin treatment with the shortest dimension vertical and shall lie flat after placement in pocket. The pocket shall be secured with at least one button to prevent IPK from falling out.

3.7 Labels. Each pant shall have a combination identification/care label and a size label. The labels shall be sewn in labels conforming to Type VI of MIL-DTL-32075. The color of the labels shall be white. The printing for all labels shall be black. The inscription shall have a minimum font size of 8 points for the identification/care label only. The font for the size label shall be 10 points. The inscription legibility, label and label attachment shall last the expected life of the trouser.

3.7.1 Size label. The size label shall conform to Type VI, Class 2 of MIL-DTL-32075, and shall be sewn and caught in the bottom of the inside waistband seam. The stitching shall not cover the printing. The size label shall include the information in Table III for the applicable size.

TABLE IIIA. Size label information – smaller sizes

X Small – X Short Waist: Up to 27 in. Inseam: Up to 26 1/2 in. NSN No. NATO Size: 6067/5869	Small – X Short Waist: 27 to 31 in. Inseam: Up to 26 1/2 in. NSN No. NATO Size: 6067/6979	Medium – X Short Waist: 31 to 35 in. Inseam: Up to 26 1/2 in. NSN No. NATO Size: 6067/7989
X Small – Short Waist: Up to 27 in. Inseam: 26 1/2 to 29 1/2 in. NSN No. NATO Size: 6775/5869	Small – Short Waist: 27 to 31 in. Inseam: 26 1/2 to 29 1/2 in. NSN No. NATO Size: 6775/6979	Medium – Short Waist: 31 to 35 in. Inseam: 26 1/2 to 29 1/2 in. NSN No. NATO Size: 6775/7989
X Small – Regular Waist: Up to 27 in. Inseam: 29 1/2 to 32 1/2 in. NSN No. NATO Size: 7583/5869	Small – Regular Waist: 27 to 31 in. Inseam: 29 1/2 to 32 1/2 in. NSN No. NATO Size: 7583/6979	Medium – Regular Waist: 31 to 35 in. Inseam: 29 1/2 to 32 1/2 in. NSN No. NATO Size: 7583/7989
X Small – Long Waist: Up to 27 in. Inseam: 32 1/2 to 35 1/2 in. NSN No. NATO Size: 8390/5869	Small – Long Waist: 22 to 31 in. Inseam: 32 1/2 to 35 1/2 in. NSN No. NATO Size: 8390/6979	Medium – Long Waist: 31 to 35 in. Inseam: 32 1/2 to 35 1/2 in. NSN No. NATO Size: 8390/7989

TABLE IIIB. Size label information – larger sizes

Large – Short Waist: 35 to 39 in. Inseam: 26 1/2 to 29 1/2 in. NSN No. NATO Size: 6775/8999	X Large – Short Waist: 39 to 43 in. Inseam: 26 1/2 to 29 1/2 in. NSN No. NATO Size: 6775/9909	XX Large – Short Waist: 43 to 47 in. Inseam: 26 1/2 to 29 1/2 in. NSN No. NATO Size: 6775/0919
Large – Regular Waist: 35 to 39 in. Inseam: 29 1/2 to 32 1/2 in. NSN No. NATO Size: 7583/8999	X Large – Regular Waist: 39 to 43 in. Inseam: 29 1/2 to 32 1/2 in. NSN No. NATO Size: 7583/9909	XX Large – Regular Waist: 43 to 47 in. Inseam: 29 1/2 to 32 1/2 in. NSN No. NATO Size: 7583/0919
Large – Long Waist: 35 to 39 in. Inseam: 32 1/2 to 35 1/2 in. NSN No. NATO Size: 8390/8999	X Large – Long Waist: 39 to 43 in. Inseam: 32 1/2 to 35 1/2 in. NSN No. NATO Size: 8390/9909	XX Large – Long Waist: 43 to 47 in. Inseam: 32 1/2 to 35 1/2 in. NSN No. NATO Size: 8390/0919
Large – X Long Waist: 35 to 39 in. Inseam: 35 1/2 to 38 1/2 in. NSN No. NATO Size: 9098/8999	X Large – X Long Waist: 39 to 43 in. Inseam: 35 1/2 to 38 1/2 in. NSN No. NATO Size: 9098/9909	XX Large – X Long Waist: 43 to 47 in. Inseam: 35 1/2 to 38 1/2 in. NSN No. NATO Size: 9098/0919

3.7.2 Combination identification/care label. The combination identification/care label shall conform to Type VI, Class 15 of MIL-DTL-32075 and shall be placed on the inside of the right hip pocket as worn, so that the label shall face the wearer. The label shall be sewn on all four sides and the stitching shall not cover the printing or penetrate the trouser front. The label shall include the following information:

ARMY COMBAT PANT	
FLAME RESISTANT CONTRACT NO: W911QY-11-F-0148 FIBER CONTENT: 65% FR RAYON/25% P-ARAMID/10% NYLON STRETCH PANELS: 64% FR RAYON/25% P-ARAMID/10% NYLON/1% SPANDEX MADE IN USA CONTRACTOR: XXXXXXXXXXXXXXXX. LOT NUMBER: 1/	
This product meets the manufacturing and performance testing requirements as authorized by the Program Executive Office - Soldier	
	REMOVE KNEE PADS BEFORE CLEANING MACHINE WASH COLD OR WARM, PERM PRESS CYCLE TUMBLE DRY LOW OR MEDIUM HEAT USE DETERGENT ONLY, DO NOT USE SOAP DO NOT USE BLEACH, FABRIC SOFTENER OR STARCH DO NOT DRY CLEAN OR USE COMMERCIAL HOT PRESSING DO NOT IRON HOOK & LOOP FASTENERS LIGHTLY BRUSH HOOK & LOOP TO REMOVE DEBRIS
DO NOT REMOVE THIS LABEL THIS GARMENT IS FLAME RESISTANT	

1/ The lot number shall be stamped with indelible black ink prior to shipment.

3.7.3 Barcode label. Each pant shall have a barcode label conforming to Type VIII, Class 17 of MIL-DTL-32075. The label shall be Swift tacked in the side seam approximately 2 inches below the belt loop. The bar coding element shall be a 13 digit National Stock Number (NSN). There shall be a 12 digit Universal Product Code (UPC) number assigned for all NSNs by the contracting activity. The initials “UPC” must appear beneath the code. The bar code for NSN and UPC type shall be a medium to high density and shall be located so that it is completely visible on the pant when it is folded and/or packaged as specified and so it causes no damage to the pant.

3.8 Figures. The figures in this purchase description are furnished for informational purposes only. To the extent of any inconsistencies between the written document and the figure, the written document shall govern.

3.9 List of pattern parts. The Government shall furnish patterns, which show directional line markings for proper cutting and assembly, and are to be used as a guide for cutting contractor's working patterns. The Government patterns provide a seam allowance of 1/2-inch for outseams, seat seams, and crotch seams, 1/4-inch allowance for hip pocket flaps and 3/8-inch allowance for all other seams, except where otherwise specified. Pockets, pocket flaps, knee patches, hook and loop fastener tape, buttons, buttonholes, and bartacks shall be located in accordance with marks on patterns and table references. Minor modifications are permitted where necessary to accommodate manufacture's processes and use of automatic equipment. These modifications shall not alter the design, serviceability, appearance or finished measurements. The pattern list for the pant in Table IV is provided to insure that the pattern set provided is complete (see 6.2).

TABLE IV. List of pattern parts

Piece Name	Piece Description	Material	Cut
PD12_25-BACK_LOWER	Back Lower Leg	Base	2
PD12_25-BACK_UPPER	Back Upper Leg	Base	2
PD12_25-BACK_LEG_TAB	Back Leg Tab	Stretch	4
PD12_25-BELT_LOOP	Belt Loop	Base	1
PD12_25-CARGO_POCKET	Cargo Pocket	Base	2
PD12_25-CRGPKT_FACING	Cargo Pocket Facing	Base	2
PD12_25-CRGPKT_FLAP	Cargo Pocket Flap	Base	2
PD12_25-FLY_LFT_BTM	Fly Left Bottom	Base	1
PD12_25-FLY_LFT_TOP	Fly Left Top	Base	1
PD12_25-FLY_RIGHT	Fly Right	Base	1
PD12_25-FRONT_LOWER	Front Lower Leg	Base	2
PD12_25-FRONT_LEFT	Front Left	Base	1
PD12_25-FRONT_RIGHT	Front Right	Base	1
PD12_25-FRONT_POCKET	Front Pocket	Base	2
PD12_25-GUSSET	Gusset	Stretch	1
PD12_25-HIP_POCKET	Hip Pocket	Base	2
PD12_25-HIPPKT_FACNG	Hip Pocket Facing	Base	2
PD12_25-HIP_PKT_BR	Hip Pocket Bearer	Base	2
PD12_25-HIP_PKT_FLP	Hip Pocket Flap	Base	2
PD12_25-KNEEPTCH_FLP	Knee Patch Flap	Base	2
PD12_25-KNEEPATCH_IN	Knee Patch Inner	Base	2
PD12_25-KNEEPTCH_LOOP	Knee Patch Loop	Loop	2
PD12_25-KNEEPTCH_OUT	Knee Patch Outer	Base	4
PD12_25-KNEEPTCHSDOUT	Knee Patch Side Outseam	Base	2

TABLE IV. List of pattern parts - Continued

Piece Name	Piece Description	Material	Cut
PD12_25-KNEPTCHSDIN	Knee Patch Side Inseam	Base	2
PD12_25-LOWELEG_PKT	Lower Leg Pocket	Base	2
PD12_25-LOW_LEG_FLP	Lower Leg Flap	Base	2
PD12_25-SEAT_PATCH	Seat Patch	Abrasion Resistant	2
PD12_25-WSTBND_FUSE	Waistband Fusing	Fusible	1
PD12_25-WAISTBND_IN	Waistband Inner	Base	1
PD12_25-WAISTBND_OUT	Waistband Outer	Base	1
PD12_25-KNEEOUT_TEMP	Knee Patch Out Template	n/a	Template
PD12_25-KNEPTCH_TEMP	Knee Patch Template	n/a	Template

3.10 Configuration. Each pant shall conform to appearance (see Figures 1-7), the finished measurements in Table VII (as applicable) and the construction methods specified in 3.10.1 through 3.10.2 and Table V in order to maintain configuration compliance.

3.10.1 Seams and stitching. All seams shall be consistent and exhibit a uniform appearance and conform to the ASTM D 6193 seam and stitch types listed in Table V. The backside of seams (inside garment) shall be flat with no protruding seam allowance to create irritation or discomfort. All material edges shall be clean finished, either, turned-in, turned-under or serged. All pocket flaps shall be serged prior to setting. Needle and bobbin thread tension shall be balanced such that neither is too tight nor too loose relative to each other. The seams for all outside visible stitching shall be sewn with 11 (\pm 1) stitches per inch. Overedge or pre-hemming shall be 8 (\pm 2) stitches per inch. Hook and loop tape shall be sewn with 10 (\pm 2) stitches per inch. Buttons shall be attached with 16 stitches per button. The sewn eyelets for the bellows pockets shall have a minimum of 16 stitches. All stitches per inch and gauges shall be met prior to treatment.

3.10.1.1 Fly seaming and stitching. The fly construction stitching of front center crotch seam shall end at J-stitch. There shall be a horizontal bartack superimposed on the bottom point of the J-stitch. The bartack shall be placed a minimum of 1/4 inch below the lowest button/ buttonhole (see Figure 6).

TABLE V. Seam and stitching types

Seam Placement	Seam type	Gauge	Stitch type
Side seams, back seam and inseam	LSg-3	Connecting stitch Topstitch 3/16 to 9/32-inch gauge	301 401
	SSa-1	Overedge before topstitching above, 1/8 to 3/16-inch gauge	504
Top stitching of pocket flaps and side pockets	OSf-1	3/16 to 1/4-inch from edge	301
Attachment of pockets	LSd-1	1/16 to 1/8-inch from edge	301
Raw edges of pocket flaps, pocket bagging, bearer or facings	Ssa-2	1/4 to 3/8-inch gauge	516, 519
Attachment of knee patches	LSd-2	Two rows 3/16 to 1/4-inch apart	301
Bottom hemming	Efb-1	3/4 to 1-inch wide hem	301
Waistband attachment	LSbc-2	1/16 to 1/8- inch from top and bottom edge of waistband	301 or 401
Waist adjustment tabs <u>1/</u>	LSbj-1	Box stitch 3/4-inch by 3/4-inch to attach webbing to elastic. Box stitch 1-7/8 inches by 3/4-inch to attach hook to webbing.	301
Hook and loop	LSbj-1	1/8 to 3/16-inch from the bound selvage	301
Cargo and lower Leg Pocket bellows, pleats edge stitch all	OSf-1	1/16 to 1/8-inch from edge	301
Seat patch	LSd-2	Two rows 3/16 to 1/4-inch apart. First row of stitching shall be 1/16 to 1/8-inch from folded edge	301
Buttonhole fly – join pieces along front edge; turned in edge	SSe-2 or SSc-1	1/16 to 1/8-inch from turned in edge	301
Join left front and left fly lining along front edge; turned in edge	SSe-2 or SSc-1	1/16 to 1/8-inch from turned in edge	301
Overedge back edges of left fly lining and buttonhole fly	EFd-1	3/16 to 1/4-inch gauge	502, 503 or 504
J-stitch	LSbj-1	2 (\pm 1/8) inch from edge	301
Join right front and right fly lining along front edge	SSe-2 or SSc-1	1/16 to 1/8-inch from turned in edge	301
Overedge right fly raw edges	EFd-1	3/16 to 1/4-inch gauge	502, 503 or 504

TABLE V Seam and stitching types – Continued

Seam Placement	Seam type	Gauge	Stitch type
Crotch gusset	LSb-2	Two rows 3/16 to 1/4-inch apart. Stitching shall penetrate both crotch pattern pieces. See Figure 7.	301
Crotch seam	LSq-1	Join front crotch with single needle.	301

3.10.2 Bartacking. To maintain garment durability and functionality, bartacks shall be placed as specified in Table VI. Bartacks shall be 1/8 to 3/16-inch wide.

TABLE VI. Bartack placement

Bartack Placement	Size of Tack (inches)	Stitches per Tack	# of Bartacks per Side or Piece
All pocket flaps, except back hip pocket flap, at top on ends of topstitching (horizontal)	1/2	31-36	2
Top and bottom of all belt loops (set 1/8-inch from edge) (horizontal)	3/4	40-44	2
Fly front			
a. Horizontal, superimposed on bottom point of J-stitch of fly outside (through all layers), minimum 1/4-inch below lowest button/buttonhole	1/2	31-36	1
b. Vertical or angled, with lower end approximately 1/4-inch from base of right fly and 1/2-inch from front edge of right fly (through all fly layers not visible from front)	1/2	31-36	1
Buttonhole, fly to left front lining (horizontal)			
a. Between the second and third buttonholes	1/2	31-36	1
b. Between the third and fourth buttonholes	1/2	31-36	1
Bottom of knee patch flap opening superimposed on top stitching (horizontal)	1/2	31-36	2
Drain hole at bottom edge of knee pad pocket, 1/2 to 3/4 inch apart, space centered on knee pad pocket center seam	1/2	31-36	2

TABLE VI. Bartack placement - Continued

Bartack Placement	Size of Tack (inches)	Stitches per Tack	# of Bartacks per Side or Piece
Top of knee pad pocket opening, centered on center seam and superimposed on topstitching (horizontal)	1/2	31-36	2
Waist band to secure elastic end of adjustment tab (vertical) – under front belt loops	1	55-60	2
Front hanging pocket opening, (meeting or overlapping pocket edge) two (2) bartacks as follows:			
a. Top opening, superimposed on waistband topstitching (horizontal)	1/2	31-36	1
b. Bottom, superimposed on side seam topstitching (vertical)	1/2	31-36	1
Cargo pocket, place three (3) vertical bartacks as follows:			
a. Top front corner	1/2	31-36	1
b. Top back corner	1/2	31-36	1
c. Anchoring barrel lock webbing, center 1-1/4 inch below top back corner	1/2	31-36	1
End of cargo pocket elastic cording, two (2) bartacks 1/4 inch apart (vertical) (through face side of pocket with cord inserted between both layers)	1/2	31-36	2
Cargo pocket pleats superimposed on facing stitching (horizontal)	1/2	31-36	2
Lower Leg Pocket (vertical)			
a. Top left	1/2	31-36	1
b. Top right	1/2	31-36	1
c. Lower corner (opposite side of bellows)	1/2	31-36	1
Back hip pocket at welt ends (vertical), superimposed on stitch line	1/2	31-36	2
Center back of leg bottom hem (vertical), securing lace (line tack also permitted)	1/2	31-36	1
Crotch/gusset junction, superimposed on gusset topstitching, through center of crotch seam	1/2	31-36	2
Knee adjustment tabs, superimposed on topstitching close to seam.	1/2	31-36	2

3.11 Finished measurements. The finished pants shall conform to the measurements listed in Table VII.

TABLE VII. Finished measurements (inches)

Size	XS	S	M	L	XL	XXL	Tol.
1/2 Waist, 1/	13-3/4	15-3/4	17-3/4	19-3/4	21-3/4	23-3/4	± 1/2
Inseam, 2/							
X-Short	28	28	28	-	-	-	
Short	30	30	30	30	30	30	
Regular	32	32	32	32	32	32	± 3/4
Long	34	34	34	34	34	34	
X-Long	-	-	-	36	36	36	
Outseam, 3/							
X-Short	35-1/4	35-3/4	36-1/4	-	-	-	
Short	37-3/4	38-1/4	38-3/4	39-1/4	39-3/4	40-1/4	
Regular	40-1/4	40-3/4	41-1/4	41-3/4	42-1/4	42-3/4	± 3/4
Long	42-3/4	43-1/4	43-3/4	44-1/4	44-3/4	45-1/4	
X-Long	-	-	-	46-3/4	47-1/4	47-3/4	
1/2 Leg Opening 4/	8-1/2	8-1/2	8-7/8	8-7/8	9	9-1/2	± 1/2

NOTE: The garment shall be buttoned, placed flat upon a table and measured as follows:

1/ 1/2 Waist - With adjustment tabs relaxed, measure along center of waistband from outside folded edge to folded edge.

2/ Inseam - Measure inseam of pants from point where front crotch seam joins the gusset to bottom edge of pant along the inseam.

3/ Outseam - Measure from top edge of waistband to bottom of leg along outseam.

4/ Leg Opening - Measure across bottom of leg from outside folded edge to inside folded edge.

3.12 Toxicity. The finished pant shall not present a health hazard and shall show compatibility with prolonged, direct skin contact when tested as specified in 4.4.3. Chemicals recognized by the Environmental Protection Agency (EPA) as human carcinogens shall not be used.

3.12.1 Toxicity documents. Finishes/chemicals used in the process of this garment shall be identified and accompanied by the appropriate Material Safety Data Sheet (MSDS) information.

3.13 Workmanship. After completion of the final assembly, the pant shall be thoroughly cleaned and all thread scraps, lint and foreign matter shall be removed and all closures engaged prior to packaging. The pant shall be uniform in quality and shall be free from irregularities or defects which could adversely affect fit, performance, reliability or durability. The pant shall conform to the quality established by this purchase description.

4. VERIFICATION

4.1 Classification of inspection. The inspection requirements specified herein are classified as follows:

- a. First article inspection (see 4.2).
- b. Conformance inspection (see 4.3).

4.2 First article inspection. First article, submitted in accordance with 3.1 shall be inspected for design, configuration in Tables V and VI and overall workmanship. The first article shall also include the finished measurements in Tables VII, examination for defects in Table VIII, and testing in Tables IX and X. The presence of excessive defects, as defined in the contract (see 6.2) or failure of any testing shall be cause for rejection of the first article.

4.3 Conformance inspection. Conformance inspection shall include shade and appearance of all components, finished measurements in Tables VII, examination for defects in Table VIII and testing in Tables IX and X. Sampling for inspection shall be performed in accordance with ANSI/ASQ Z1.4, as defined by contract, except where otherwise indicated.

4.4 Component and end item inspections. In accordance with 4.3, components and end items shall be tested in accordance with all the requirements of referenced documents unless otherwise excluded, amended, modified or qualified in this document or applicable procurement documents. The Government reserves the right to inspect and test all components and end items to determine conformance to requirements.

4.4.1 End item visual examination. Each pant shall be subjected to visual examination. All fabric and garment defects shall be scored in accordance with Table VIII, which are clearly noticeable at normal viewing distance (3 feet) and affect serviceability and appearance of the garment. Material defects are defined in Section I of FED-STD-4. If needed, closer inspection will be performed to verify compliance to specification requirements.

TABLE VIII. End item visual examination

Examination	Defect	Classification	
		Major	Minor
Material	Incorrect, not as specified (see 3.3.1 and 3.3.1.1)	101	
	Hole, cut, tear, smash, burn, needle chew, exposed drill hole, run, thin place, dye streak, color not as specified, misweave, visible mend	102	
	Knots greater than Sears Scale Level C (See 6.6)		201
	Slubs greater than Sears Scale Level D (See 6.6)		202
Shade	Shade variation within part or between parts of pant, affecting appearance or serviceability	103	
Components	Component not in accordance to the specification	104	
Tape, Cord, and Braid	Any tape or cord distorted, full, tight, or twisted		203
Barrel Lock	Misplaced or omitted	105	
	Color or type not as specified		204
Fastener Tape, Hook and Loop	Misplaced, damage, frayed, spliced or omitted	106	
	Color or type not as specified		205
	Tape piece edges not cut straight (at approximately 90 degrees)		206
Elastic Webbing	Misplaced, damage, frayed, spliced or omitted	107	
	Color or type not as specified		207
Thread/Gimp	Color or type not as specified		208
Buttons	Damaged or ragged	108	
	Not specified type, size or color		209
Patch Kit	Omitted	109	
	Not placed in correct pocket or position		210
	Patch color, type or packaging not as specified		211
Labels, Hangtags, Bar code/UPC/HRI Codes	Omitted, incorrect, illegible,	110	
	Color or type not as specified		212
	Human readable interpretation (HRI) illegible	111	
Construction	Any construction part of the pant omitted (3.6.1 to 3.6.12)	112	
Fastener tape, hook and loop	Twisted or distorted when closed	113	
	Out of alignment causing bulge		213
	Joining pieces out of alignment with each other by more than 1/4-inch	114	
	Not stitched to pant as specified	115	
	Stitching on tape selvage rather than hook or loop	116	
	Tape stitched less than 1/8 inch or more than 3/16 inch from edge	117	

TABLE VIII. End item visual examination - Continued

Examination	Defect	Classification	
		Major	Minor
Waistband and adjustment tabs	Incorrect design, not specified or specified as in patterns, not secured, not specified width, Waistband grain lines not matching to pant	118	214
	Waistband button/buttonhole alignment uneven by more than 1/4-inch when buttoned	119	
	Waistband adjustment tabs omitted	120	
	Waistband adjustment tabs not constructed as specified		
Belt loops	Belt loops omitted, not secured, not specified size, opening not as specified or incorrect placement, belt loop bartack goes through elastic of waistband adjustment tab	121	
Fly	Incorrect design not specified in patterns, not secured, missing or skewed J stitch line	122	
Seat Patch	Seat Patch omitted	123	
	Not attached as specified, not aligned at top more than 1/4-inch	124	
Knee Patch	Knee Patch omitted, not attached as specified, opening not as specified	125	
Pocket and Flaps (all)	Pocket construction and openings not as specified	126	
	Pocket companions and openings not uniform in size or shape by 1/4-inch	127	
	Pocket flaps or openings not as specified	128	
	Pocket flaps twisted, curled or puckered, not stitched as specified or not well formed	129	
	Pocket flaps not completely covering pocket opening left to right, positioned or grain line not as specified	130	
	Pocket flap finished uneven from left to right more than 1/4-inch	131	
Front Hanging Side Pockets	Raw edge not overedged	132	
Hip Pocket	Omitted, or incorrect size	133	
	Missing or incorrect placement of eyelet, hook and loop	134	
Cargo Pockets	Omitted or incorrect size	135	215
	Missing edge stitch on pleats, missing or incorrect placement of eyelet, hook and loop, barrel lock, or cord		

TABLE VIII. End item visual examination - Continued

Examination	Defect	Classification	
		Major	Minor
Barrel locks/cord	Incorrect placement of barrel lock,	136	216
	Barrel lock not secured/set,	137	
	Barrel lock not functional	138	
	Barrel lock cord not knotted properly and secured		
Lower Leg Pockets	Omitted or incorrect size	139	217
	Missing or incorrect placement of eyelet, or hook and loop		
Hem/Bottom opening/Inseam and Outseam	Hem not as specified, or missing drawstring	140	
	Bottom openings varying more than 1/2-inch in width	141	
	Inseam and outseam lengths varying by more than 1/2-inch	142	
Eyelets	Omitted, misplaced or incorrect size	143	218 219
	Loose stitching, incorrect number of stitches		
	Eyelet hole not cut through		
Bartacks	Omitted, misplaced or incorrect size	144	220
	Loose stitching, incorrect number of stitches		
Buttonholes	Omitted, misplaced or incorrect size	145	221 222
	Button holes not in specified direction		
	Loose buttonhole thread, purling on wrong side, not clean cut or securely caught in fabric	146	
	Alignment of buttonholes and buttons causing bulge, twist or distortion when engaged	147	
Labels/ Hangtags/ UPC/HRI Codes	Size, combination identification/care labels not placed correctly		223
	Hangtags/UPC labels not placed securely attached in correct position		224
	Barcode/UPC code not visible on folded, packaged item		225
	Any label or tag having incorrect printed content	148	
	Any label, hangtag, or barcode attachment causing damage to item	149	
Seams and Stitching	Open seams, puckered, distorted, wavy, twisted, or irregular	150	226 227
	Loose or tight stitch tension		
	Less than 1/2-inch in length		
	Greater than 1/2-inch in length	151	
	Missing stitches greater than 1/4-inch length	152	
	Edge or raised stitching sewn too close to the edge or needle chew resulting in damage to fabric over 1/4-inch in length		
	Seam allowance not as required by stitch type	153	

TABLE VIII. End item visual examination - Continued

Examination	Defect	Classification	
		Major	Minor
Seams and Stitching, continued	Visible raw edge on outside of pant (inside raw edge greater than 1-inch)	154	
	Stitching not as specified	155	
	Double needle intersecting seams staggered by more than 1/4-inch	156	
	Run off of stitching more than 1/2-inch for edge or raised stitching	157	
	Stitching caught in components or fabric causing unwanted permanent folds, pleats or fullness in the garment	158	
	Free floating stitching not secured in a seam or other stitching by less than 1/4-inch or ends of a continuous line of stitching not overlapped over 1/2-inch (except label stitching)	159	
	Stitching of seams incorrectly repaired	160	
Cleanness/ Workmanship	Spot/Stain affecting appearance or serviceability	161	
	Odor	162	
	Excessive thread ends (more than 3) Between 1/4 to 1-1/2 inch		228
	Excessive thread ends (more than 3) Over 1-1/2 inches	163	
	All closures on pant not engaged		229
Packaging	Any pant not package in accordance with contract or purchase order		230

4.4.2 Component testing. The components (see 3.3.2, 3.3.3 and 3.4.1.4) shall be tested for the characteristics listed in Table IX. The methods of test shall be as specified in Table IX. All test reports shall contain the individual values utilized in expressing the final results. The testing requirements and test sampling plan shall be as specified in the contract or purchase order.

TABLE IX. Component tests

Characteristic	Requirement paragraph	Test method
Material 3.3.2 and 3.3.3		
Weave	3.4	Visual
Weight	Table III	ASTM D-3776 (Method C)
Yarns per Inch	Table III	ASTM D-3775
Breaking Strength	Table III	ASTM D-5034 (G-E or G-T)
Tearing Strength	Table III	ASTM D-1424
Abrasion Resistance	Table III	ASTM 3884, H18 Wheel, 250g/Weight

TABLE IX. Component tests - Continued

Characteristic	Requirement paragraph	Test method
Material 3.3.5		
Dimensional Stability (After 5 cycles)	Table III	AATCC-135, 3, V, Aiii
Air Permeability	Table III	ASTM D-737
Flame Resistance Initial After laundering (25 cycles)	Table III Table III	ASTM D-6413 AATCC-135, 3, V, Aiii and ASTM D 6413
Weave	3.3.5	Visual
Fiber Content	3.3.5	AATCC 20
Weight	3.3.5	ASTM D-3776 (Method C)
Material 3.3.6		
Yarn construction	3.3.6	Visual
Fiber Content	3.3.6	AATCC 20
Weight	3.3.6	ASTM D-3776 (Method C)
Thickness, inches	3.3.6	ASTM D 1777
Courses per inch	3.3.6	ASTM D 3774
Bursting Strength	3.3.6	ASTM D 3787
Dimensional Stability	3.3.6	AATCC 135 3,V,Aiii
Shear Strength, lbs./sq. inch (Minimum) After 3 launderings	3.3.6	ASTM D 5169 AATCC 61 Test 3A
Peel Strength lbs./inch (Minimum) After 3 launderings	3.3.6	ASTM D5170 AATCC 61 Test 3A
Cord, elastic: (All Types)		
Width/diameter	3.5.1.3	Visual/micrometer
Weight (oz./lin. yd.)	3.5.1.3	ASTM D 3776
Elongation	3.5.1.3	1/
Picks/inch	3.5.1.3	ASTM D 3775
# of carriers	3.5.1.3	Visual
Ends/per carrier	3.5.1.3	Visual
# of strands	3.5.1.3	Visual
Color shade matching	3.5.1.3	AATCC Evaluation Procedure 9, Option A

1/ Elastic cord elongation test. Cut a 14-inch specimen from a representative sample cord and make two marks on the cord so that a distance of 10-inches is between the gauge marks. Suspend the cord from a clamp in such a manner as to allow a 2-pound weight to be hung on the lower end of the cord. Gradually lower the weight until the entire load is carried by the cord.

After 2 minutes, take a measurement between the two marks and calculate the increase in length as follows:

$$\text{Elongation (\%)} = \frac{B-A}{A} \times 100$$

Where:

A = Initial measurement

B = Measurement of elongation at 2 pounds

4.4.3 End item testing. The finished pant shall be tested for the characteristics listed in Table X. The methods of test shall be as specified in Table X. All test reports shall contain the individual values utilized in expressing the final results. The testing requirements and test sampling plan shall be as specified in the contract or purchase order.

TABLE X. End item tests (all Types)

Characteristic	Requirement paragraph	Test method
Barrel lock (All Types) (Class 2 prior to treatment)	3.4.2	4.5.1
Button pull/break (All Types) (Class 2 prior to treatment)	3.4.6	ASTM D 5034
Toxicity (All Types)	3.12	4.5.2

4.5 Methods of Inspection.

4.5.1 Barrel lock test. The barrel lock holding strength shall be tested as follows:

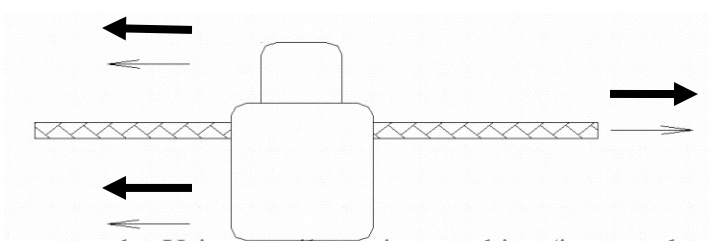

Barrel lock holding strength: Using tensile testing machine (in accordance with ASTM D 5034) at 2 inches/minute, either pull-up cord on stationary engaged cord-lock or vice-versa (see above illustration.).

4.5.2 Toxicity test. If the toxicity requirement (see 3.12) can be demonstrated with historical data, toxicity testing may not be required (see 6.2). When required, (see 6.2), an acute an acute dermal irritation study and a skin sensitization study shall be conducted on laboratory animals. When the results of these studies indicate the pant is not a sensitizer or irritant, a Repeat Insult Patch Test shall be performed in accordance with the Modified Draize Procedure. (See 2.3)

5. PACKAGING

5.1 Packaging. For acquisition purposes, the packaging requirements shall be as specified in the contract or order (see 6.2). When packaging of material is to be performed by DoD or in-house personnel, these personnel need to contact the responsible packaging activity to ascertain packaging requirements. Packaging requirements are maintained by the Inventory Control Point's packaging activities within the Military Service or Defense Agency, or within the military service's system command. Packaging data retrieval is available from the managing Military Department's or Defense Agency's automated packaging files, CD-ROM products, or by contacting the responsible packaging activity.

6. NOTES

(This section contains information of a general or explanatory nature that may be helpful, but is not mandatory.)

6.1 Intended use. The pant is for wear by military personnel in the United States Army as a combat uniform in garrison and combat missions.

6.2 Acquisition requirements. Acquisition documents should specify the following:

- a. Title, number and date of this Purchase Description document.
- b. Sizes required (see 1.2).
- c. The specific issue of individual documents referenced (see 2.2).
- d. When first article is required (see 3.1, 4.2, 6.3).
- e. Pattern required (see 3.10)
- f. When toxicity testing is required (see 3.13)
- g. Conformance inspection acceptance quality limits (AQL) (see 4.3).
- h. Inspection conditions (see 4.4).
- i. Packaging (see 5.1).

6.3 First article. When a first article is required, it shall be inspected and approved under the appropriate provisions of FAR 52.209-4. The first article should be a pre-production sample. The contracting officer should specify the appropriate type of first article and the number of units to be furnished. The contracting officer should include specific instructions in all acquisitions documents regarding arrangements for selection, inspection and approval of the first article.

6.4 Staflex ® 4038 from Harodite Finishing Company, Inc., 66 South Street North Dighton, MA 02764 US, (508) 824-6961, <http://www.harodite.com>, is known to meet the requirements of 3.3.5.

6.5 Vendor item # QL9000 from Propel LLC 189 Governor Street Suite 103, Providence, RI 02906, <http://www.propel-llc.com>, is known to meet the requirements of 3.3.6.

6.6 Fabric defect scales. Fabric Defect Replica Kits are available from Sears Roebuck and Co., “Fabric Defect Replica Kit” at SHGS Hong Kong Textile Testing Laboratory, 49/F, Office Tower, Langham Place, 8 Argyle Street, Mongkok, Kowloon, Hong Kong

6.7 Subject term (key word) listing.

Clothing

Clothing, Flame Retardant

Clothing, Flame Resistant

Operation Enduring Freedom Camouflage Pattern (OCP)

FIGURE 1. Pant, Army Combat

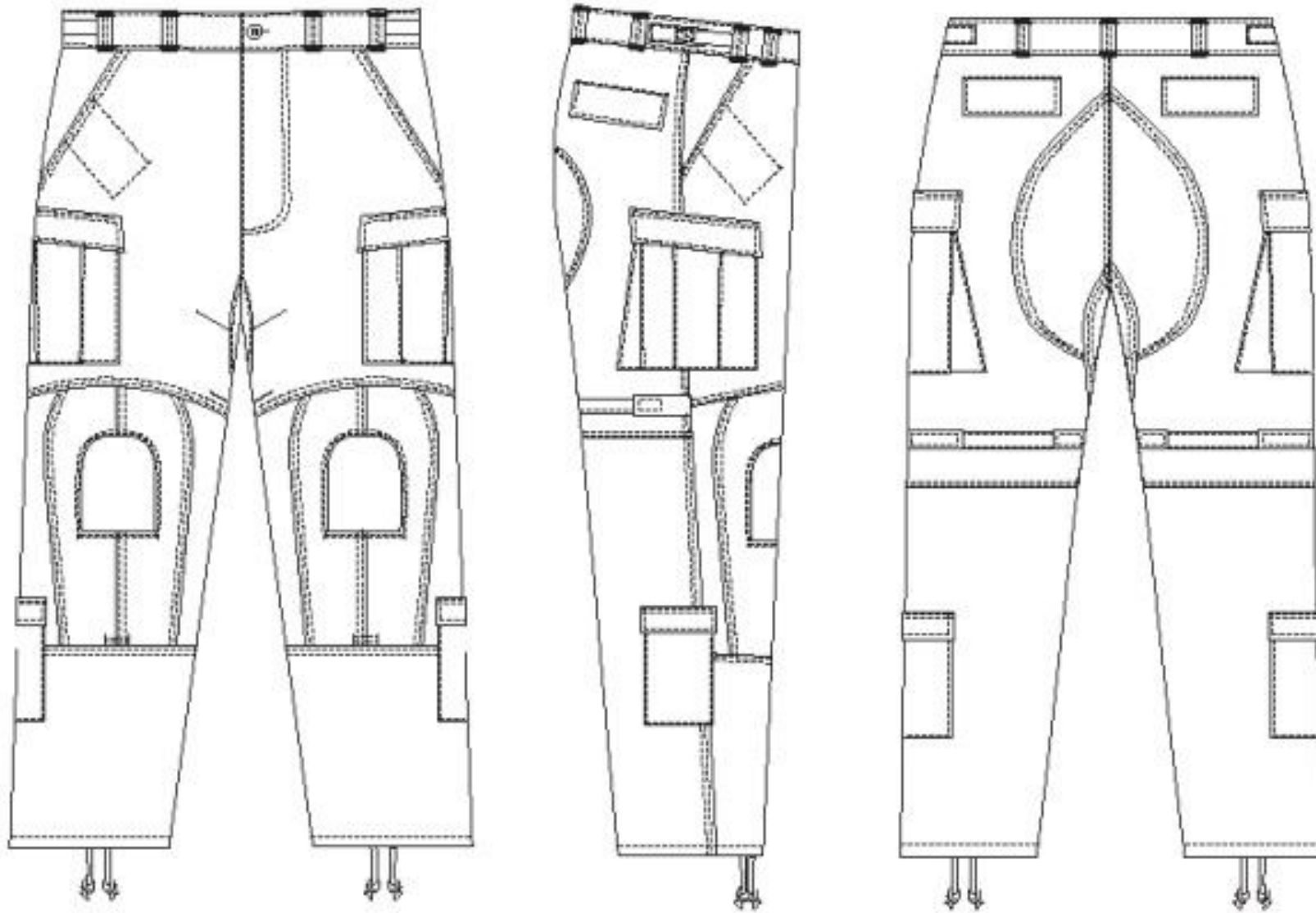

FIGURE 2. Pant, Army Combat, knee pad pocket

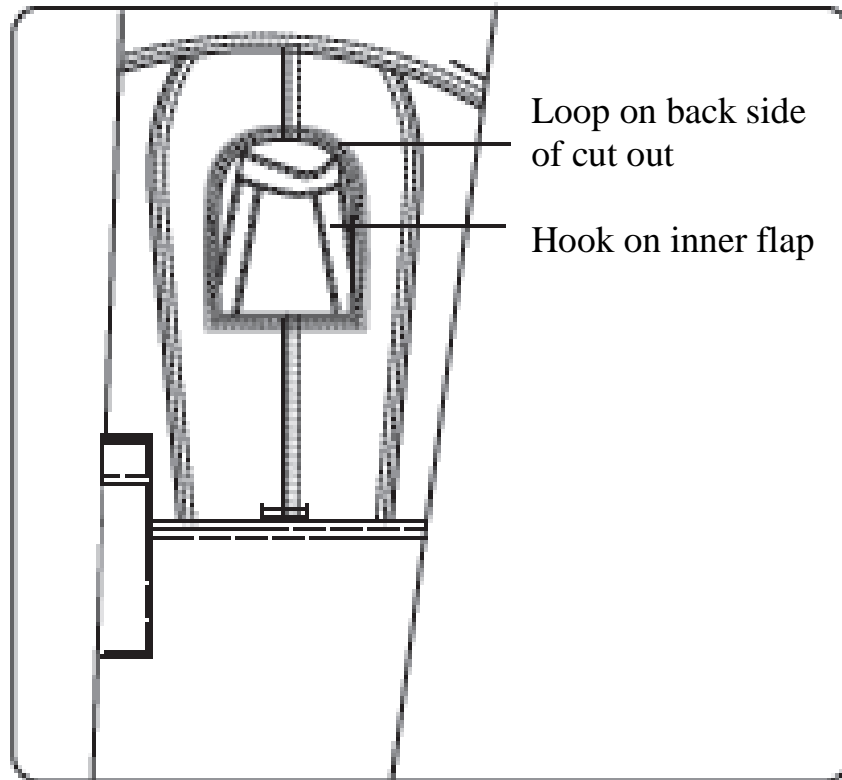

FIGURE 3. Pant, Army Combat, rear hip pocket

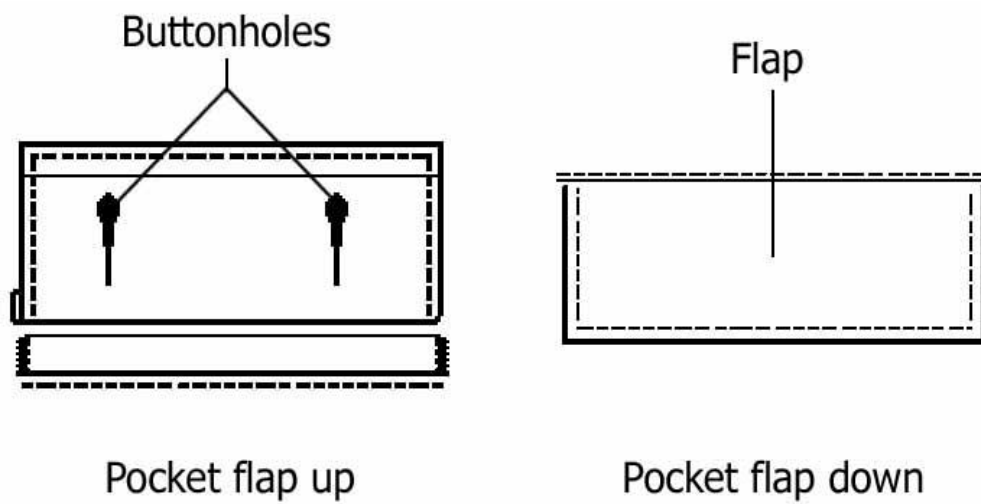
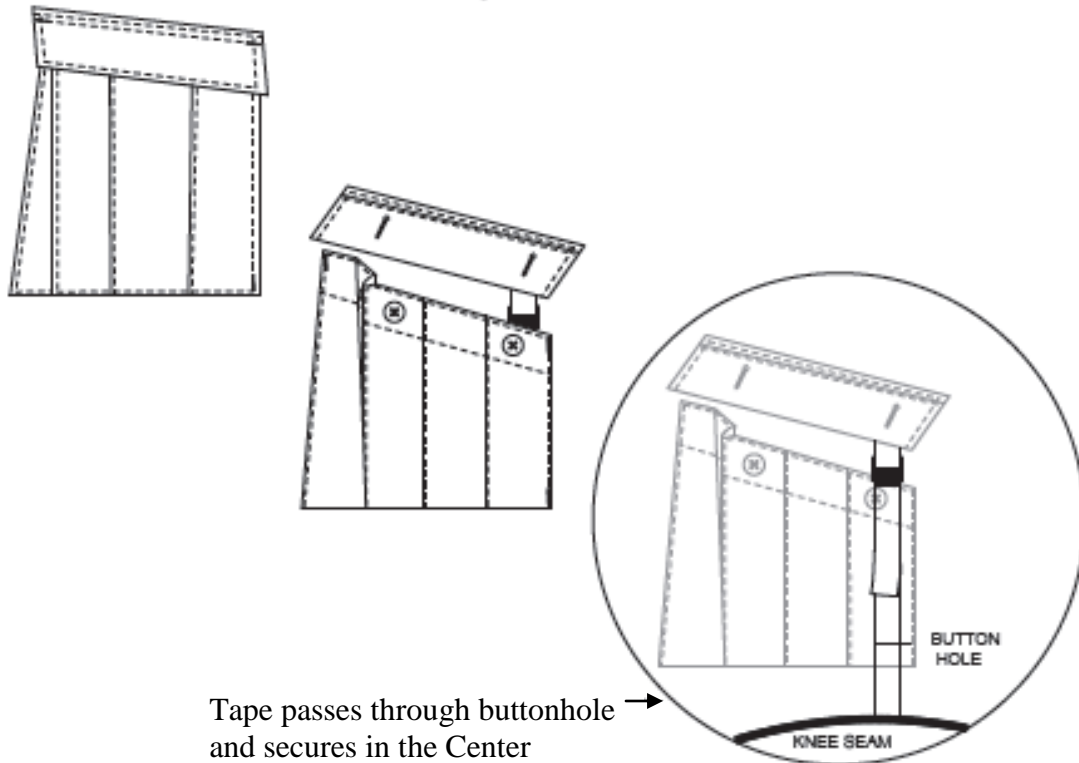

FIGURE 4. Pant, Army Combat, cargo pocket



Tape passes through buttonhole and secures in the Center

FIGURE 5. Pant, Army Combat, lower leg pocket

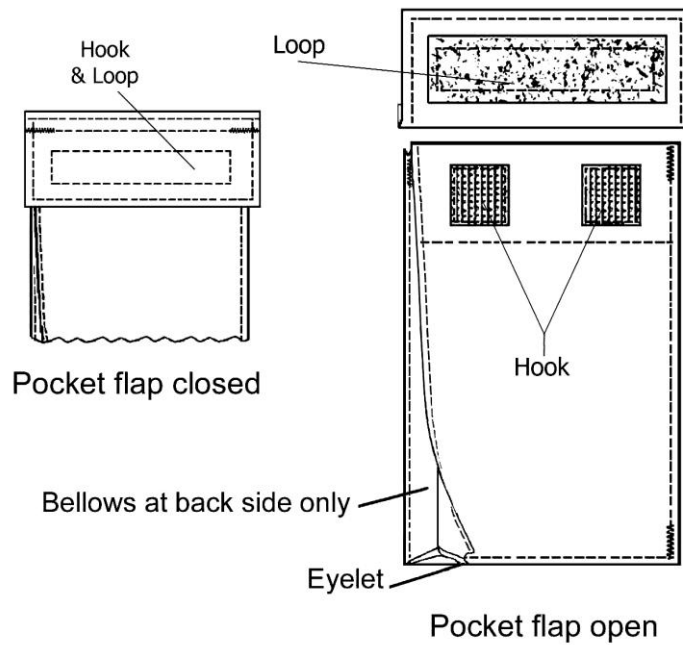

FIGURE 6. Pant, Army Combat, fly detail

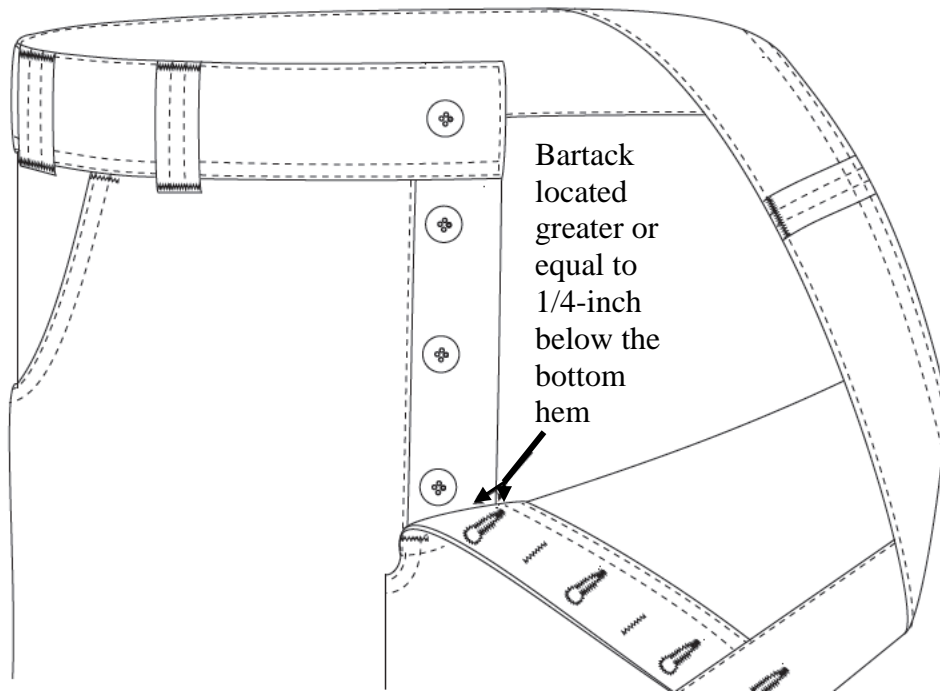
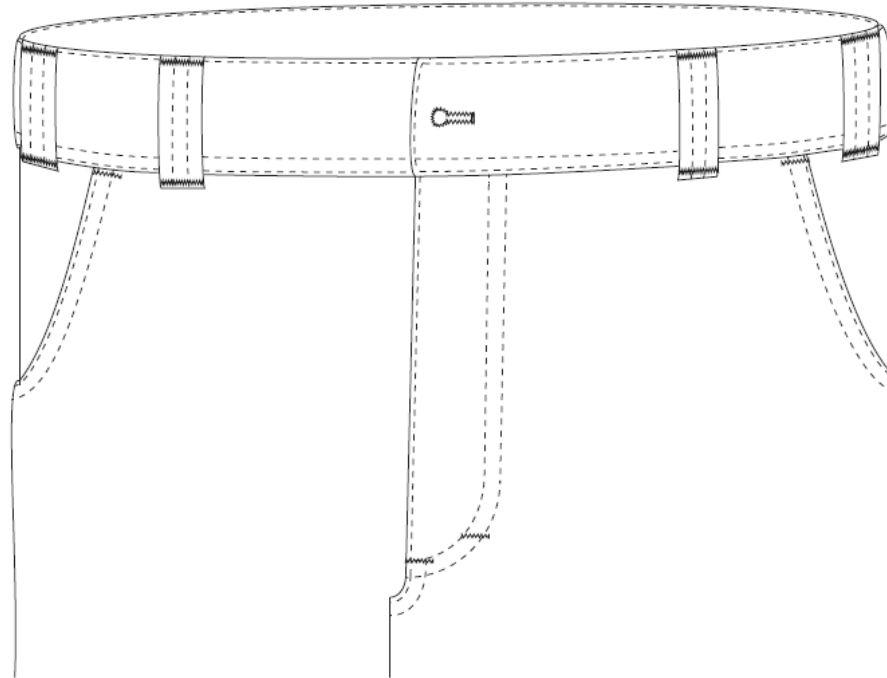
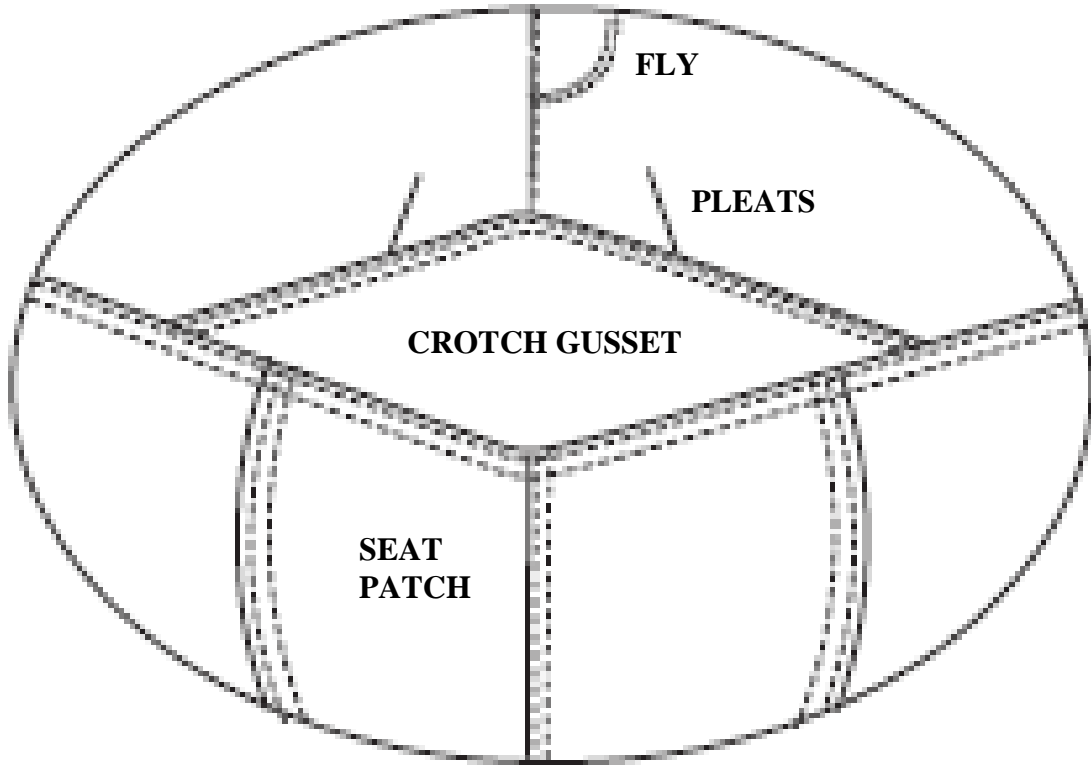

FIGURE 7. Pant, Army Combat, crotch gusset



CUSTODIAN:
Army – GL

PREPARING ACTIVITY:
DLA – CT