

07 JULY 2009

**PURCHASE DESCRIPTION
BODY ARMOR, MULTIPLE THREAT
PLATE CARRIER**

1. SCOPE

1.1 Description. This purchase description provides for a multiple threat body armor system consisting of a base vest and modular components for tailoring protection levels to defeat multiple ballistic hazards across the battlefield continuum and manage armor weight. The PLATE CARRIER is a critical safety item. This specification delineates system, subsystem, component, and subcomponent level performance requirements to accomplish the end item body armor performance (see paragraph 6.1). Body armor, multiple threat is functionally integrated with Modular Lightweight Load Equipment (MOLLE).

1.2 Classification. PLATE CARRIER components; base vest, cummerbund, side plate pockets, and small arms protective inserts (SAPI, ISAPI, ESAPI, XSAPI, Side-ESAPI). The PLATE CARRIER shall be of a single type in two classes; Type 1 – Solid Coyote 498, Type 2 – Universal Camouflage. The PLATE CARRIER will be issued separately as three subsystems, as follows.

Beneficial comments (recommendations, additions, deletions) and any pertinent data which may be used in improving this document should be addressed to: John Kirejczyk, (508) 233-4348, DSN 256-4348, John.Kirejczyk@us.army.mil , US Army Natick Soldier RDEC Kansas Street, Natick, MA 01760
--

- A) The PLATE CARRIER subsystem; consisting of the base vest assembly, cummerbund assembly, and two side plate pockets.

COMPONENT	SIZES
Base Vest Assembly	5 sizes; X-Small, Small, medium, Large, X-Large
Cummerbund Assembly	3 sizes; X-Small-Small, Medium, Large-X-Large
Side Plate Pockets	One size; one set

- B) The SAPI subsystem; consisting of a set of SAPI, ISAPI, ESAPI and XSAPI in the same size as the PLATE CARRIER.

COMPONENT	SIZES
Small Arms Protective Insert (SAPI, ISAPI, ESAPI, XSAPI)	5 sizes: X-Small, Small, Medium, Large, X-Large

- C) The Enhanced Side Small Arms Protective Insert (E-SSAPI) or Enhance Side Ballistic Insert (ESBI) subsystem; consisting of a set of E-SSAPI or ESBI in one standard size or a set of X-Small ESAPI.

COMPONENT	SIZES
Enhanced Side SAPI (E-SSAPI)	One size
Enhanced Side Ballistic Insert (ESBI)	One size

2. APPLICABLE DOCUMENTS

2.1 General. The documents listed in this section are specified in sections 3 and 4 of this performance requirement. This section does not include documents cited in other sections of this specification or recommended for additional information or as examples. While every effort has been made to ensure the completeness of this list, document users are cautioned that they must meet all specified requirements documents cited in sections 3 and 4 of this specification, whether or not they are listed.

2.2 Government documents.

2.2.1 Specifications, standards, and handbooks. The following specifications, standards, and handbooks form a part of this document to the extent specified herein. Unless otherwise specified, the issues of these documents are those listed in the issue of the Department of Defense Index of Specifications and Standards (DoDISS) and supplement thereto, cited in the Solicitation (see paragraph 6.2).

SPECIFICATIONS DEPARTMENT OF DEFENSE

MIL-DTL-32075	- Label: For Clothing, Equipage, and Tentage (General Use).
MIL-PRF-5038	- Tape, Textile and Webbing, Textile, Reinforcing Nylon

MIL-PRF-63460	- Lubricant, Cleaner and Preservative for Weapons and Weapons Systems (Metric)
CO/PD 00-03	- Small Arms Protective Inserts (SAPI)
CO/PD 05-02	- Improved, Small Arms Protective Inserts (ISAPI)
CO/PD 04-19	- Enhanced, Small Arms Protective Inserts (ESAPI)
FQ/PD 07-03	- X Small Arms Protective Inserts (XSAPI)
CO/PD 06-20	- Enhanced Side Ballistic Insert (ESBI)
A-A-55301	- Webbing, Textile Textured or Multi-Filament
A-A-55126	- Fastener Tape, Hook and Pile, Synthetic
MIL-W-4088	- Webbing, Textile Woven Nylon
MIL-C-43734	- Cloth, Duck, Textured Nylon
MIL-STD-662F	- V50 Ballistic Test for Armor
MIL-STD-3027	- Performance Requirements and Testing of Body Armor
MIL-DTL-46593B	- PROJECTILE, CALIBERS .22, .30, .50, AND 20 mm FRAGMENT-SIMULATING
MIL-W-17337	- Webbing, Textile, Woven Nylon
A-A-59826	- Thread, Nylon
MIL-STD-810	- Environmental Engineering Considerations and Laboratory Tests
MIL-C-7020	- Cloth, Parachute, Nylon Rip-Stop and Twill Weave
MIL-E-20652	- Eyelets, Metallic, Rolled Flange Type; and Eyelet Washer
MIL-F-10884	- Fasteners, Snap
MIL-W-5664	- Webbing, Textile Elastic

(Unless otherwise indicated, copies of the above specifications, standards, and handbooks are available from the Standardization Document Order Desk, 700 Robbins Avenue, Building 4D, Philadelphia, PA 19111-5094 or www.dsp.dla.mil using Assist Quick Search).

2.2.2 Other Government documents, drawings, and publications. The following other Government documents, drawings, and publications form a part of this document to the extent specified herein. Unless otherwise specified, the issues are those cited in the solicitation.

DRAWINGS

Project Manager – Soldier Equipment, Program Executive Office – Soldier, Fort Belvoir, VA
 Drawing No. 2-1-2519 Universal Camouflage Pattern 60 inches
 Drawing No. 2-1-2519-1 Universal Camouflage Desert Sand 500
 Drawing No. 2-1-2519-2 Universal Camouflage Urban Gray 501
 Drawing No. 2-1-2519-3 Universal Camouflage Foliage Green 502

MANUALS

TM 10-8400-203-23 General Repair Procedures for Individual Equipment; Chapter 25, Maintenance of Interceptor Body Armor System
 GSA Federal Standardization Manual 2000

TEST OPERATING PROCEDURES

USATECOM ITOP 4-2-805 Projectile Velocity and Time of Flight Measurements

Requests for above may be addressed to Defense Technical Information Center (DTIC), 8725 John J. Kingman Road, Suite 0944, Ft. Belvoir, VA 22060-6218, (703) 767-8274, <http://stinet.dtic.mil/>, or msorders@dtic.mil

(Copies of drawings, publications, and other Government documents required by contractors in connection with specific acquisition functions should be obtained from the contracting activity or as directed by the contracting activity.)

2.3 Non-government publications. The following documents forms a part of this document to the extent specified herein. Unless otherwise specified, the issues of the documents which are Department of Defense adopted are those listed in the issue of the DoDISS cited in the solicitation. Unless otherwise specified, the issues of documents not listed in the DoDISS are the issues of the documents cited in the solicitation (see paragraph 6.2).

AMERICAN ASSOCIATION OF TEXTILE CHEMISTS AND COLORISTS (AATCC)

AATCC METHOD 8	- Colorfastness to Crocking; AATCC Crockmeter Method
AATCC METHOD 15	- Colorfastness to Perspiration
AATCC METHOD 16	- Colorfastness to Light
AATCC METHOD 22	- Water Repellency; Spray Test
AATCC METHOD 61	- Colorfastness to Laundering, Home and Commercial: Accelerated
AATCC METHOD 70	- Water Repellency: Tumble Jar Dynamic Absorption Test
AATCC METHOD 96	- Dimensional Changes in Commercial Laundering of Woven and Knitted Fabrics Except Wool
AATCC METHOD 118	- Oil Repellency: Hydrocarbon Resistance Test
AATCC METHOD 119	- Color Change Due to Flat Abrasion (Frosting): Screen Wire Method
AATCC METHOD 127	- Water Resistance: Hydrostatic Pressure Test
AATCC Procedure 1	- Gray Scale for Color Change
AATCC Procedure 2	- Gray Scale for Staining

(Applications for copies should be addressed to the American Association of Textile Chemists and Colorists, PO Box 12215, Research Triangle Park, NC 27709-2215 or www.aatcc.org).

AMERICAN SOCIETY FOR TESTING AND MATERIALS (ASTM)

ASTM D-204	- Sewing Threads
ASTM D-1388	- Stiffness of Fabrics
ASTM D 1424	- Tearing Strength of Woven Fabrics by Falling-Pendulum Type (Elmendorf) Apparatus
ASTM D-1683	- Failure in Sewn Seams of Woven Fabrics
ASTM D-1693	- Standard Practice for Stitches and Seams
ASTM D-1777	- Standard Method for Testing Thickness of Textile Materials
ASTM D-3575	- Materials, Flexible Cellular, Made From Olefin Polymers
ASTM D-3776	- Mass Per Unit Area (Weight) of Woven Fabric

ASTM D-3884	- Abrasion Resistance of Textile Fabrics, (Rotary Platform, Double Head Method)
ASTM D-3886	- Abrasion Resistance of Textile Fabrics, (Inflated Diaphragm)
ASTM D-4485	- Standard Specification for Performance of Engine Oils
ASTM D-5034	- Breaking Force and Elongation of Textile Fabrics (Grab Test)
ASTM D-6193	- Standard Practice for Stitches & Seam
ASTM G21-90	- Test Methods for Evaluation of Effect of Fungi on Synthetic Polymeric Materials

(Applications for copies should be addressed to ASTM International, 100 Barr Harbor Drive, PO Box C700, West Conshohocken, PA 19428-2959 or www.astm.org)

AMERICAN NATIONAL STANDARDS INSTITUTE (ANSI)

ANSI/ASQ Z1.4-2003 - Sampling Procedures and Tables for Inspection by Attributes

INTERNATIONAL ORGANIZATION FOR STANDARDIZATION (ISO)

International Standard 11092: 1993 - Measurement of thermal and water vapor resistance under steady state conditions

(Applications for copies should be addressed to the American National Standards Institute, 25 West 43rd Street, 4th Fl., New York, New York, 10036, Tel: (212)642-4900, Fax: (212)398-0023, <http://www.ansi.org>).

2.4 Order of precedence. In the event of a conflict between the text of this document and the references cited herein, the text of this document takes precedence. Nothing in this document, however, supersedes applicable laws and regulations unless a specific exemption has been obtained.

3. REQUIREMENTS

3.1 First Article Test and Lot Acceptance Test. When specified, complete Body armor, multiple threat samples, representing full production quality, shall be subjected to First Article Testing in accordance with 4.2 or Lot Acceptance Testing in accordance with 4.3.

3.2 Materials and Components. The materials and components shall conform to applicable specifications, standards, and patterns required herein.

3.2.1 Cloth Outer and Inner Shell. The cloth(s) utilized to fabricate the outer shell and inner shell shall be made from lightweight, durable, synthetic cloths meeting the characteristics outlined in Appendix A, Table I when tested as specified in 4.5 (Appendix C, Table I). Color: Type 1 – Coyote 498, Type 2 - Universal Camouflage and Foliage Green 504.

3.2.1.1 Weight of Finished Fabric: The weight of the finished outer shell fabric shall be no greater than 12.0 oz/sqyd. The weight of the finished middle and inner shell fabric shall be no greater than 8.0 oz/sqyd.

3.2.1.2 Pattern Execution, Outer Shell, Universal Camouflage: Type 2 - The pattern on the printed finished cloth shall be reproducible to the standard sample in respect to design, colors and registration of the respective areas. The pattern repeat shall be 36.00 (+1.25, -2.50) inches in the warp direction. The various areas of the pattern shall be properly registered in relation to each other and shall present definite sharp demarcations with a minimum of feathering or spew. Each pattern area shall show solid coverage; skitteriness exceeding that shown on the standard sample in any of the printed areas will not be acceptable. When the standard sample is not referenced for pattern execution, a pattern drawing shall be provided and the pattern shall match Drawing 2-1-2519.

3.2.2 Cloth Ballistic Panel Cover. Ballistic panel cover should be 70 Denier 1.9 oz. Nylon Ripstop. Color: Type I - Tan 380; Type II - Foliage Green 504.

3.2.3 Webbing and Tapes. Webbing and tapes shall be heat cut smooth with no burrs or residual melt. Webbing and tapes shall conform to the following requirements.

- a) 1.0 inch Webbing; A-A-55301, Type III, except that the spectral reflectance requirements shall be in accordance with paragraph 3.4.6 (Appendix A, for Type 1 Table IV-A and Type 2 Table IV-B) when tested in accordance with paragraph 4.5.9. Color: Type 1 – Coyote 498, Type 2 - Universal Camouflage, Foliage Green
- b) 1.5 inch Webbing; A-A-55301, Type VI, except that the spectral reflectance requirements shall be in accordance with paragraph 3.4.6 (Appendix A, for Type 1 Table IV-A and Type 2 Table IV-C) when tested in accordance with paragraph 4.5.9. Producer colored, textured yarns may be used. When used, thickness shall be .039 in. (min); weight shall be .90 oz/yd (min). Color: Type 1 – Coyote 498, Type 2 - Foliage Green 504
- c) 2.0 inch Webbing; MIL-W-17337, except that the spectral reflectance requirements shall be in accordance with paragraph 3.4.6 (Appendix A, for Type 1 Table IV-A and Type 2 Table IV-C) when tested in accordance with paragraph 4.5.9. Producer colored, textured yarns may be used. When used, continuous filament textured nylon yarn denier shall be 1000 warp and 500 fill; breaking strength shall be 1450 lb (min); thickness shall be .042 in. (min) to .054 in. (max); filling yarns per inch shall be 40; full warp ends shall be 160; and width binder ends shall be 38. Color: Type 1 – Coyote 498, Type 2 - Foliage Green 504.
- d) 3.0 inch Webbing; MIL-W-17337 Class 2, continuous filament textured nylon shall be used. Color: Type 1 – Coyote 498, Type 2 - Foliage Green 504.
- e) 1.0 inch Tape; MIL-PRF-5038, Type III, class 2, continuous filament textured yarns shall be used except that the spectral reflectance requirements shall be in accordance with paragraph 3.4.6 (Appendix A, Table IV) when tested in accordance with paragraph 4.5.9. Color: Coyote 498. Type 2 – Foliage Green 504

3.2.3.1 Pattern Execution, Webbing. Type 2– The pattern of the finished Universal Camouflage pattern webbing shall reproduce the standard sample with respect to design, colors, and registration of the respective areas. The pattern of the webbing shall match the pattern on the specified drawing for the Universal Camouflage, 2-1-1516, 2-1-2240, and 2-1-2519.

3.2.3.2 Shade Execution, Webbing. Type 2 - The shade of each individual color shall match the colors outlined in the Universal Camouflage standard for the Duck Cloth, Textured Nylon, Universal Pattern, MIL-C-43734 Type III Class 3.

3.2.3.3 Matching, Webbing.

Type 1 PLATE CARRIER - The color of the webbing shall match the solid Coyote 498 shade PLATE CARRIER outer shell standard sample when viewed under filtered tungsten lamp which approximates artificial daylight having a correlated color temperature of 7500+/- 200K, with illumination of 100 +/- 20 foot candles, and shall be a good match to the standard sample under incandescent lamplight at 2300 +/- 200 K.

Type 2 PLATE CARRIER - The color of the webbing shall match the Universal Camouflage PLATE CARRIER outer shell standard sample when viewed under filtered tungsten lamp which approximates artificial daylight having a correlated color temperature of 7500+/- 200K, with illumination of 100 +/- 20 foot candles, and shall be a good match to the standard sample under incandescent lamplight at 2300 +/- 200 K.

3.2.4 Elastic. Elastic shall be heat cut smooth with no burrs or residual melt. Elastic shall conform to the following requirements.

- a) 1.5 inch; width – 1.5 inch \pm .0625, warp – textured polyester 150/2, filler – textured polyester 150/1, rubber – natural rubber, thickness - .060-.095, stretch – 100% \pm 10%. Color: Type 1 - Coyote 498, Type 2 - Foliage Green 504.
- b) 3 inch; width – 3 inch \pm .060, construction – knitted, warp – textured polyester 150/1, filler – textured polyester 750d total, rubber – natural or equivalent, rubber strands – 60, thickness - .040-.045, picks per inch – 50 \pm 4, stretch – 110% \pm 15%. Color: Black.

3.2.5 Fasteners, Hook, and Loop. Hook and loop fasteners shall conform to A-A-55126, Type II, Class 1, in 1.0”, 1.5”, 2.0”, and 4.0" widths. Color: Type 1 - Coyote 498, Type 2 - Foliage Green 504.

3.2.6 Foam. The foam (located within the front and back base vest and side plate pockets) shall be closed cell with the properties specified in Appendix A, Table II when tested as specified in ASTM D-3575. The foam shall be sandwiched between the last layer of ballistic filler and back of the cloth inner shell and two layers of foam shall be sewn into the back flap.

3.2.7 Polyethylene. 0.030 \pm 0.005 inches thick, high density per paragraph 3.3.1.3 Item 15 and paragraph 3.3.1.10. 0.045 \pm 0.005 inches thick, high density per paragraph 3.3.1.3 Item 16. Color: Natural.

3.2.8 Cable. 3/32 Galvanized 7x7 aircraft cable coated to 5/32 +.006/-.0 with natural nylon or 3/32 Galvanized 7x7 aircraft cable coated to .165 +/- .006 with natural nylon. Ends of cable shall have no exposed metal.

3.2.9 Cable Sleeves. 5/32 copper sleeves.

3.2.10 Thread. Thread, Nylon, Bonded, Size F, A-A-59826, Type II, Class A. Color: Type 1 – Coyote 498, Type 2 - Foliage Green 504.

3.2.11 Buckle Side Release. 1 ½ inch SR SPLIT BAR, acetal, ITW P/N 101-3150-xxxx, or 1 ½ inch Mojave Male, acetal, P/N 4494 and 1 ½ inch Mojave Repairable Female, acetal, P/N 9276 or equal. Color: Type 1 – Coyote 498, Type 2 - Foliage Green 504. Spectral reflectance requirements shall be in accordance with paragraph 3.4.6 (Appendix A, Type 1 - Table IV-A, Type 2 - Table IV-E) when tested in accordance with paragraph 4.5.9.

3.2.12 Tension Lock. Trovato Ladderloc TLL 150 acetal P/N 154-0150-xxxx, or equal. Color: Type 1 – Coyote 498, Type 2 - Foliage Green 504. Spectral reflectance requirements shall be in accordance with paragraph 3.4.6 (Appendix A, Type 1 - Table IV-A, Type 2 - Table IV-E) when tested in accordance with paragraph 4.5.9. A self threading (i.e. repairable) Ladderloc shall be included in repair kits as specified in the contract.

3.2.13 Loop. 1 inch, Looploc, acetal, ITW P/N 111-0100-xxxx, or equal Color: Type 1 – Coyote 498, Type 2 - Foliage Green 504.

3.2.14 Loop. 1 ½ inch Steel or brass, Welded. ITW P/N 01041-20-2188x, or equal Color: Type 1 – Coyote 498, Type 2 - Foliage Green 504

3.2.15 Loop. 1 ½ inch, Looploc, acetal, ITW P/N 111-0150-xxxx, or equal Color: Type 1 – Coyote 498, Type 2 - Foliage Green 504

3.2.16 Grommet. Plain, brass, black oxide, NASM16491, size 0, type I, class 3

3.2.17 Washer. Plain, brass, black oxide, NASM16491, size 0, type I, class 3

3.2.18 Quick Release Handle Cover. Polyvinyl chloride tubing. OD 0.380 +/- 0.005 inches, ID 0.250 +/- 0.005 inches Color: Type 1 - Tan 499, Type 2 – Foliage Green 504.

3.2.19 Cord. Dacron cord poly-braided FED SPEC.#T-C-2754-I Dacron ¼”, Tensile strength 250 lbs. Color: White

3.3 Design. The Body armor, multiple threat model dismounted system is a modular vest protecting the upper torso from multiple ballistic threats which is easily configured to defeat predicted mission threat at a minimum system weight. The PLATE CARRIER subsystem (see 3.5) consists of (1) One base vest assembly made up of a outer shell base vest carrier with non-removable ballistic insert set (back and front) and one set of shoulder straps, (2) One

cummerbund assembly made up of two interchangeable sides, two interchangeable cummerbund adapters and one emergency release cable (3) One set of side plate pockets with non-removable ballistic insert. Components/assembly all interface with the PLATE CARRIER. The PLATE CARRIER provides protection from conventional fragmenting munitions and multiple hits from 9mm handgun rounds. The SAPI, ISAPI, ESAPI or XSAPI subsystem consists of a set of interchangeable, sized, and contoured plates inserted into front and back pockets inside the PLATE CARRIER to provide vital organs protection against multi-hits of small arms rifle bullets and indirect fire flechettes. The Enhanced Side SAPI and Enhanced Side Ballistic Insert subsystem consists of a set of interchangeable, contoured plates inserted into the side plate pockets worn inside the cummerbund. Webbing hanger attachments on the front of the PLATE CARRIER outershell accommodate limited load carrying compatible with MOLLE modular load bearing vest pockets. The variants of Body armor, multiple threat modular system configurations follow below. Recommended enhancements are encouraged to improve its operational effectiveness and manufacturability.

- a) PLATE CARRIER base vest only; which does not include any of the cummerbund assembly or SAPI, ISAPI, ESAPI or XSAPI modular components.
- b) PLATE CARRIER base vest with cummerbund assembly with or without side plate pouches and/or one or two SAPI, ISAPI, ESAPI, or XSAPI and/or two Enhanced Side SAPI or Enhanced Side Ballistic Inserts.

3.3.1 Patterns. The Government shall furnish patterns for the baseline design from which the contractor can use applicable parts to create cutting working patterns. Compliance with patterns is required to meet interface requirements with fielded personnel combat equipment. The working patterns shall include the size, directional lines, placement marks, notches, and provided seam allowances. Baseline patterns require a 3/8" seam allowance +/-1/16" unless otherwise stated on patterns. Except for the ballistic panels, all the components of the vest shall be cut with a tolerance of +/- 1/16" in accordance with the pattern parts indicated except where changes or enhancement(s) to baseline are proposed. The ballistic panels shall be cut with a tolerance of -1/16"/+1/8" to ensure maximum protective area of coverage is achieved (see paragraph 3.5, Appendix A, Table V-A). Drill holes are not permitted.

3.3.1.1 Base PLATE CARRIER and Components Carrier Outer Shell

Item	Nomenclature	Computer Nomenclature	Cut
1	FRONT OUTER SHELL	PLATE-FRONT OUT SHLL	1
2	FRONT OUTER UPPER SHELL	PLATE-FRT OUT UP SHL	1
3	FRONT LOWER FLAP	PLATE-FRONT LOW FLAP	1
4	BACK OUTER SHELL	PLATE-BACK OTR SHLL	1
5	BACK UPPER FLAP	PLATE-BACK UPPR FLAP	1
6	BACK LOWER FLAP	PLATE-BACK LOWR FLAP	1
7	BACK SHOULDER HOLDER	PLATE-BACK SHLDR HLD	2

3.3.1.2 Base PLATE CARRIER and Components Carrier Inner Shell

Item	Nomenclature	Computer Nomenclature	Cut
8	FRONT INNER SHELL	PLATE-FRONT INN SHLL	1

9	FRONT MIDDLE SHELL	PLATE-FRNT MID SHLL	1
10	BACK INNER SHELL	PLATE-BACK INN SHLL	1
11	BACK MIDDLE SHELL	PLATE-BACK MID SHELL	1
12	PLATE SLEEVE	PLATE-PLATE SLEEVE	2
13	LOOP NAME TAPE REINFORCEMENT	PLATE-NAME TAPE RNFC	1
14	BACK TUNNEL FACING	PLATE-TUNNEL FACING	2

3.3.1.3 Base PLATE CARRIER and Components Plastic.

Item	Nomenclature	Computer Nomenclature	Cut
15	FRONT FLAP PLASTIC	PLATE-FRT PLSTC FLAP	1
16	SHOULDER STRAP PLASTIC	PLATE-SHL STRP PLSTC	1

3.3.1.4 Base PLATE CARRIER and Components Ballistics.

Item	Nomenclature	Computer Nomenclature	Cut
17	FRONT BALLISTIC WIDE	PLATE-FRT BLLST WIDE	x
18	FRONT BALLISTIC NARROW	PLATE-FRT BLLST NRRW	x
19	BACK BALLISTIC WIDE	PLATE-BACK BLST WIDE	x
20	BACK BALLISTIC NARROW	PLATE-BACK BLST NRRW	x

3.3.1.5 Base PLATE CARRIER and Components Foam.

Item	Nomenclature	Computer Nomenclature	Cut
21	FRONT FOAM	PLATE-FRONT FOAM	1
22	BACK FLAP FOAM	PLATE-BACK FLAP FOAM	2
23	BACK FOAM	PLATE-BACK FOAM	1

3.3.1.6 Base PLATE CARRIER and Components 3" Webbing

Item	Nomenclature	Computer Nomenclature	Cut
24	PLATE STRAP	PLATE-PLATE INN STRP	1

3.3.1.7 Base PLATE CARRIER and Components 1.5" Webbing

Item	Nomenclature	Computer Nomenclature	Cut
25	SHOULDER STRAP BUCKLE	PLATE-SHOULDER STRAP	2
26	SHOULDER STRAP YIBYAB	PLATE-SHLD STRP YBYB	1
27	SIDE FEMALE BUCKLE	PLATE-SID FEML BUCKL	2
28	FRONT SHOULDR BUCKLE	PLATE-FRT SHLD BUCKL	2
29	BACK WAIST CENTER	PLATE-BACK WST CNTR	1
30	BACK WAIST SIDE	PLATE-BACK WST SIDE	2
31	BACK SHOULDER BUCKLE	PLATE-BACK SHLD BCKL	2

3.3.1.8 Base PLATE CARRIER and Components 1" Webbing

Item	Nomenclature	Computer Nomenclature	Cut
32	YIBYAB TEMPLATE	PLATE-YIBYAB TEMPLAT	1
33	FRONT POCKET PULL TAB	PLATE-FRNT PCKT PULL	1
34	PACK ATTACHMENT	PLATE-PACK ATTACHMNT	2
35	FRONT FLAP HANDLE	PLATE-FRNT FLP HANDL	1

3.3.1.9 Cummerbund and Components Shell

Item	Nomenclature	Computer Nomenclature	Cut
1	OUTER SHELL	CUMMERBUND-OUTR SHLL	1
2	INNER SHELL	CUMMERBUND-INNR SHLL	1

3.3.1.10 Cummerbund and Components Plastic

Item	Nomenclature	Computer Nomenclature	Cut
3	CUMMERBUND PLASTIC	CUMMERBUND-PLASTIC	2
4	WAIST ADAPTOR PLASTIC	CUMMERBUND-ADAPTOR	2

3.3.1.11 Cummerbund and Components 3" Webbing

Item	Nomenclature	Computer Nomenclature	Cut
5	SIDE ADJUSTMENT STRAP	CUMMERBUND-ADJ STRAP	2

3.3.1.12 Side Plate Pocket and Components Shell

Item	Nomenclature	Computer Nomenclature	Cut
1	FRONT LOWER	SDPLATE-FRONT LOWER	1
2	FRONT UPPER	SDPLATE-FRT UPPER	1
3	BACK	SDPLATE-BACK	1

3.3.1.13 Side Plate Pocket Ballistic Panel

Item	Nomenclature	Computer Nomenclature	Cut
4	BALLISTIC INSERT	SDPLATE-BALLISTIC	

3.3.1.14 Side Plate Pocket Ballistic Panel Cover

Item	Nomenclature	Computer Nomenclature	Cut
5	MIDDLE LINING	SDPLATE-MIDDLE LINNG	1

3.3.1.15 Side Plate Pocket Foam

Item	Nomenclature	Computer Nomenclature	Cut
6	FOAM	SDPLATE-FOAM	1

3.3.1.16 Side Plate Pocket 3" Elastic

Item	Nomenclature	Computer Nomenclature	Cut
7	ELASTIC HOLDER	SDPLATE-ELASTIC	1

3.3.1.17 Templates.

Item	Nomenclature
1	QUICK RELEASE PULL CABLE
2	SHOULDER STRAP
3	YIB-YAB SHOULDER STRAP
4	SIDE STRAP
5	CUMMERBUND ADAPTER

3.3.1.18 Fastener Tape, Hook and Loop, A-A-55126.

Item	Nomenclature	Cut
1	1" HOOK	PIECES ARE PER PATTERN MARKING
2	1 1/2" HOOK	PIECES ARE PER PATTERN MARKING

3	2" HOOK	PIECES ARE PER PATTERN MARKING
4	4" HOOK	PIECES ARE PER PATTERN MARKING
5	1" LOOP	PIECES ARE PER PATTERN MARKING
6	1 1/2" LOOP	PIECES ARE PER PATTERN MARKING
7	2" LOOP	PIECES ARE PER PATTERN MARKING
8	4" LOOP	PIECES ARE PER PATTERN MARKING

3.4 Multiple Threat Body Armor System Performance Requirements. The following requirements apply to all components and subcomponents of the multiple threat body armor system in any of its potential configurations in accordance with paragraph 3.3.

3.4.1 Functional Integration. All PLATE CARRIER components shall be integrated for functional and physical interfaces for any PLATE CARRIER system configuration. All components within a size shall be fully interchangeable with every other system of the same size with no degradation of performance. Any configuration of PLATE CARRIER in accordance with paragraph 3.3 shall be functionally integrated with any configuration of MOLLE (see 4.4).

3.4.2 Fungus Resistance. All components and parts of the body armor, including interior components, shall be resistant to fungal growth. The visual grading shall be less than 2. All components shall show only trace or no susceptibility to fungal growth nor experience damage due to the presence of fungus spores or adjacent fungus growth. (see paragraph 4.5.8)

3.4.3 Use and Care Instruction. An instruction pamphlet will be furnished with each body armor system. The instruction pamphlet will be printed on a durable man made, synthetic paper capable of multiple time use under harsh field conditions.

3.4.4 Camouflage. Appendix A Table III outlines the camouflage for multi terrain environment; disruptive patterns and solids, for applicable components to reduce visual and infrared (both near and far IR) signature to an acceptable level (see 4.5.9).

3.4.5 Infrared Reflectance. The infrared reflectance for finished components and subcomponents specified in 3.4.4 shall conform to the requirements specified in Appendix A, For Type 1 Table IV-A and Type 2 Tables IV-B & C initially and after laundering when tested as specified in 4.5.9. Acetal hardware shall conform to infrared reflectance requirements in Appendix A, for Type 1 Table IV-A and Type 2 Table IV-E.

3.4.6 Matching. The cloths shall match the standard (see 4.5.13).

3.4.7 Pattern Execution. Type 2 - The pattern of the finished Universal Camouflage pattern cloth shall reproduce the standard sample with respect to design, colors, and registration of the respective areas. The pattern repeat of the universal pattern shall be 36.00" +1.25/-2.50", when tested as specified in 4.1. Solid shades shall demonstrate level dyeing uniformity. The pattern of the cloth shall match the pattern on the specified drawing for universal camouflage.

3.4.8 Colorfastness. The finished cloth shall show fastness to laundering (after 3 cycles), light (after 40 standard fading hours or 170 kilojoules), and perspiration equal to or better than the standard sample or 3-4 of the AATCC Gray Scale for Color Change and Color Transfer for each

of the pattern areas, except fastness to light shall be equal to or better than a rating of 3 for Color Change. The finished cloth shall show fastness to crocking equal to or better than the standard sample or shall have an AATCC Chromatic Transference Scale rating of not lower than 3-4 for all the pattern areas. The finished textile components shall meet the colorfastness requirements when tested as specified in paragraph 4.5 (Appendix C, Table I).

3.5 PLATE CARRIER subsystem. See paragraph 3.3 for PLATE CARRIER configuration. The minimum area of ballistic coverage for each ballistic panel subcomponent in each size is outlined in Appendix A, Table V-A when tested as specified in 4.5.5. Finished base vest measurements for each size are outlined in Appendix A, Table V-C & D when inspected as specified in 4.5.2.

3.5.1 Ballistic Protection Levels. The PLATE CARRIER protection levels are as follows (see 4.1, 4.4, & 4.6):

- a) PLATE CARRIER provides fragmentation protection from conventional fragmenting munitions (see paragraph 3.5.2.2).
- b) PLATE CARRIER provides multi-hit handgun bullet protection for 9mm, 124 gr., Full Metal Jacket (FMJ) Remington projectile (see paragraph 3.5.2.3).
- c) PLATE CARRIER and SAPI (see 3.7) together provide multi-hit small arms bullet protection from:
 - (1) NATO 7.62 x 51 mm M80, Ball
 - (2) Soviet 7.62 x 54R mm Type LPS, Ball
 - (3) U.S. 5.56 x 45 mm M855, Ball
- d) PLATE CARRIER and ISAPI (3.7) together provide multi-hit small arms bullet protection from:
 - (1) NATO 7.62 x 51 mm M80, Ball
 - (2) Soviet 7.62 x 54R mm Type LPS, Ball
 - (3) U.S. 5.56 x 45 mm M855, Ball
 - (4) 7.62 x 39 mm API (Russian BZ and Chinese Type 56)
- e) PLATE CARRIER and ESAPI (3.7) together provide multi-hit small arms bullet protection from:
 - (1) NATO 7.62 x 51 mm M80, Ball
 - (2) Soviet 7.62 x 54R mm Type LPS, Ball
 - (3) U.S. 5.56 x 45 mm M855, Ball
 - (4) 7.62 x 63 mm M2, AP
- f) PLATE CARRIER and XSAPI - classified

3.5.2 Ballistic Performance. The PLATE CARRIER ballistic material system shall accomplish the ballistic characteristics specified in paragraphs 3.5.2.2, and 3.5.2.3 as tested in paragraph 4.6.

3.5.2.1 Non-Removable Ballistic Panel Subcomponent. The gap/ease between outershell carrier and panel shall be no greater than the ease allowed within the baseline patterns (see 4.5.1).

3.5.2.1.1 Ballistic filler. The sample mean ballistic filler weight shall not exceed 1.10 lb / sq. ft. with a maximum 0.30 inch thickness when tested as specified in 4.5.6 and 4.5.7. Except for ancillary components such as thread, the ballistic filler shall be made entirely of ballistic material. If ballistic filler is non-contiguous, a minimum feathered overlap of 1" is required when fully extended during individual movements to maintain uniform ballistic protection.

3.5.2.1.2 Flexibility. The ballistic filler stiffness shall not exceed 225 cm-g when tested as specified in 4.6.6.

3.5.2.1.3 Abrasion Resistance. All adjacent layers within the ballistics material system shall demonstrate abrasion resistance against each other for a minimum of 2000 cycles when tested as specified in paragraph 4.5 (Appendix C, Table I). A rating ≥ 3 is required.

3.5.2.2 Fragmentation Protection. The ballistic material system (see 3.5.2) shall provide consistent ballistic performance for each ballistic insert, base vest front and back and side plate pockets. All Plate Carrier components and base vest (see paragraph 3.3) will be made from the same approved ballistic package. Appendix B, Table I lists the required minimum V50 values for base vest assembly and side plate pockets at specified obliquity when tested with the Fragment Simulating Projectile (FSP) and Right Circular Cylinder (RCC) dry and wet (sea water).

Appendix B, Table I specifies minimum ballistic performance that shall be maintained after conditioning to hot and cold temperature, accelerated aging and POL contamination. Testing is specified in 4.5. Any change in the PLATE CARRIER area of coverage must meet minimum casualty reduction potential of the approved system coverage (see 3.5, Appendix A, Table V-A) and V50 performance (see Appendix B, Table I) stated herein. Any product improvements in the ballistic performance of the PLATE CARRIER base vest panels and/or side plate pocket panels shall not reduce the ballistic performance of the Body armor, multiple threat system small arms protection of base vest and SAPI when tested as specified in SAPI/ISAPI/ESAPI/XSAPI performance requirements (see 2.2).

3.5.2.3 Handgun Protection. The ballistic material system shall be engineered to provide handgun protection at no added weight to the fragmentation material system. Appendix B, Table II outlines the ballistic material system minimum dry V50, and V0 acceptance for the 9mm, 124 gr., FMJ Remington projectile against 3 hits at 0 degree obliquity and 2 hits at 30 degree obliquity with maximum deformation when tested as specified in 4.6. Desired 9mm performance is required at no added material weight.

3.5.3 PLATE CARRIER Construction. The exterior of the system shall be edge stitched approximately 1/8 inch from only those edges indicated with corresponding location markings on the patterns provided. All stitching shall be back-tacked to prevent raveling and demonstrate good stitching quality with no loose ends, consistent stitches per inch, even tension with no loose needle or bobbin thread. Fabric edges shall not ravel.

3.5.3.1 Hook and Loop Fastener. Hook and loop fasteners shall not be stitched in the selvage edge to prevent associated fraying durability problems in repeated use (see 4.5).

3.5.3.2 Stitching. Stitching shall conform to ASTM D-6193, 9-10 stitches per inch. End of seams and stitches (stitch type 301) that are not caught in other seams or stitching shall be securely back tacked or back stitched. Thread breaks or bobbin run-outs occurring during sewing shall be secured by stitching back of the break minimum of 1/2 inch. Thread tension shall be maintained so that there will be no loose stitching resulting in loose bobbin or top thread, or excessively high stitching resulting in puckering of the materials sewn. Thread ends shall be trimmed to a length of not more than 1/4 inch.

3.5.3.3 Automatic Stitching. Automatic stitching machines may be used to perform any of the stitching patterns provided the requirements for the stitch pattern, stitches per inch, size and type of thread are met, and at least three or more tying, overlapping, or back stitches are used to secure the ends of the stitching.

3.5.3.4 Bartacks. No stitch run-off is allowed and no needle cutting by bartack. Double bartacks (one on top of the other) will be avoided to prevent needle cutting and weakening of the attachment point. Bartack requirements are specified in Appendix A, Table VI when tested as specified in 4.5.

3.5.3.5 Bartack Alignment for MOLLE Pocket Attachment. The required spacing of vertical bartacks is specified below which is needed for physical compatibility of MOLLE pocket attachment on PLATE CARRIER base vest.

- a) Distance between vertical bartacks on horizontal webbing shall be 1 1/2" – 0/+1/16".
- b) Distance between non-consecutive horizontal webbing shall be 1 1/8" ($\pm 1/16$).
- c) Vertical bartacks on consecutive horizontal webbing rows shall be vertically aligned with an offset of 3/4" 0/+1/16" from the bottom bartack to top of bartack on consecutive horizontal webbing.

3.5.3.6 Buttonholes. Buttonholes shall be straight cut. Position in accordance with the marks indicated on the pattern, with the ends of the buttonholes securely tacked. All buttonholes will be 1 1/4" with a finished cut of 1" +/- 1/16".

3.5.3.7 Drag Strap. The drag strap on the back of the PLATE CARRIER (all sizes) shall have a peak strength not less than 400 lbf (increased strength is desirable) when tested in accordance with para 4.8.

3.5.3.8 Release Cable. Ends of cable to be free of burrs, sharp edges and shall have no exposed metal. Cable sleeve to be crimped to disallow movement of cable. The cable will be crimped in the cable sleeve to form a loop on one side. The loop will be 1.25" tall, as measured from the edge of the sleeve. The lengths of the cables are provided in Appendix A, Table VII. The

lengths shall be measured from the end of the cable to the closest edge of the sleeve. The crimped cable sleeve shall be contained within the handle to prevent potential snag hazards.

3.5.3.9 Binding. All ends of binding not completely encased are to be seared.

3.5.3.10 Torso Adjustment. Torso adjustment shall provide the wearer a means to easily secure the vest to the torso. The external adjustment located in front of the wearer, shall be a hook and loop type closure. The external adjustment, located behind the wearer, shall utilize the cummerbund adapter and adjust using the MOLLE attachments on the outside of the cummerbund. The left and right shoulder straps shall utilize friction adjustment and hook and loop type closure.

3.5.3.11 Emergency Release Mechanism. An emergency release mechanism shall be provided. The activator shall be located on the cummerbund portion of the vest and be capable of being configured to allow operation with either hand, gloved or not. Upon activation of the mechanism, the cummerbund shall separate in the back of the vest;

3.6 Size, Identification, and Instruction Label. Labels will be readable under low light conditions; moonlight and red or blue filtered flashlight. The label shall be of sufficient strength to withstand repeated abrasion during field use and cleaning, and include the following:

- a) The PLATE CARRIER base vest back component shall have a combination size, identification, serial number, and ballistic protection level and instruction label for the base vest (APPENDIX E). Chest circumference for each size in Appendix A, Table VIII.
- b) The side plate pockets shall have a combination identification, serial number, and ballistic protection level for the side plate pocket (APPENDIX E).
- c) The cummerbund consists of 3 sizes and is comprised of two base components that are interchangeable with one another, eliminating independent left and right sides. Each cummerbund base component shall have a combination size, identification, and serial number. Waist circumference for each size in Appendix A, Table IX.
- d) The instruction label shall include do's and don'ts for use and cleaning instructions, and donning/doffing instructions for the entire PLATE CARRIER system (APPENDIX E).
- e) The instruction label shall be located on the inside of the back of the base vest (APPENDIX E). The size of the label shall be 4.5 inches wide by 7.75 inches high. The type shall be no smaller than 10 point and shall be in accordance with MIL-DTL-32075, Type VI, Class 14. Color: Type 1 – Tan, Type 2 - Foliage Green. Contents of labels shall be as found in 6.6.

3.7 SAPI Pocket. The PLATE CARRIER SAPI pockets shall ensure positioning of the bottom horizontal edge according to the Government patterns for proper organ coverage, and have enough ease to allow the SAPI, ISAPI, ESAPI, or the XSAPI to be easily and quickly

inserted into and removed from the vest without struggle or force. The SAPI pocket shall ensure that along the entire perimeter of the Insert that a minimum of 1 inch 0/+ 1/8" of ballistic filler extends beyond the edge of the corresponding size Insert for all sizes. The SAPI pocket shall not allow the Insert to shift during user operation or due to added weight of MOLLE components attached to the outershell. (see paragraph 4.7.1,4.7.2, and 4.7.3).

3.8 Responsibility for compliance. All items shall meet all requirements of section 3 and 4 of this specification. The absence of any inspection requirements shall not relieve the contractor of the responsibility of ensuring that all products of supplies submitted to the government for acceptance shall comply with all requirements of the contract. Sampling inspection, as part of manufacturing operations, is an acceptable practice to ascertain conformance to requirements; however, this does not authorize submission of known defective material, either indicated or actual, nor does it commit the government to accept defective material. If there is a conflict between the stated requirements and the ANSI standard, the more restrictive requirement shall apply.

4. VERIFICATION

4.1 Classification of Inspections. The inspection requirements specified herein are classified as outlined below. Unless otherwise specified, the contractor is responsible for the performance of all inspection requirements specified herein. The Government reserves the right to perform any of the inspections set forth where such inspections are deemed necessary to ensure the supplies conform to prescribed requirements.

a) First Article Test (see 4.2)

b) Lot Acceptance Test (see 4.3)

4.2 First Article Test. When a First Article Test is required, it shall be examined for design (3.3), compatibility and interchangeability of components, inspection requirements in 4.5, ballistic data for all test conditions 4.6.1.1, data, certificate, or compliance for testing requirements in 4.6 and 4.7, and overall workmanship (see Appendix C, Table I). The procuring activity may eliminate any test(s) when sufficient documentation already exists to verify compliance. This is encouraged in cases when additional models or minor changes from a currently approved model(s) are to be verified. In these cases, only the applicable portions of the First Article Test will be conducted.

4.2.1 Material Qualification. At any point after a First Article Test has been approved, any material change must be tested in accordance with the appropriate paragraph of this Purchase Description and approved by the government.

4.2.2 Ballistic Qualification. At any point after a First Article Test has been approved, any material or process change to the ballistic package will be required to pass all ballistic First Article Test requirements as specified in paragraph 4.6.

4.3 Lot Acceptance Test. Lot Acceptance Testing shall be performed in accordance with Section 3 and 4 in conjunction with Appendices A, B, C, and D. The Government's acceptance of the contractor's end item product will be determined by the ballistic and non-ballistic requirements validation.

4.3.1 Certificate of Compliance (COC). When certificates of compliance are required, the Government reserves the right to inspect such items to determine the validity of the certification.

4.4. Demonstration Verification. The performance requirement is verified by observation and operation that the properties, characteristics and parameters of the item meet the functional requirements specified in applicable paragraphs of Section 3. Pass or fail criteria are simple accept or reject indications of functional performance since no qualitative values exist or are difficult to measure (see Appendix C, Table I).

4.5 Requirements and Verifications. Appendix C, Table I delineates performance requirements verified through visual methods, including physical measurements in order to determine that no deficiencies exist.

4.5.1 End Item Visual Inspection. The end items shall be inspected for the defects listed in Appendix C, Table II. The lot size shall be expressed in units of base vests, base vest and cummerbund assembly or the individual components (when component is purchased separately). The sample unit shall be one completely fabricated base vest, base vest and cummerbund assembly or individual component.

4.5.2 End Item Dimensional Inspection. The end items shall be inspected for finished measurements (see Appendix C, Table III). The lot size shall be expressed in units of base vests, base vest and cummerbund assembly or the individual components (when component is purchased separately). The sample unit shall be one completely fabricated base vest, base vest and cummerbund assembly or individual component.

4.5.2.1 Linear Measurements. Front and back center measurements are taken along the center line by holding the garment taut with a metal measuring device and measurements taken to the nearest 1/16 inch. Front and back width, and webbing hanger's measurements are taken in a flat, relaxed state, with a metal measuring device and measurements taken to the nearest 1/16 inch. Cummerbund length and width measurements are taken along the horizontal and vertical line by holding the garment taut with a metal measuring device and measurements taken to the nearest 1/16 inch. Cummerbund side plate pocket channel opening measurements are taken along the outer edge of the cummerbund. Dimensional measurements are taken as described below:

- a) Spacing of Webbing Hangers for MOLLE pockets: The horizontal distance between bartacks shall be taken from the center of one bartack to the center of the adjacent bartack. The spacing between non-consecutive horizontal webbing shall be measured on adjacent webbings from the bottom edge of one to the top edge of the other.
- b) Center Front and Back Lengths: The center front and back length shall be taken on a straight line from the center of the back from the top edge of the base vest neckline

(center front and back) to the bottom edge of the shell. Note: Front flap and/or back center flap may be raised while taking measurement.

- c) Front and Back Width: The front and back width shall be taken on a straight line measuring across panel from side to side at top of webbing for waist adjustment buckle.
- d) Cummerbund Length and Width: The lengths and width shall be taken on a straight line from center edge to center edge.
- e) Cummerbund Side Plate Pocket Channel: The side plate pocket channel opening measurements shall be taken on a straight line along the outer edge of the cummerbund from bartack to bartack of the channel opening for both sides of the channel.

4.5.3 In-process Inspection:

In-process Visual Examination of Cut Parts, Fillers and Patterns. The cut parts for the vest shell assembly and the ballistic filler components shall be 100 percent inspected by vendor during the cutting process to determine that parts containing defects such as a hole, cut, are removed from production. Ballistic fillers shall be 100 percent inspected by vendor during the assembly of the individual groups to assure that they contain the correct number of plies, that no individual plies are pieced and they are marked correctly as to the size and number of plies. In addition to the above, inspection shall be made of working patterns to assure that they conform to government patterns in all respects. Whenever nonconformances are noted, correction shall be made to the item or items affected. Parts that cannot be corrected shall be removed from the production.

4.5.4 In-process Visual Examination of Ballistic Filler Assemblies for Size. Appendix C, Table IV provides visual examination criteria for ballistic filler. The lot shall be expressed in units of front and back ballistic fillers and side plate pocket ballistic fillers.

4.5.5 Area of Coverage. Square inches of coverage are measured by digitized patterns and comparison to working patterns.

4.5.6 Weight. The PLATE CARRIER will be examined for weight by component. Weights are taken on a tared scale and measured to the nearest 0.01 pound. Areal densities for production items may be calculated by weighing the ballistic filler insert divided by the pattern area. Areal densities for First Article Test may be calculated from weights and measurements taken from shoot-packs submitted for ballistic testing. Instructions for shoot-pack measurement are outlined in Appendix C Instructions for Shoot-Pack Measurement. Units shall be expressed in lb./sq.ft.

4.5.7 Thickness. Thickness is measured to the nearest 0.01 inch when measured under 0.5 psi when tested according to ASTM D-1777.

4.5.8 Fungus Test. Verification of compliance with the fungus requirement will be performed through the use of certified materials and coupon sampling. A fungus test will be performed on all non-certified materials. Tests will be performed in accordance with Method 508.4 of MIL-

STD-810. A sample of each non-certified material will be placed in the fungus test chamber for 28 days.

4.5.9 Infrared Reflectance. Spectral reflectance shall be evaluated initially and after laundering in accordance with Appendix A, Table III. Three accelerated launderings shall be performed using AATCC 61 Opt #A except; a 4 gram sample size shall be used. When evaluating the camouflage printed cloth, each color shall be tested separately. (Note: A sample size large enough to evaluate spectral reflectance shall be used. Ten (10) stainless spheres and 1993 AATCC Standard Reference Detergent without optical brightener shall be used. Spectral reflectance, initially and after laundering, will be obtained from 600 to 860 nanometers (nm), at twenty (20) nm intervals on an integrating sphere spectrophotometer or a spectroradiometer. The calibration of the instrument shall be traceable to the National Institute of Standards and Technology Perfect Reflecting Diffuser Calibration as stated in a Certificate of Traceability supplied by the instrument calibration standards. The spectral bandwidth shall be less than 26 nm at 860 nm. Reflectance measurements may be made by either the monochromatic or polychromatic mode of operation. When the polychromatic mode is used, the spectrophotometer shall operate with the specimen diffusely illuminated with the full emission of a source that simulates either CIE Source A or CIE Source D65. Measurements will be taken on a minimum of 2 different areas and the data averaged. The specimen shall be viewed at an angle no greater than 10 degree from normal, with the specula component included. Photometric accuracy of the spectrophotometer shall be within 1 percent, and wavelength accuracy within 2 nm. The standard aperture size used in the color measurement device shall be 1.0 to 1.25 inches in diameter. When the measured reflectance values for any color at four or more wavelengths do not meet the limits specified in paragraph 3.4.5, it shall constitute a test failure.

4.5.10 Accelerated Laundering Test. The test procedure shall be as follows using the equipment cited in AATCC 61. Cut five specimens containing predominantly black print, each 4.5" by 3.0 inches, from the basic material and then fold in half, with the face side out, to form a 2.25" x 3.0" dimension. Machine stitch the open edges together (seam allowance of no more than 0.25") to form a bag leaving an opening approximately 1.0" in length. Through the opening, add 35 stainless steel spheres. Close the bag by stapling or stitching. Place the bag in a stainless steel cylinder (one bag per cylinder) without the color transfer cloth; add 50 ml of type II P-D-245 detergent solution (0.5 percent by weight detergent solution) and 100 stainless steel spheres and close tightly. Place the stainless steel cylinder in a preheated Launder-Ometer set at a water bath temperature of 160 +/- 5 degree F. Agitate the cylinder for one (1) hour maintaining a constant temperature. At the end of the laundering cycle, remove the bag from the cylinder and rinse thoroughly in a beaker or in running tap water at 100 +/- 5 degree F for five (5) minutes with occasional stirring or hand squeezing. Remove excess water by squeezing in hand (not extracting) and then dry bag in automatic dryer set on permanent press cycle, 150 – 160 degree F for fifteen minutes (more than one bag can be dried together). If the bag breaks open to release the contained spheres at any time during the test, the test shall be considered invalid and another bag specimen shall be prepared and tested. Remove all spheres from the bag and evaluate each face of the bag without pressing or ironing the bag. Each face of the laundered bag shall be compared to the original sample (unlaundered) in accordance with AATCC evaluation procedure 1 for evaluation of Gray Scale for color change, and the rating shall be based on the portion of the black print exhibiting the most color loss. The lower of the two ratings of each bag shall be

recorded as the result for the bag. Failure of any of the five bags to meet required rating shall be considered a test failure.

4.5.11 Resistance to POL, insect repellent, sweat, and sea water after one laundering. PLATE CARRIER outershell carrier cloths shall be tested, after one laundering per 4.5.10, and after exposure to each DEET, POLs; motor oil, gasoline and weapon lubricant, sweat, and sea water for hydrostatic resistance in accordance with AATCC TM 127. A specimen for each test liquid (i.e., DEET, motor oil, etc) shall be 8 inches by 8 inches. The specimen shall be laid flat, face side up, on a glass plate, 8 inches by 8 inches by ¼ inch and three drops of each test liquid shall be applied to the center of the specimen. A glass plate the same dimensions shall be placed on the specimen and a four pound weight placed in the center of the glass plate assembly. After 16 hours, remove the specimen and test immediately for hydrostatic resistance. DEET test liquid shall be diethyltoluamide (O-I-503 Type II, Concentration A). The motor oil shall conform to ASTM D-4485, Grade CD-II. The weapon lubricant shall conform to MIL-PRF-63460 or commercial Break Free CLP, Santa Ana, CA or equal. The perspiration solution shall be made up in a 500 ml glass beaker by combining 3.0 grams sodium chloride, 1.0 gram of trypticase soy broth powder, 1.0 gram normal propyl propionate, and 0.5 gram liquid lecithin. Add 500 ml of distilled water, add a magnetic stirring bar, and cover the beaker. Place the beaker on a combination hot plate/magnetic stirrer apparatus. While stirring, heat the solution to 50 degree C until all ingredients are dissolved. While stirring, cool the solution to 35 degree C, remove cover, and dispense immediately with pipette or other suitable measuring device. Dispense 2 ml of perspiration solution at 35 degree C onto the center of an 8 inch by 8 inch by 1/4 inch glass plate. Place an 8 inches by 8 inches specimen face up. Dispense an additional 2 ml of perspiration solution onto the center of the specimen. A glass plate (do not rinse) of the same dimensions shall be placed on the specimen and a four pound weight placed in the center of the glass plate assembly. After 16 hours, remove and air dry specimen before testing for hydrostatic distance. See 4.6.1.1.1 for sea water formulation and sample preparation shall be the same as perspiration.

4.5.12 Laundering Procedure. The test specimens and ballast, if needed, shall be placed in an automatic washing machine set on permanent press cycle, high water level and warm (105 degree F +/- 5 degree F) wash temperature. The test specimens shall be taken from the vicinity of the fabric as the specimens for the initial test. 0.5 ounce (14 grams) of 1993 AATCC Standard Reference Detergent. The duration of the laundering cycle shall be 30 +/-5 minutes. After laundering, the specimens and ballast shall be dried in an automatic tumble dryer set on permanent press cycle, 150 to 160 degree F for approximately 15 minutes. The laundering equipment, washer and dryer, shall be in accordance with AATCC TM 135-1992.

4.5.13 Matching. The PLATE CARRIERS' individual components, assemblies, cloths, webbing and thread shall match each other when assembled into a complete system as well as match the standard samples viewed under filtered tungsten lamps that approximate artificial daylight and that have a correlated color temperature of 7500 +/- 200 K, with illumination of 100 +/-20 foot candles, and shall be a good match to the standard sample under incandescent lamplight at 2300 +/- 200K.

4.5.14 Ballistic Filler Abrasion Resistance. Testing shall be performed in accordance with ASTM D-3886 with the following exceptions: When a woven material is part of the ballistic layer system, it shall be used as the abradant mounted on the surface abrasion head; both the face and back of the test specimen shall be evaluated; the diaphragm shall be inflated to 4.0 psi with a 5.0 lb load. The abraded specimen shall be visually examined and rated according to the following criteria.

1. Severe change in surface appearance with most or all fibers in the center of the abrasion area being worn off or broken.
2. Moderate change in surface appearance with significant breakage of fibers in the center of the abrasion area and no appearance of a hole.
3. Slight change in surface appearance and minimal fiber breakage
4. No fabric structure change.

4.6 Ballistic Performance. First Article Testing will be conducted on 15 x 15 inch shoot-packs of the proposed ballistic material system. Lot Acceptance Testing will be conducted on the end item constructed of the approved ballistic material system (see 6.4). Failure to meet the requirements of any sub-test will constitute failure for the entire First Article Test or Lot Acceptance Test.

4.6.1 Ballistic Testing. General procedures and requirements are provided in 4.6.2 (see 6.5 for definitions).

4.6.1.1 Conditions. Dry specimens and specimens after; wet, hot temperature, cold temperature, accelerated aging and POL conditioning will be ballistically tested as specified in 3.5.2.2. Dry condition is the standard test condition specified in 4.6.2.3.

4.6.1.1.1 Wet Condition. Sea water shall be utilized for wet test conditions. Sea water formulation is 3% sodium chloride/0.5% magnesium chloride. The wet condition is achieved by completely submerging the PLATE CARRIER system in sea water at 70 +/- 5 degree F for 24 hours. The specimens are submerged such that the fluid is in contact with all exterior surfaces to allow maximum fluid penetration. A ten pound weight shall be placed on a 15" x 15" plate to distribute load to allow for maximum fluid penetration. Excessive water will be drained from the specimen by hanging vertically for 15 minutes and tested within 5 minutes with tests completed within 60 minutes.

4.6.1.1.2 Temperature Extremes Condition. For hot temperature extreme, the PLATE CARRIER system shall be heated in an oven operating at 155 + 10 degrees Fahrenheit for 6 +/- ¼ hours continuously. The test specimen shall be removed from the oven, mounted and ballistically tested as specified in 4.6.3. For cold temperature extreme, the test specimen shall be cold temperature exposed to -60 +/-10 degree F for 6 +/- ¼ hours continuously. The test specimen shall be removed from refrigeration, mounted and ballistically tested as specified in 4.6.3 within 5 minutes with tests completed within 60 minutes. If the test is not completed within 60 minutes the specimen shall be reconditioned for at least 1 hour at the temperature specified above.

4.6.1.1.3 Accelerated Aging. Accelerated aging for the PLATE CARRIER and/or subcomponents will be performed in general accordance with ASTM D1149, with the following modifications. The entire PLATE CARRIER or subcomponent under test will be subjected to treatment. A 30 lbs. weight will be applied to the test item during accelerated aging conditioning. All tested components will be conditioned for 72 hours at 40°C while maintaining a minimum of 50 parts per hundred million of ozone. The PLATE CARRIER and/or subcomponents do not require any additional tensile strain during accelerated aging conditioning. After accelerated aging conditioning, the PLATE CARRIER and/or subcomponents under test must remain at ambient atmospheric conditions for 24 hours prior to ballistic testing. Verify that the conditioned specimens perform as specified in 3.5.2.2.

4.6.1.1.4 POL Contamination. The ballistic material system specimens shall be immersed in each of the following; motor oil, and gasoline at room temperature. The specimens shall be placed flat in a pan with 1/8" – 1/4" of the POL fluid. A ten pound weight shall be placed on a 15" x 15" plate to distribute load to allow for maximum fluid penetration. The loaded specimen shall remain immersed for 4 hours at room condition. The specimen shall be hung vertically to drip dry for 15 minutes, excess oil shall be wiped from the surface to facilitate handling of the specimen. The specimen shall be ballistically tested within 30 minutes with testing completed within 60 minutes. If the testing is not completed within 60 minutes another specimen shall be conditioned as specified above and the testing shall continue with the second panel.

4.6.2 Ballistic Test Criteria. For all Protection Ballistic Limits (BL); V50, Vs/Vr, and V0 tests the following minimum information is required by the government to validate performance;

- a) Armor specimen description including exact materials, thickness, and areal density of armor system or ballistic system nomenclature, and sizes and weights of all components.
- b) Conditioning of armor specimen.
- c) Test projectile with exact nomenclature.
- d) Temperature and humidity measurements.
- e) Yaw angle.
- f) Angles of target obliquity.
- g) Velocity measurements of each test shot used to test the armor (regardless of whether that particular velocity was used in the V50 or V0 determination).
- h) Velocity loss and/or corrected striking/residual velocity for fragment simulating projectiles.
- i) PP (Partial Penetration) and CP (Complete Penetration) next to each shot velocity as determined.
- j) Angle of spall/debris ejection if applicable.
- k) Name of company performing tests.
- l) Type of gun barrel, caliber, and propellant used
- m) Range measurements including distances from gun barrel to velocity measurement devices and target.
- m) Calculated Ballistic Limit. In a situation where the V50 BL, Vs/Vr or V0 data sheet would compromise the Security Classification Guide for Armor Materials (see 2.2), the data sheet should exclude the specific projectile used during testing.

4.6.2.1 Projectile Velocity Determination. Projectile velocity measurement methods shall employ either high velocity lumiline screens or electrical contact screens which either open or close an electric circuit by passage of the projectile through the detector. Contact screens may consist of metallic foils separated by a thin insulating layer, or may consist of a circuit printed on paper with the circuit spacing such that the projectile passing through the screen will break the circuit. An electric counter type chronograph measuring to the nearest microsecond or as a minimum to the nearest 10 microseconds will be used with these measuring devices. As an alternative radiographic equipment calibrated to capture the projectile at various time intervals of flight can be used. For fragment simulating projectiles, velocity correction methodology shall be used to calculate the actual striking velocity and, where appropriate, actual residual velocity.

4.6.2.2 Weapon Mounting Configuration. The spacing from the weapon muzzle to the first pair of triggering devices shall be sufficient to prevent damage from muzzle blast and obstruction from smoke in case optical devices are used. Recommended distances can be found in USATECOM TOP 4-2-805. Spacing between triggering devices is a function of the expected velocity of the projectile being fired. In many instances, physical restriction, such as short overall distance from muzzle to test sample dictates the spacing of the triggering devices. The last pair of triggering devices shall be placed at least four (4) feet (122 cm) in front of the test sample and should be protected from possible damage resulting from fragments.

4.6.2.3 Environmental Test Conditions. All ballistic tests shall be performed as closely as possible to a standard atmosphere of 68 +/- 10 degree Fahrenheit and 50 +/- 20% relative humidity. Temperature and humidity measurements shall be recorded before the beginning of days test firings and every two hours thereafter

4.6.2.4 Projectile Yaw Determination. Projectile yaw shall be measured for each firing by yaw cards, flash radiograph or photography. Any round for which yaw is determined to be greater than 5 degrees shall be disregarded in the calculation of the ballistic limit. The measurement system employed should be capable of measuring yaw within an accuracy of 1.0 degrees.

4.6.3 V50 BL Calculation. V50 will be determined in accordance with MIL-STD-662F. For Lot Acceptance Testing, three (3) Partial Penetration (PP's) and three (3) Complete Penetrations (CP's) within a 125 ft/sec velocity spread or five (5) Partial Penetration (PP's) and five (5) Complete Penetrations (CP's) within a 150 ft/sec velocity spread yield the V50 BL determination that will be accepted. First Article Testing will require five (5) Partial Penetrations (PP's) and five (5) Complete Penetrations (CP's) within a 150 ft/sec velocity spread to determine V50 BL.

4.6.3.1 PP and CP Determination for V50. Complete and partial penetrations (see 6.6) will be determined based on the impressions left on an aluminum witness sheet. A 0.020 in. (0.051 mm thick 2024 T3 sheet of aluminum) will be placed 6 + 1/2 in. (152 + 12.7 mm) behind and parallel to the target. The aluminum witness sheet will be at least 15 x 15 in. size and be of sufficient size to capture all fragments resulting from the ballistic event, mounted rigidly around its parameter and placed so that the target impact location is approximately at the center of the aluminum sheet. The following test conditions apply:

- a) Test samples should be 15.0 x 15.0 inch square size panels and configured in the proposed final armor material system for the First Article Testing Only (see 6.4).
- b) PLATE CARRIER base vest panels configured in the armor material system approved under the First Article Test shall be used for Lot Acceptance Testing.
- c) For all size test panels a metallic (approx. 0.20 inch thick aluminum or steel) frame with minimum 1.4 inch webbing shall be employed to restrain the test material during ballistic impact.
- d) The test panel will be sandwiched between 2 frames and restrained with mechanical or pneumatic clamping devices at each of the four corners of the frame.
- e) The restraining frames will be cut so that a ballistic window with minimum sizing of 12.0 x 12.0 inch square will be used.
- f) Shot spacing shall be based on impact point.
- g) All shots shall be at least 2.5 inches from any edge of the samples.
- h) Test shots shall be sufficiently spaced so that sequential shots are not influenced by previous impact areas. A minimum shot spacing of 2.5 inch is required but 3.0 inch is recommended especially when testing against handgun projectiles.
- i) Depending on the test panel size it may be necessary to use 2-3 panels for the V50 determination.
- j) Test specimens shall be reconditioned to a smooth shape after every shot.

4.6.3.2 Vs/Vr and V50 Test Sample Mounting. Restraint is required during testing so that the material is not pulled through the ballistic test window frame. Unless otherwise stated the following conditions shall be performed during V50 testing. The armor test sample shall be secured on the test target mount with the impact side at the appropriate angle to the line-of-flight of the projectile. The frame supports, clamps or mounting fixtures must be capable of retaining the sample and withstanding shock resulting from ballistic impact by the test projectiles. The test sample mount shall be capable of adjustment of moving the sample in the vertical and horizontal directions so that the point of impact can be located anywhere on the sample and so that appropriate degree obliquity impacts can be achieved anywhere on the sample. The test sample mount shall be capable of rotating on the vertical or horizontal axis so that various obliquity attack angles can be achieved.

4.6.4 Vs/Vr Testing. The Vs/Vr testing is for Government reference only and is done by starting at the upper end of the velocity spectrum and working down to below the V50. Starting velocities are provided in Appendix D, Table III. Testing is performed at 0 degrees and 45 degrees obliquity for all RCC fragmentation projectiles. Both the striking velocity (Vs) and the residual velocity (Vr) of the projectile must be measured. Yaw of the striking projectile should be measured for all shots. Approximate starting velocities are listed below. From the starting velocity subsequent shots are taken at approximately 400 - 500 ft/sec increments down to below the V50 where there are no longer any complete penetrations. Additional shots are then taken above and below the V50, in a similar manner to standard V50 test methodology, to characterize the performance of the armor system in this area. This testing will require between 15 and 20 valid shots for each size RCC. Approximately half of the shots should be in the regime between the starting velocity and just above the V50. Shots that would not be considered valid include: excessive yaw of the striking projectile; incomplete measurement of the residual velocity of a

complete penetration; impacts at incorrect obliquity; or impact closer than 1 inch to any previous impact.

4.6.5 V0 Determination for Acceptance. For V0 or full protection (no complete penetrations), a minimum velocity (muzzle plus 50 ft/sec) will be the requirement. The following conditions apply; No complete penetration at the maximum specified shot pattern specified is the minimum requirement. Closer positioning of shots without complete penetration is a desired requirement.

- a) Test samples should be 15.0 x 15.0 inch square size panels and configured in the proposed final armor material system for the First Article Testing Only (see 6.4).
- b) PLATE CARRIER base vest panels configured in the armor material system approved under the First Article Test shall be used for Lot Acceptance Testing.
- c) Samples will be mounted on clay block described below (see 4.6.5.2).
- d) The first shot will be $2.75 \pm 1/4$ " inch from any edge.
- e) The next shot shall be located 3.5 inch $-0/+1/2$ " from the first shot and at the weakness point in the configuration, e.g.; seamed area or non-uniform area of design.
- f) The third shot location should be positioned 3.5 inch $-0/+1/2$ " from any of the 2 previous test shots.
- g) The fourth and fifth shots shall be located 3.5 inch $-0/+1/2$ " from any previous test shots and tested at 30 degrees obliquity.
- h) The transient deformation shall be measured (see 4.6.5.1) after the third and fifth test firings
- i) Test shots should be staggered at least 0.25 inch off the horizontal and vertical lines of any previous shots.
- j) Test specimens shall be reconditioned to a smooth shape after every shot.

4.6.5.1 Back Face Deformation (BFD) Measurement. The back of the armor test specimen will be attached to a block of non-hardening, oil-based molding clay so that no movement of the test samples occur before, during or after the ballistic impact. The test fixture containing the clay backing material shall be in the form of a single block at least 4.0 in. thick and 24 x 24 in. length and height. The clay backing material shall be conditioned in its fixture, using a heated chamber or enclosure. Conditioning time, temperature, and corresponding drop test performance may change as a function of backing material age and usage. Actual conditioning temperature and recover time between uses will be determined by drop test results. Additional clay, conditioned to the same initial temperature as the fixture, shall be used to fill voids and restore the front surface of the backing material as needed. The clay consistency should be such that depression of 25mm (± 3 mm) in depth is obtained when a 1 kg (± 10 gm) (2.2 lb ± 0.35 oz) cylindrical steel mass, 44.5mm (± 0.5 mm) (1.75 ± 0.02 in) in diameter and having a hemispherical striking end is dropped from a height of 2 m (± 2 cm) (6.56 ft ± 0.07 ft) onto one of its square faces. The specimen will be strapped or taped to the surface of the clay material. Ballistic testing will be performed at 0 degrees obliquity and 30 degree obliquity. Back-face deformations in the clay will not exceed 44 mm. when measured from the original undisturbed surface of the backing material to the lowest point of the depression. There are two acceptable methodologies to deriving the Back Face Deformation.

Methodology 1 - All Back Face Deformation measurements will only be conducted at 0-degree obliquity to the original undistributed surface of the backing material. Indentation measurements will utilize measurement devices (+/- 0.1 mm accuracy) incorporating a fixed reference “guide” (see Figure xx) that can rest solidly upon two edges of the fixture, establishing the reference plane across the diameter of the indentation. The distance between the reference “guide” and original undisturbed surface will be measured at the point of intended impact prior to impact. The distance between the reference “guide” and the lowest point of depression will be measured after impact. Back Face Deformation will be the difference between the two measurements.

Methodology 2 - Back Face Deformation measurements will be taken utilizing a certified, calibrated laser scanner measurement instrument, which provide a means to accurately measure the difference between the original undisturbed clay surface and the deepest point of BFD signature. The perpendicular distance between the original surface and the deepest point of depression, with reference to the original undisturbed surface, will be measured after the test record shot impact. The laser scanner measurement instruments shall be certified by ATEC and use a software package capable of meeting the following requirements:

- Uniform sample: 0.5mm
- Noise reduction: Data with 0.05mm limit on point movements.
- Wrap data points with polygonal surface (*w/o noise reduction*).
- Data Smoothing: Fill holes (*curvature based hole filling*.)
- Removal of intersecting triangles.
- Spike removal: 10% (*run 2 times in a row*)
- 3D: Comparison to determine the deepest point.

The software package shall ensure the deepest point is not located within a crack in the clay. If a crack in the clay is determined to be the deepest point, the software smoothing function will fill-in the crack and find the actual deepest point. The software shall also ensure that the area identified as the deepest point is has a minimum area of at least 0.7 mm x 0.7mm in width and length.

4.6.5.2 Test Sample Mounting. The molding clay block shall be rigidly held by a suitable (metal) stand. The armor test sample must remain coplanar throughout the test and shall be secured in the vertical position, perpendicular to the projectile line of flight. The frame supports must be capable of retaining the sample and withstanding shock resulting from ballistic impact. The test sample mounting shall be capable of adjustment for moving the sample in the vertical or horizontal positions so that the point of impact can be located anywhere on the sample and rotation on the vertical axis so that 0 and 30 degree obliquity impacts can be achieved anywhere on the sample.

4.6.6 Flexibility. The ballistic filler fabric subcomponents of the system shall be tested in accordance with ASTM D 1388, Standard Test Method for Stiffness of Fabrics, with the following noted exceptions, to determine the flexural rigidity in units of cm-g for each component. The restriction of size of sample may be waived such that end item ballistic filler fabric subcomponents may be tested. These results are then used to calculate an overall system flexibility as follows:

$$\text{System Stiffness} = \sum \left[\frac{G_{i, \text{warp}} + G_{i, \text{fill}}}{2} \right] \times \text{Layers}_i$$

Where:

- i = different fabric components in the system
- $G_{i, \text{warp}}$ = Flexural Rigidity in the warp direction (cm-g)
- $G_{i, \text{fill}}$ = Flexural Rigidity in the fill direction (cm-g)
- Layers_i = Number of total layers of the component system

The System stiffness shall be less than 225 cm-g when calculated as above.

Example Calculation:

A system is composed of 12 plies of material a and 6 plies of material b. Component flexural rigidities are as follows:

Material A:

$G_{A, \text{warp}} = 4.000 \text{ cm-g}$

$G_{A, \text{fill}} = 6.000 \text{ cm-g}$

Material B

$G_{B, \text{warp}} = 7.000 \text{ cm-g}$

$G_{B, \text{fill}} = 8.000 \text{ cm-g}$

$$\text{System stiffness} = [(4.000+6.000)/2 \times 12] + [(7.000+8.000)/2 \times 6] = 105.000 \text{ cm-g}$$

The calculated system stiffness is less than 225cm-g and is therefore acceptable.

4.7 Operating Requirements Verification. Complete each verification in this paragraph.

4.7.1 Insertion Demonstration. One barehanded person shall demonstrate insertion of the ESAPI into the PLATE CARRIER base vest front and back pockets as well as the insertion of the Enhanced Side-SAPI into both side plate pockets without tools or special aids. An insertion demonstration may be performed with Mock ESAPI's conforming to drawings 2-6-0588, 2-6-0589, 2-6-0590, 2-6-0591 and 2-6-0592 and the maximum thickness requirement. The respective pocket flaps shall be closed and secured with the ESAPI or Enhanced Side-SAPI. It shall be possible to insert and remove the Inserts into and out of the pocket without effort. A defect shall be scored if any Insert must be forced into or removed from the pocket, or if excessive force is needed to secure the flap.

4.7.2 Insertion Test Using Protective Hand Gear. Insert ESAPI into the PLATE CARRIER pocket while separately wearing standard Army cold weather gloves (NSNs 8415-01-319-5514, Shell and 8415-01-319-9042, Glove) and chemical protective hand wear (NSN 8415-01-033-3517). Perform insertion into government furnished carrier in a maximum of 30-seconds.

4.7.3 Ballistic Filler Extension. Insert ESAPI into the corresponding sized PLATE CARRIER front and back base vest SAPI pocket. The amount of ballistic filler extending beyond the edge of the Insert will be measured by holding the garment taut with a metal measuring device and measurements taken to the nearest 1/16 inch. Measurements shall be taken at a minimum from the top edge, bottom edge and parallel left and right edges of the Insert. Any measurement resulting in less than 1 inch of ballistic filler extending beyond the edge of the Insert shall be

scored as a defect. Verification of required ballistic filler extension may require physical destruction of the carrier.

4.8 Drag Strap Seam Strength. Testing shall be accomplished using a constant rate-of-extension test apparatus capable of accurately measuring loads up to $1,000 \pm 2$ lb. The sample (an actual vest or representative back panel only, as appropriate) shall be firmly clamped across its full width to the base of the test apparatus using a steel bar or other device capable of completely restraining the sample during testing. The clamp shall be placed parallel to, and within 0.25 in of the bottom of the drag strap (i.e., on the SAPI pocket flap). The center of the drag strap shall be directly in line with the center of the loadcell and pulling head. The drag strap shall be affixed to the load cell and pulling head through a loop of 1-in webbing (A-A-55301 Type VI) having a gage length of 12 ± 1 in. A preload of 1 lbf shall be applied prior to the start of testing. The loadcell and pulling head shall be advanced at a constant rate of 2 in./min until failure. The following minimum data shall be recorded: Extension and Load at first-stitch failure (if applicable), Extension and Peak Load; Mode of Failure (i.e., seam failure, fabric tear-out; handle break).

5. PACKAGING

5.1 Packing. For acquisition purposes, the contract or order shall specify complete packaging requirements. When DOD personnel perform material packaging, those personnel need to contact the responsible packaging activity to ascertain requisite packaging requirements. The Inventory Control Point packaging activity within the Military Department of defense Agency, or within the Military Department's Systems Command, maintains packaging requirements. Packaging data retrieval is available from the managing Military Department's or defense Agency's automated packaging files, CD-ROM products, or by contacting the responsible packaging activity.

6. NOTES: (This section contains information of a general or explanatory nature that may be helpful, but is not mandatory.).

6.1 Intended Use. The multiple threat body armor is a modular body armor providing multiple levels of ballistic protection depending on the system configuration. The PLATE CARRIER provides protection from conventional fragmenting munitions and 9mm handgun. The area of protective coverage of the body is dictated by the number of modular components worn to extend coverage. PLATE CARRIER protection is increased to protect vital organs from multiple hits against small arm rifles and indirect fire flechette when front, back and side small arms protective inserts are worn.

6.2 Acquisition Requirements. The Procuring activity should specify in the Acquisition documents the following:

- a) Title, and date of this document.
- b) When First Article Test, and pre-production items are required.
- c) Camouflage required.
- d) Size Tariff

e) Contractually approved ballistic package(s) to include package name, complete description, and First Article Test acceptance letter.

6.3 Simulant/Surrogate Shoot-Pack. A Simulant/Surrogate Shoot-Pack system of PLATE CARRIER body armor may be used to represent the ballistic resistant materials of the PLATE CARRIER system. All surrogate shoot-pack systems will consist of (1) a base vest ballistic filler packet and (2) a ballistic filler carrier with insert pocket.

The ballistic filler packet for PLATE CARRIER base vest will be 15 x 15 inches in size consisting of X plies of the proposed ballistic material system used in PLATE CARRIER base vest (see 3.3.1.4 and 3.3.1.13). The ballistic packet will be stitched diagonally across the 4 corners with a 5-inch line of 50 TEX Aramid thread at 5 to 10 stitches per inch. When the ballistic filler is an asymmetric system of different materials, the filler packet will be labeled to clearly indicate the strike face from the back face.

The ballistic filler carrier will have an insert pocket capable of holding the largest insert stitched on the face fabric. The pocket cover shall consist of the same front outer shell fabric used in the construction of the PLATE CARRIER base vest. The face fabric of the ballistic filler carrier shall consist of the same front middle shell fabric using in the construction of the PLATE CARRIER base vest. The insert pocket will be stitched on three sides to the face fabric with nylon or polyester thread. The top edge of the pocket will have a minimum of 5 inches of not less than 0.5 inch wide hook and loop fastener centered and stitched at the top. The ballistic filler carrier back cover shall consist of the same front inner shell fabric used in the construction of the PLATE CARRIER base vest. The face fabric and back cover of the ballistic filler carrier will be stitched together on 3 sides with nylon or polyester thread to form a pocket to hold the ballistic filler packet(s). The fourth side will remain unstitched but will have a minimum of 5 inches of not less than 0.5 inch hook and loop fastener centered and stitched to the top. Each ballistic filler carrier will be individually serialized and clearly labeled to indicate the strike face.

All surrogate shoot-pack systems shall be clearly labeled to indicate the strike face of the system.

6.4 Ballistic Testing Definitions. The following definitions are provided to assist in understanding the test procedures:

Fair Impact. All three impacts will be at 0 degrees obliquity. A projectile that impacts the armor at an angle of incidence no greater than + 5 degrees from the intended angle of incidence will be considered a fair impact.

Partial Penetration PP(P). Any fair impact that is not a complete penetration shall be considered a partial penetration.

Complete Penetration (CP) for V50 Testing. A complete penetration occurs when the impacting projectile or any fragment thereof, or any fragment of the test specimen perforates the witness plate resulting in a crack or hole which permits light passage when a 60-watt, 110-volt bulb is placed behind the witness plate.

Complete Penetration (CP) for Acceptance Testing. A complete penetration will have occurred when the projectile, fragment of the projectile or fragment of the armor material is imbedded or passes into the clay backing material used to measure transient deformation. Paint or fibrous materials that are emitted from the back of the test specimen and rests on the outer surface of the clay impression are not considered a complete penetration.

Residual Velocity. The velocity at which a projectile exits the rear surface of an armor sample. Used only for Vs/Vr testing.

Areal Density (AD). A measure of the weight of the armor per unit area, usually expressed in pounds per square foot (lb. /ft²) or kilograms per square meter (kg/m²) of surface area.

Obliquity. A measure, normally in degrees, of the extent to which the impact of a projectile on an armor material deviates from a line normal to the target. Thus, a projectile fired perpendicular to an armor surface at 0 degrees obliquity.

Spall. The detachment or delamination of a layer of material or the ejection of projectile/armor material in the area surrounding the location of impact, which occurs on the front of the armor surface. Spalling may be a threat mechanism even when penetration of the armor itself is not complete.

Yaw. Projectile yaw is the angular deviation of the longitudinal axis of the projectile from the line of flight at a point as close to the impact point on the target as is practical to measure.

V50 Ballistic Limit (BL). In general, the velocity at which the probability of penetration of an armor material is 50 percent.

6.5 Contents of Labels, and Use and Care Instructions: see Appendix E.

APPENDIX A – MATERIAL PROPERTIES FOR PLATE CARRIER SUBCOMPONENTS

Table I. Cloths: Base Vest Components Outer and Inner Shell (see 3.2.1)

Characteristic	Outer Shell Cloth*	Inner and Middle Shell Cloth**
Weight (oz/yd ²) (max.)	12.0	8.0
Breaking Strength; lb. (min.) Warp X Filling	500x300	360 X 270
Dimensional Stability; % (max.) Warp X Filling	3.0 x 2.0	3.0 X 2.0
Abrasion Resistance: (min.) Number of Cycles	1000	1000
Water Repellency: Spray Rating (min) Initially After 1 Laundering	100,100,90 90,80,80	100,100,90 90,80,80
Hydrostatic Resistance: cm (min) Initially and After 1 Laundering After 1 Laundering and POL Contamination After 1 Laundering and Insect Repellent Contamination After 1 Laundering and Sweat Contamination After Laundering and Sea Water Contamination	35	35
Dynamic Absorption: % (max.) After 1 Laundering	20	20
Resistance to Organic Liquids (min) After 1 Laundering	No wetting by n-dodecane	No wetting by n-dodecane

*3.3.1.1, 3.3.1.9

** 3.3.1.2, 3.3.1.12

Table II. Foam Characteristics (see 3.2.6)

Characteristic	Requirement
Density	3.1 lb/cu ft
Thickness	0.25 in
Compression Strength @ 25% deflection @ 50% deflection	6 psi 15 psi
Elongation at Break	220% (min)
Tear Resistance	19 lbf/in (min)
Water Absorption of Surface	0.04 lb/sq ft (max)

Table III. Camouflage Shades (see 3.4.4)

COMPONENT(S) OR PART(S)	Type 1 – Color	Type 2 - Color
(1) Outer Shell: Base Vest Cummerbund Side Plate Pouches	Coyote 498	3 Color Pattern: Desert Sand 503 – Ground Shade Foliage Green 502 Urban Gray 501
(2) Base Vest Inner Lining	Coyote 498	Foliage Green 504
(3) Ballistic Panel Cover MiL-DTL-508	Tan 380	Foliage Green 504
(4) Webbing Binding Tape Hook & Loop Fastener Thread Elastic Webbing Labels	Coyote 498 Tan 380 or Desert Sand 503*	Universal Camouflage Pattern* Foliage Green 504* Tan 380 or Desert Sand 503*
(5) Hardware Buckles Snaps	Coyote 498 Black	Foliage Green 504 Black

*As specified in sections 3.2 and 3.3.1

Table IV-A. Infrared Reflectance Requirements (percent) Coyote 498 (see 3.4.6)

Wavelengths Nanometers (nm)	Min	Max
600	8	20
620	8	20
640	8	22
660	8	24
680	12	24
700	12	34
720	16	42
740	22	46
760	30	50
780	34	54
800	36	56
820	38	58
840	38	58
860	40	60

Table IV-B. Infrared Reflectance Requirements (percent) Universal Camouflage (see 3.4.6)

Wavelengths Nanometers	Desert Sand 500		Urban Gray 501		Foliage Green 502	
	Min	Max	Min	Max	Min	Max
600	28	40	12	26	8	18
620	30	42	14	26	8	18
640	34	48	14	28	8	20
660	38	56	14	30	10	26
680	44	60	18	34	10	26
700	46	66	24	38	12	28
720	48	68	26	42	16	30
740	48	72	30	46	16	30
760	50	74	32	48	18	32
780	54	76	34	48	18	34
800	54	76	34	50	20	36
820	54	76	36	54	22	38
840	56	78	38	54	24	40
860	56	78	40	56	26	42

Table IV-C. Infrared Reflectance Requirements (percent) Foliage Green 504 (see 3.4.6)

Wavelengths Nanometers (nm)	Min	Max
600	8	18
620	8	18
640	8	20
660	10	26
680	10	26
700	12	28
720	16	30
740	16	30
760	18	32
780	18	34
800	20	36
820	22	38
840	24	40
860	26	42

Table IV-D. Infrared Reflectance Requirements (percent) Tan 380 and Desert Sand 503
(see 3.4.6)

Wavelengths Nanometers (nm)	Tan 380		Desert Sand 503	
	Min	Max	Min	Max
600	28	40	28	40
620	30	42	30	42
640	32	48	34	48
660	34	54	38	56
680	40	58	44	60
700	42	60	46	66
720	42	60	48	68
740	44	62	48	72
760	44	62	50	74
780	46	64	54	76
800	48	64	54	76
820	48	64	54	76
840	48	64	56	78
860	50	66	56	78

Table IV-E. Infrared spectral reflectance requirements for Foliage Green 504 Acetal Hardware (see 3.4.6)

Wavelengths Nanometers (nm)	Min	Max
600	8	18
620	8	18
640	8	18
660	10	26
680	10	26
700	12	28
720	20	36
740	26	40
760	30	52
780	32	56
800	32	60
820	34	60
840	36	60
860	36	60

TABLE V-A: Minimum Ballistic Panel Area; Sq. In. (see 3.5)

Ballistic Panel	X-Small	Small	Medium	Large	X-Large
Front Panel Wide	137	159	180	202	224
Front Panel Narrow	131	153	172	193	216
Back Panel Wide	158	187	212	237	264
Back Panel Narrow	152	180	203	227	253
Side Plate Pouch Panel	69	69	69	69	69

TABLE V-B: Bartack (see 3.5.3.4)

Characteristic	Stress points; All cloth	Webbing hangers; Webbing + cloth
Length; in	3/8" min	3/4 " +/- 1/16"
Holding Strength: lb. (min.)	60	250

TABLE V-C: Base Vest Finished Measurements; Inches* (see 3.5)

Size	Center Front Length +/- 1/2"	Front Width +/- 1/2"	Center Back Length +/- 1/2"	Back Width +/- 1/2"
X-Small	14 1/2	15 1/4	16	14 1/4
Small	14 3/4	16 3/4	16 1/4	15 3/4
Medium	15 1/4	17 1/2	17	16 1/2
Large	16	18 1/4	17 3/4	17 1/4
X-Large	16 3/4	19	18 1/2	18

TABLE V-D: PLATE CARRIER Cummerbund Finished Measurements; Inches* (see 3.5)

Size	Center Length +/- 1/2"	Center Width +/- 1/2"	Cummerbund Side Plate Pocket Channel +/- 1/2"
X-Small – Small	20 1/2	6 5/8	12
Medium	23 1/2	6 5/8	12
Large – X-Large	26 1/2	6 5/8	12

* See paragraph 4.5.2.1 for measurement directions.

Table VI. Release Cable (see 3.5.3.9)

Vest Size	Long Section (Inches)
X-Small to Small	27 1/2
Medium	27 1/2
Large to X-Large	31 1/2

Table VII. Chest Circumference for Base Vest Outershell Label (see 3.6)

Size	Chest Circumference (Inches)
X-Small	29-33
Small	33-37
Medium	37-41
Large	41-45
X-Large	45-49

Table VIII. Waist Circumference for Cummerbund Label (see 3.6)

Size	Waist Circumference (Inches)
X-Small – Small	NA
Medium	NA
Large – X-Large	NA

APPENDIX B: BALLISTIC PROTECTION REQUIREMENTS

**Table I: Base Vest assembly and Side Plate Pockets
Fragmentation Protection; Minimum V50** (see 3.5.2.2)

Fragment Projectile	V50 @ 0 degree DRY: ft/sec	V50 @ 0 degree WET: ft/sec	V50 @ 45 degree DRY: ft/sec
2 gr. RCC	2710	2575	2800
4 gr. RCC	2400	2300	2460
16 gr. RCC	2050	1920	2080
64 gr. RCC	1660	1610	1660
16 gr. RCC; After hot and cold temperatures, accelerated aging	2000	N/A	N/A
16 gr. RCC; After POL	1900	N/A	N/A
17 gr. FSP	1850	N/A	N/A

Table II: Handgun Ballistic Characteristics (see 3.5.2.3)

Projectile - 9mm, 124 gr., FMJ Remington	V50 @ 0 degree; ft/sec (min.)	V0 Acceptance; @ 0 & 30 degree ft/sec	Deformation; mm (max.)
Required	1525	1400 +50/-0	44
Desired	1625	1500 +50/-0	44

APPENDIX C: NON-BALLISTIC REQUIREMENTS AND VERIFICATIONS

Table I. Requirements and Verifications (see 4.5)

CHARACTERISTIC	REQUIREMENT PARAGRAPH	VERIFICATION PARAGRAPH	First Article Test	Lot Acceptance Test
<i>Cloth Outer and Inner Shell</i>	3.2.1	4.5	X	COC
Breaking Strength	3.2.1	ASTM D5034, G-E or G-T	X	COC
Dimensional Stability	3.2.1	AATCC 96 Option 1C, A	X	COC
Outershell and Innershell Cloth Abrasion Resistance	3.2.1	ASTM D 3884 (Footnote 1)	X	COC
Spray Rating: Initial 1 Laundering	3.2.1	AATCC 22 4.5.12 & AATCC 22	X	COC
Hydrostatic Resistance: Initial After 1 Laundering After 1 Laundering and POL Contamination After 1 Laundering and Insect Repellent After 1 Laundering and Sweat Contamination After 1 Laundering and Sea Water Contamination	3.2.1	AATCC 127 4.5.11 & AATCC 22 4.5.12 & AATCC 22	X	COC
Dynamic Absorption: After 1 Laundering	3.2.1	4.5.11 & AATCC 70	X	COC
Resistance to Organic Liquids: Initial After 1 Laundering	3.2.1	AATCC 118 4.5.11 & AATCC 118	X	COC
Cloth Ballistic Panel Cover.	3.2.2	4.3.1	COC	COC
Webbings and Tapes	3.2.3	4.3.1	COC	COC
Elastic	3.2.4	4.3.1	COC	COC
Fasteners, Hook and Loop	3.2.5	4.3.1	COC	COC
Foam	3.2.6	4.3.1	COC	COC
Polyethylene	3.2.7	4.3.1	COC	COC
Cable	3.2.8	4.3.1	COC	COC

Cable Sleeves	3.2.9	4.3.1	COC	COC
Thread.	3.2.10	4.3.1	COC	COC
Buckle, Side Release	3.2.11	4.3.1	COC	COC
Tension Lock	3.2.12	4.3.1	COC	COC
Loop	3.2.13, 14, 15	4.3.1	COC	COC
Design	3.3	4.4	X	X
Patterns	3.3.1	4.4	X	X
System Performance Requirements	3.4	4.4		
Functional Integration	3.4.1	4.4	X	X
Fungus Resistance	3.4.2	4.5.8	X	COC
Includes Use & Care Instruction (yes/no)	3.4.3	4.4		YES/NO
Camouflage	3.4.4	4.1	X	X
Infrared Reflectance	3.4.5, 3.2.3	4.5.9	X	COC
Matching	3.4.6	4.5.13	X	COC
Pattern Execution	3.4.7	4.1	X	COC
Colorfastness to:	3.4.8	4.1		
Laundering: 3 Cycles	3.4.8	AATCC 61 OPTION IA	X	COC
Accelerated Laundering	3.4.8	4.5.10	X	COC
Light	3.4.8	AATCC 16 OPTION A or E (Exposure shall be 40 hrs or 170 kilojoules)	X	COC
Crocking	3.4.8	AATCC 8	X	COC
Frosting	3.4.8	AATCC 119; EXCEPT IT SHALL BE 300 CYCLES	X	COC
Perspiration	3.4.8	AATCC 16; EXCEPT BOTH ACID AND ALKALINE TEST SHALL BE PERFORMED	X	COC
Area of Coverage	3.5	4.5.3, 4.5.4, 4.5.5	X	COC
Finished Dimensions	3.5	4.5.2, 4.5.3, 4.5.4	X	COC
Ballistic Filler Weight & Areal Density	3.5.2.1.1	4.5.5, 4.5.6	X	COC
Non-Removable Ballistic Panel	3.5.2.1	4.5.4	X	X

Subcomponent				
Ballistic Filler	3.5.2.1.1	4.5.5, 4.5.6	X	X
Flexibility	3.5.2.1.2	4.6.6	X	COC
Ballistic Filler Abrasion Resistance	3.5.2.1.3	ASTM D-3886 4.5.14	X	COC
PLATE CARRIER Construction	3.5.3	4.3.1 & 4.5.1	X	X
Hook and Loop Fastener	3.5.3.1	4.5.1	X	X
Stitching	3.5.3.2	4.5.1	X	X
Automatic Stitching	3.5.3.3	4.5.1	X	X
Bartacks	3.5.3.4	4.5.1	X	X
Bartack Alignment for MOLLE Pocket Attachment	3.5.3.5	4.5.1 & 4.5.2	X	X
Buttonholes.	3.5.3.6	4.5.1	X	X
Drag Strap	3.5.3.7	4.8	X	COC
Release Cable Dimensions	3.5.3.8	4.5.1	X	X
Binding	3.5.3.9	4.5.1	X	X
Torso Adjustment	3.5.3.10	4.3.1 & 4.5.1	X	COC
Emergency Release Mechanism	3.5.3.11	4.5.1	X	X
Labels	3.6	4.5.1	X	X
SAPI Pocket	3.7	4.4, 4.7.1-3	X	X

Footnotes:

1) H-18 abrasive wheel with 1000 gm load shall be used. A hole shall be defined as the wear through of one (1) warp and one (1) filling yarn at the same location.

Table II. END ITEM DEFECTS (see 4.5.1)

EXAMINE	DEFECT	CLASSIFICATION*	
		MAJOR	MINOR
Cloth	Any hole (except drill hole), cut, or tear larger than 1/8 inch.	101	
	Any hole (except drill hole), cut, or tear less than 1/8 inch.		201
	Any abrasion marks, broken or missing yarns or multiple floats		202
	Any mend, darn or patch.	102	
	Needle Chews.	103	
Webbing or Tape	Any hole, cuts, tears, or smash.	104	
	Not firmly and tightly woven, edges frayed or scalloped.	105	
	Multiple floats.		203
	Abrasion mark, slub, or broken end or pick.	106	
	Ends not fused as required.		204
Cabling	Any hole, cut or tear, incomplete securing of sleeve, impairing function.	107	
	Ends not finished as required.		205
Fastener Tape	Any hole, cut or tear, hooks flattened, broken or missing, impairing function.	108	
	Stitched in the selvage edge		206
Seams and Stitching:			
Open Seams	½ inch or less.		207
	More than ½ inch NOTE: A seam shall be classified as an open seam when one or more stitched joining a seam are broken or when two or more consecutive skipped or runoff stitches occur.	109	
Raw Edges	More than ½ inch when securely caught in stitching. NOTE: Raw edges not securely caught in stitching shall be classified as open seams.		208
Seam & Stitch Type	Wrong seam or stitch type.	110	
Stitch Tension	Tension loose, resulting in loose bobbin or top thread.		209
	Excessively tight, resulting in puckering of material.		210
Bartacks	Any bartack omitted.	111	
	Any bartack not as specified or not in specified location.		211
	Loose stitching, incomplete or broken.		212
Stitching Ends	Not secured as specified.		213

Thread Breaks, Skipped Stitches, or Run-Offs.	Not over stitched as specified. NOTE: Thread breaks or two or more consecutive skipped or run-off stitches not over stitched shall be classified as open seams.		214
Component & Assembly	Any area of ballistic filler bunched (i.e. does not lie flat)	112	
	Any component part omitted or not as specified (unless otherwise classified herein)	113	
	Needle Chews.	114	
	Any mend, darn, patch, holes, splice or other unauthorized repair.	115	
Location Markings	Printed marking more than 1/32 inch in width or not covered by component part.		215
Label	Missing, incorrect, illegible.	116	
Shade	Individual components do not provide a good match one another and the standard	117	
Plate Pocket	Insert does not fit and cannot be secured into plate pocket	118	

*The presence of a number designates either major or minor. The value of the number is for internal inspection purposes only.

Table III. END ITEM DIMENSIONAL INSPECTION

EXAMINE	DEFECT	CLASSIFICATION*	
		Major	Minor
Dimensional (overall)	Smaller than nominal dimensions less applicable minus tolerance indicated but not smaller than nominal dimensions less twice the applicable minus tolerance.	119	
	Larger than nominal dimensional and applicable plus tolerance		217
Component and Location Dimensions	Not within specified tolerance		218
Stitch Margin or Gage	Not within specified tolerance		219
Box, Box-X and stitching	Dimensions not within specified tolerance		220
Hardware	Not spaced within specified tolerance		221

*The presence of a number designates either major or minor. The value of the number is for internal inspection purposes only.

Table IV. VISIAL EXAMINATION OF BALLISTIC FILLER SIZE (see 4.5.4)

Examine	Defect	Classification*	
		Major	Minor
Size of Individual Ballistic Filler Assembly	A) Smaller than cutting pattern:		
	(1) 3/16 inch to 3/8 inch at any point around the periphery 1/ 2/		222
	(2) More than 3/8 inch at any point around the periphery 1/ 2/	120	
	(3) 1/8 inch up to 3/16 inch around entire periphery 2/		223
	(4) More than 3/16 inch around entire periphery 2/	121	
	B) larger than cutting pattern by 3/8 inch or more at any point 1/ 2/		224
	Minimum soft armor extending beyond edge of Insert is not achieved	122	

*The presence of a number designates either major or minor. The value of the number is for internal inspection purposes only.

1/ to be scored when condition exists for a length of more than 2 inches or if condition exists in several areas with an accumulated distance of 4 inches.

2/ the front filler or back filler individual components, as applicable shall be examined with the applicable cutting pattern centered on the filler components.

APPENDIX D: BALLISTIC PERFORMANCE VERIFICATION

Table I-A. Requirements and Verifications (see 4.5)

CHARACTERISTIC	REQUIREMENT PARAGRAPH	VERIFICATION PARAGRAPH	First Article Test	EVALUATED BY:
<i>Ballistic Protection Levels</i>	3.5.1	4.1, 4.4, & 4.6	X	
Ballistic Performance	3.5.2	4.6	X	
PLATE CARRIER <i>Fragmentation</i> Protection	3.5.2.2	4.6	X	
Handgun Protection	3.5.2.3	4.6	X	

Table I-B. Requirements and Verifications (see 4.5)

CHARACTERISTIC	REQUIREMENT PARAGRAPH	VERIFICATION PARAGRAPH	LOT ACCEPTANCE TESTING	EVALUATED BY:
<i>Ballistic Protection Levels</i>	3.5.1	4.1, 4.4, & 4.6	X	
Ballistic Performance	3.5.2	4.6	X	
PLATE CARRIER <i>Fragmentation</i> Protection	3.5.2.2	4.6	X	
Handgun Protection	3.5.2.3	4.6	X	

BALLISTIC FIRST ARTICLE TEST PROTOCOL: PLATE CARRIER Ballistic First Article Testing shall be conducted in accordance with the requirements of this purchase description and the following:

Instructions for Shoot-Pack Measurement

1. Remove the ballistic filler packet from the ballistic filler carrier
2. Weigh and record the ballistic filler packet separate from the ballistic filler carrier.
3. Place the ballistic filler packet on a flat unyielding surface having a straight backstop in which to press the ballistic filler packet against
4. Ensure that the ballistic filler packet is completely flat and firmly against the backstop but without creating any bulges in the packet
5. Measure the distance in *inches* from front to back in three locations; (1) one inch from right edge, (2) 7.5 inches from the right edge and (3) one inch from the left edge. Record each measurement using 1/16” resolution. NOTE: If applicable, do not include the ballistic filler packet *cover* in the measurement. Gently press against the seam to find the packet’s linear edge and use this for measurement.
6. Rotate the ballistic filler packet 90 degrees clockwise and repeat step #4.

Diagram I. Shoot-Pack Measurement Set-up

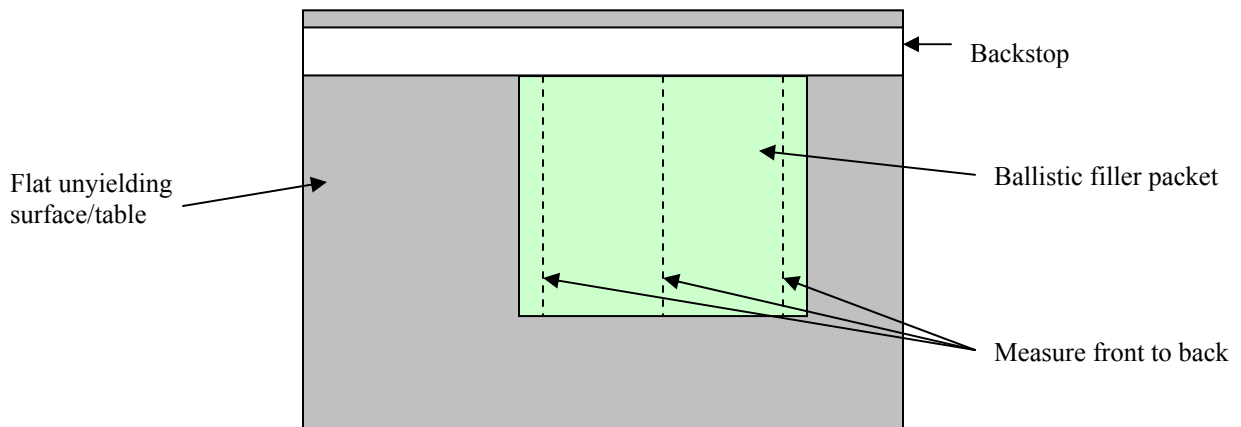

Table II. First Article Test Matrix

TEST	Frag, 2gr	Frag, 4gr	Frag, 16gr	Frag, 64gr	9mm Handgun	Need	Spec Paragraph
V50, dry, 0°	X	X	X	X		4 shoot-pack	3.5.2.2 4.6.1
V50, wet, 0°	X	X	X	X		4 shoot-pack	3.5.2.2 4.6.1.1.1
V50, dry, 45°	X	X	X	X		8 shoot-pack	3.5.2.2
V50, high T			X			1 shoot-pack	3.5.2.2 4.6.1.1.2
V50, low T			X			1 shoot-pack	3.5.2.2 4.6.1.1.2
V50, Accelerated aging			X			1 shoot-pack	3.5.2.2 4.6.1.1.3
V50, POL oil			X			1 shoot-pack	3.5.2.2 4.6.1.1.4
V50, POL gas			X			1 shoot-pack	3.5.2.2 4.6.1.1.4
V50					X	1 shoot-pack	3.5.2.3
V0					X	1 shoot-pack	3.5.2.3
Vs/Vr, 0°	X	X	X	X		4 shoot-pack	4.6.4
Vs/Vr, 45°	X	X	X	X		8 shoot-pack	4.6.4
Contingency						8 shoot-pack	3.5.2.2
Total						43 shoot-pack	3.5.2.2

SPECIAL PROVISIONS: All production quantities submitted after approval of the First Article Test shall be produced using the same raw material suppliers of the same materials, processes, procedures, equipment and facilities that resulted in the manufacture of the acceptable First Article Test items. This includes all raw materials and/or sub-components. Any change in the production of the approved First Article Test items, to include raw material supplier production processes, must be reported in writing to the Contracting Officer and the Contracting Officer's Technical Representative (COTR) for determination if a new First Article Test is required.

First Article Test Instruction:

For all V50, Vs/Vr, shot patterns as specified below. Starting velocity shall be approximately 100 fps above required minimum V50. Follow up & down procedure as specified in MIL-STD-662F.

Diagram II. First Article Test Shot Patterns

0 degree obliquity
16 shots

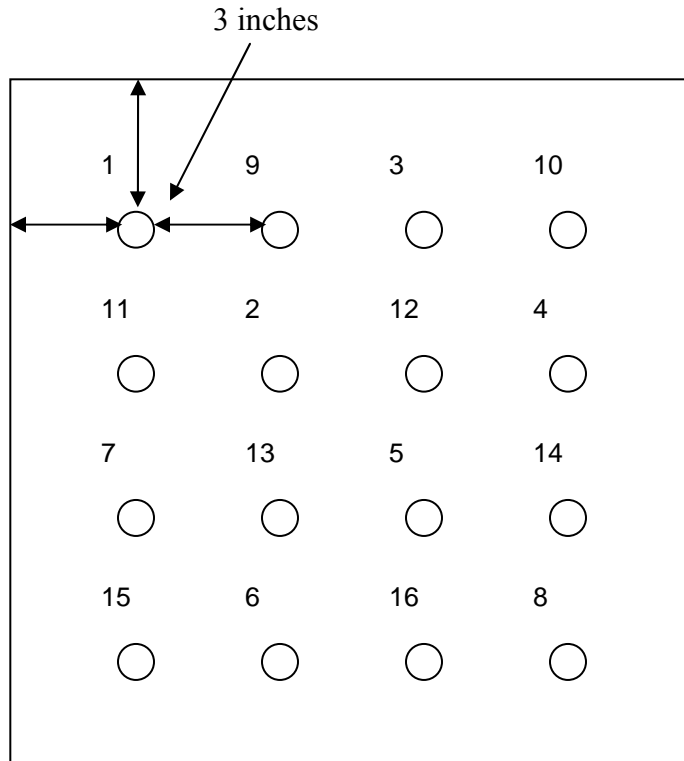

45 degree obliquity
12 shots

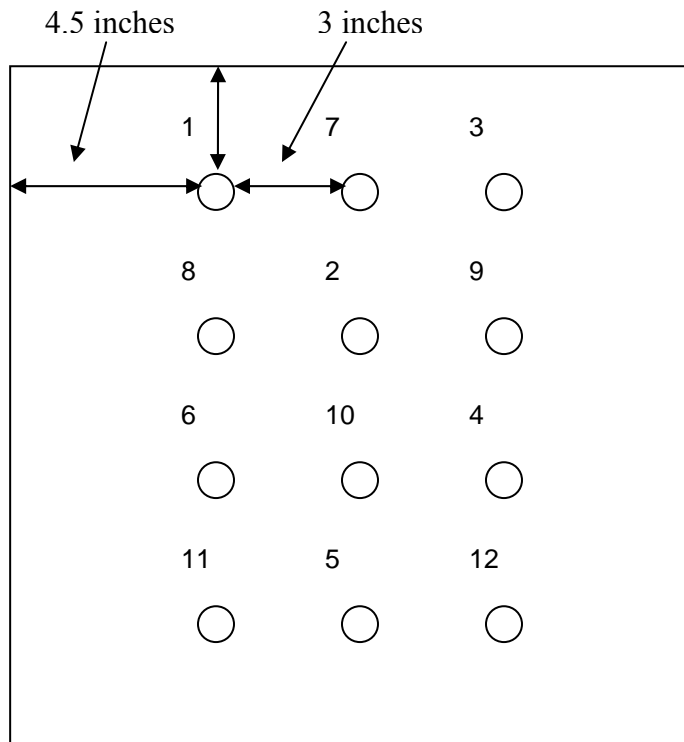

Table III. Vs/Vr starting velocity

Projectile	Starting Velocity
2- grain RCC	4900 ft/s
4- grain RCC	4900 ft/s
16-grain RCC	4600 ft/s
64-grain RCC	4000 ft/s

BALLISTIC LOT ACCEPTANCE TEST PROTOCOL: PLATE CARRIER Lot Acceptance Testing shall be conducted in accordance with the requirements of this purchase description and the following:

Table IV. Lot Acceptance Test Sample Selection Matrix, Base Vest

Lot Size	Number of test panels for threat			Requirements			Total Samples	One vest Reference Test	Total Vests
	V50, 17gr	V50, 9mm	V0, 9mm	V50, 17gr	V50, 9mm	V0, 9mm			
26 to 150	2	2	2	1850 fps min	1525 fps min	1400 + 50 fps	6	1	4
151 to 1200	4	4	4				12	1	7
1201 to 3200	6	6	6				18	1	10

V0 and V50 determination tested in accordance with paragraph 4.6
V50 reference testing data is for government reference only

Each PLATE CARRIER consists of one front panel and one back panel. The panels should be rotated for different threats. For example, first PLATE CARRIER sample, front panel should be tested for 17gr. V50, and the back panel should be tested for 9mm V0; the second PLATE CARRIER sample, front panel should be tested for 9mm V50, the back panel should be tested for 17 gr. V50, and so on. Lot Acceptance Testing conducted on front and back base vest panels shall constitute Lot Acceptance Testing for the side plate pockets, as long as those components ballistic fillers were cut within the same lot of front and back base vest panels that were subject to Lot Acceptance Testing.

SPECIAL PROVISIONS

- 1) First Article Test approval remains in effect and production may continue unless:
 - a. The contractor fails Lot Acceptance Testing (LAT) requirements on two (2) consecutive lots. Should this occur, the contractor will immediately cease production (Stop Work) and conduct a Failure Analysis and provide such reports as required to facilitate the completion of a Corrective Actions Report (CAR) as directed by the Defense Contract Management Agency (DCMA) Quality Assurance Representative (QAR). The CAR will then be submitted to the QAR and the Contracting Officer Representative (COR) for review NLT 15 days after occurrence. The QAR and COR will determine within five (5) working days after receipt of the CAR if production of the approved First Article Test configuration may resume or if the contractor must conduct a new First Article Test for the issuance of a new First Article Test Approval Letter. If a new First

Article Test is required, the contractor will submit the number of samples required to conduct a new First Article Test (at the contractor's expense) as directed by the COR, for the issuance of a new First Article Test Approval Letter. The First Article Test Report remains the property of the Government.

b. The number of failed lots exceeds the maximum lot failures allowed under Table V below submitted during the period of the contract using the approved First Article Test design. Should this occur, the contractor must immediately cease all production (Stop Work), conduct a Failure Analysis and provide such reports as required to facilitate the completion of a CAR as directed by DCMA QAR. The CAR will then be submitted to the QAR and the COR for review NLT 15 days after occurrence. The QAR and COR will determine within five (5) working days after receipt of the CAR if they are satisfied that the contractor has corrected the production issues that resulted in the lot failures. The contractor will then submit the number of samples required to conduct a new First Article Test (at the contractor's expense) as directed by the COR, for the issuance of a new First Article Test Approval Letter. The First Article Test Report remains the property of the Government.

Table V. Maximum Lot Failures

Total Lots Submitted	Max Lot Failures Allowed
1-100	3
101-200	3
201-300	3
Every 100 lots thereafter	3

c. The contractor does not manufacture a specific approved First Article Test design (when there are multiple approved designs) for a period of 180 consecutive production days. Non-production under this stipulation will result in automatic revocation of the First Article Test approval for that design.

Additionally, when a lot fails Lot Acceptance Testing and is subsequently rejected, that lot is rejected in its entirety and no ballistic component of that lot may be used in the production of any other lot. Further, any lot that is withdrawn prior to the completion of the Lot Acceptance Testing procedures as required by the Lot Acceptance Test Protocol will be considered as rejected and subject to the above conditions and restrictions. Additional Testing must be completed within 30 days of the initial Lot Acceptance Test. All failed Lot Acceptance Test's will require a Failure Analysis per the procedures outlined in 1) a.





2) BALLISTIC TESTING: ALL BALLISTIC TESTING FOR PRODUCTION LOTS SHALL BE CONDUCTED AT A GOVERNMENT TEST FACILITY OR AN NIJ CERTIFIED BALLISTIC LAB, AS DIRECTED BY THE CONTRACTING OFFICE. COPIES OF ALL BALLISTIC REPORTS ARE TO BE SUBMITTED TO THE COR FOR ACCEPTANCE PURPOSES.

3) BALLISTIC TESTING ON END ITEMS SHALL BE CONSIDERED LOT ACCEPTANCE TESTING. NOTIFY THIS OFFICE TEN DAYS PRIOR TO ANY TESTING IN THE EVENT THE GOVERNMENT WANTS TO WITNESS TESTING. NO LOT SHALL BE RELEASED FROM THE CONTRACTOR'S PLANT PRIOR TO RECEIPT OF PASSING TEST REPORTS THAT ARE APPROVED BY THE COR.

APPENDIX E: CONTENTS OF LABELS, AND USE AND CARE INSTRUCTIONS

Size, Identification, and Instruction Label. Label information is as listed within this appendix. Should an item be too small to mark with the complete label, label “C” will be utilized containing the Nomenclature, National Stock Number and any size information shall be used. Buckles, metal loops and other similar items not practically labeled shall have the appropriate label applied to the bulk packaging in accordance with MIL-STD-130. In addition to the man readable information listed in each example, a machine readable label with similar information will be included as either example “A” “B” or “C”: in the following schema:

Example “A”

MFR (CAGE) 54321	Lot# 12AB3
	
SER NO 12348	DOP 05/01/2009
	
NSN 8470-01-520-7373	PART # 55B123456789-10
	
CONTRACT F33657-80-C-0310 Size: Medium	
	



Example “B”

MFR (CAGE) 54321	Size: Medium
	
DOP 05/01/2009	NSN 8470-01-520-7373
	
PART # 55B123456789-10	CONTRACT F33657-80-C-0310
	



Example "C"

Size: Medium	Nomenclature: CUMMERBUND ADAPTER
NSN 8470-01-520-7373	PART # 55B123456789-10
CONTRACT F33657-80-C-0310	Cage: 01234

**PLATE CARRIER
FRONT CARRIER
U.S.**

THE PLATE CARRIER WITH ALL SOFT BALLISTIC PANELS INSTALLED PROVIDES PROTECTION FROM FRAGMENTATION AND 9MM SUBMACHINE GUN OR LESSER THREATS. THIS VEST DOES NOT PROTECT AGAINST KNIVES OR SHARP OBJECTS.

DO NOT MACHINE WASH OR DRY. FAILURE TO FOLLOW THESE INSTRUCTIONS WILL DAMAGE THE VEST'S PROTECTIVE CAPABILITY.

CLEANING INSTRUCTIONS

1. Remove dirt from outer surface with a cloth or soft bristle brush.
2. Remove the Enhanced Small Arms Protective Inserts (ESAPI) from the outer shell and the component carriers. Avoid submerging the PLATE CARRIER in water; DO NOT bleach! DO NOT machine wash! DO NOT dry clean! DO NOT apply solvents to the PLATE CARRIER! If the PLATE CARRIER becomes wet allow it to air dry flat away from heat sources and out of direct sunlight. If the ballistic panels become saturated with liquids such as bleaches, gasoline, petroleum, oils or lubricants, turn them in for replacement as soon as possible.
3. Hand wash the PLATE CARRIER base vest and component outer shells only in cold water with soap or a very mild detergent. DO NOT USE CAUSTIC CLEANERS, CHLORINE BLEACH, YELLOW SOAP, CLEANING FLUIDS OR SOLVENTS, WHICH WILL DISCOLOR AND DETERIORATE THE ITEMS!
4. Rinse the outer shells very thoroughly in clean water to wash out the soap.
5. Air-dry indoors, or in the shade, AWAY FROM HEAT SOURCES.
6. DO NOT ATTEMPT TO DYE THE ITEM OR FIX DISCOLORATIONS.

TURN IN YOUR ITEM IF:

1. Frags or bullets have hit them.
2. The outer cover is torn or damaged beyond field repair.
3. The hook and loop cannot be closed completely or repaired.
4. The webbing is torn or damaged beyond repair.
5. The items cannot be adequately cleaned, or are badly discolored.
6. The items have open seams or broken components.

MFR (CAGE) 54321

Lot# 12AB3



SER NO 12348

DOP 05/01/2009



NSN 8470-01-520-7373

PART # 55B123456789-10



CONTRACT F33657-80-C-0310 Size: Medium



**PLATE CARRIER
BACK CARRIER**

THE PLATE CARRIER WITH ALL SOFT BALLISTIC PANELS INSTALLED PROVIDES PROTECTION FROM FRAGMENTATION AND 9MM SUBMACHINE GUN OR LESSER THREATS. THIS VEST DOES NOT PROTECT AGAINST KNIVES OR SHARP OBJECTS.

DO NOT MACHINE WASH OR DRY. FAILURE TO FOLLOW THESE INSTRUCTIONS WILL DAMAGE THE VEST'S PROTECTIVE CAPABILITY.

CLEANING INSTRUCTIONS

1. Remove dirt from outer surface with a cloth or soft bristle brush.
2. Remove the Enhanced Small Arms Protective Inserts (ESAPI) from the outer shell and the component carriers. Avoid submerging the PLATE CARRIER in water; DO NOT bleach! DO NOT machine wash! DO NOT dry clean! DO NOT apply solvents to the PLATE CARRIER! If the PLATE CARRIER becomes wet allow it to air dry flat away from heat sources and out of direct sunlight. If the ballistic panels become saturated with liquids such as bleaches, gasoline, petroleum, oils or lubricants, turn them in for replacement as soon as possible.
3. Hand wash the PLATE CARRIER base vest and component outer shells only in cold water with soap or a very mild detergent. DO NOT USE CAUSTIC CLEANERS, CHLORINE BLEACH, YELLOW SOAP, CLEANING FLUIDS OR SOLVENTS, WHICH WILL DISCOLOR AND DETERIORATE THE ITEMS!
4. Rinse the outer shells very thoroughly in clean water to wash out the soap.
5. Air-dry indoors, or in the shade, AWAY FROM HEAT SOURCES.
6. DO NOT ATTEMPT TO DYE THE ITEM OR FIX DISCOLORATIONS.

TURN IN YOUR ITEM IF:

Frag or bullets have hit them.

1. The outer cover is torn or damaged beyond field repair.
2. The hook and loop cannot be closed completely or repaired.
3. The webbing is torn or damaged beyond repair.
4. The items cannot be adequately cleaned, or are badly discolored.
5. The items have open seams or broken components.

MFR (CAGE) 54321



SER NO 12348



NSN 8470-01-520-7373



CONTRACT F33657-80-C-0310 Size: Medium



Lot# 12AB3



DOP 05/01/2009



PART # 55B123456789-10



**PLATE CARRIER
U.S.**

THE PLATE CARRIER WITH ALL SOFT BALLISTIC PANELS INSTALLED PROVIDES PROTECTION FROM FRAGMENTATION AND 9MM SUBMACHINE GUN OR LESSER THREATS. THIS VEST DOES NOT PROTECT AGAINST KNIVES OR SHARP OBJECTS.

DO NOT MACHINE WASH OR DRY. FAILURE TO FOLLOW THESE INSTRUCTIONS WILL DAMAGE THE VEST'S PROTECTIVE CAPABILITY.

CLEANING INSTRUCTIONS

1. Remove dirt from outer surface with a cloth or soft bristle brush.
2. Remove the Enhanced Small Arms Protective Inserts (ESAPI) from the outer shell and the component carriers. Avoid submerging the PLATE CARRIER in water; DO NOT bleach! DO NOT machine wash! DO NOT dry clean! DO NOT apply solvents to the PLATE CARRIER! If the PLATE CARRIER becomes wet allow it to air dry flat away from heat sources and out of direct sunlight. If the ballistic panels become saturated with liquids such as bleaches, gasoline, petroleum, oils or lubricants, turn them in for replacement as soon as possible.
3. Hand wash the PLATE CARRIER base vest and component outer shells only in cold water with soap or a very mild detergent. DO NOT USE CAUSTIC CLEANERS, CHLORINE BLEACH, YELLOW SOAP, CLEANING FLUIDS OR SOLVENTS, WHICH WILL DISCOLOR AND DETERIORATE THE ITEMS!
4. Rinse the outer shells very thoroughly in clean water to wash out the soap.
5. Air-dry indoors, or in the shade, AWAY FROM HEAT SOURCES.
6. DO NOT ATTEMPT TO DYE THE ITEM OR FIX DISCOLORATIONS.

TURN IN YOUR ITEM IF:

Fragments or bullets have hit them.

6. The outer cover is torn or damaged beyond field repair.
7. The hook and loop cannot be closed completely or repaired.
8. The webbing is torn or damaged beyond repair.
9. The items cannot be adequately cleaned, or are badly discolored.
10. The items have open seams or broken components.

MFR (CAGE) 54321

Size: Medium



DOP 05/01/2009

NSN 8470-01-520-7373



PART # 55B123456789-10

CONTRACT F33657-80-C-0310



CUMMERBUND
U.S.
:

Refer to PLATE CARRIER or IMTV outershell label for cleaning and maintenance instructions.

MFR (CAGE) 54321

Size: Medium



DOP 05/01/2009

NSN 8470-01-520-7373



PART # 55B123456789-10



CONTRACT F33657-80-C-0310



**SIDE PLATE POCKET
U.S.**

Refer to PLATE CARRIER or IMTV outershell Label for cleaning and maintenance instructions.

MFR (CAGE) 54321



SER NO 12348



NSN 8470-01-520-7373



CONTRACT F33657-80-C-0310 Size: N/A



Lot# 12AB3



DOP 05/01/2009



PART # 55B123456789-10



QUICK RELEASE PULL CABLE

Refer to PLATE CARRIER or IMTV outershell Label for cleaning and maintenance instructions.

:

Size: Medium

Nomenclature: CABLE ASSEMBLY

NSN 8470-01-520-7373

PART # 55B123456789-10

CONTRACT F33657-80-C-0310

Cage: 01234

CUMMERBUND ADAPTER

Refer to PLATE CARRIER or IMTV outershell label for cleaning and maintenance instructions.

Size: Medium Nomenclature: CUMMERBUND ADAPTER
NSN 8470-01-520-7373 PART # 55B123456789-10
CONTRACT F33657-80-C-0310 Cage: 01234

SHOULDER STRAP

Refer to PLATE CARRIER or IMTV outershell Label for cleaning and maintenance instructions.

Size: N/A Nomenclature: Shoulder Strap
NSN 8470-01-520-7373 PART # 55B123456789-10
CONTRACT F33657-80-C-0310 Cage: 01234

YIB-YAB – SHOULDER STRAP

Refer to PLATE CARRIER or IMTV outershell Label for cleaning and maintenance instructions.

Size: N/A Nomenclature: YIB-YAB – SHOULDER STRAP
NSN 8470-01-520-7373 PART # 55B123456789-10
CONTRACT F33657-80-C-0310 Cage: 01234

APPENDIX F: PLATE CARRIER AND COMPONENT DRAWINGS
(For general reference only, not to be used in place of patterns)

PLATE CARRIER LEFT SIDE FRONT WITH CUMMERBUND

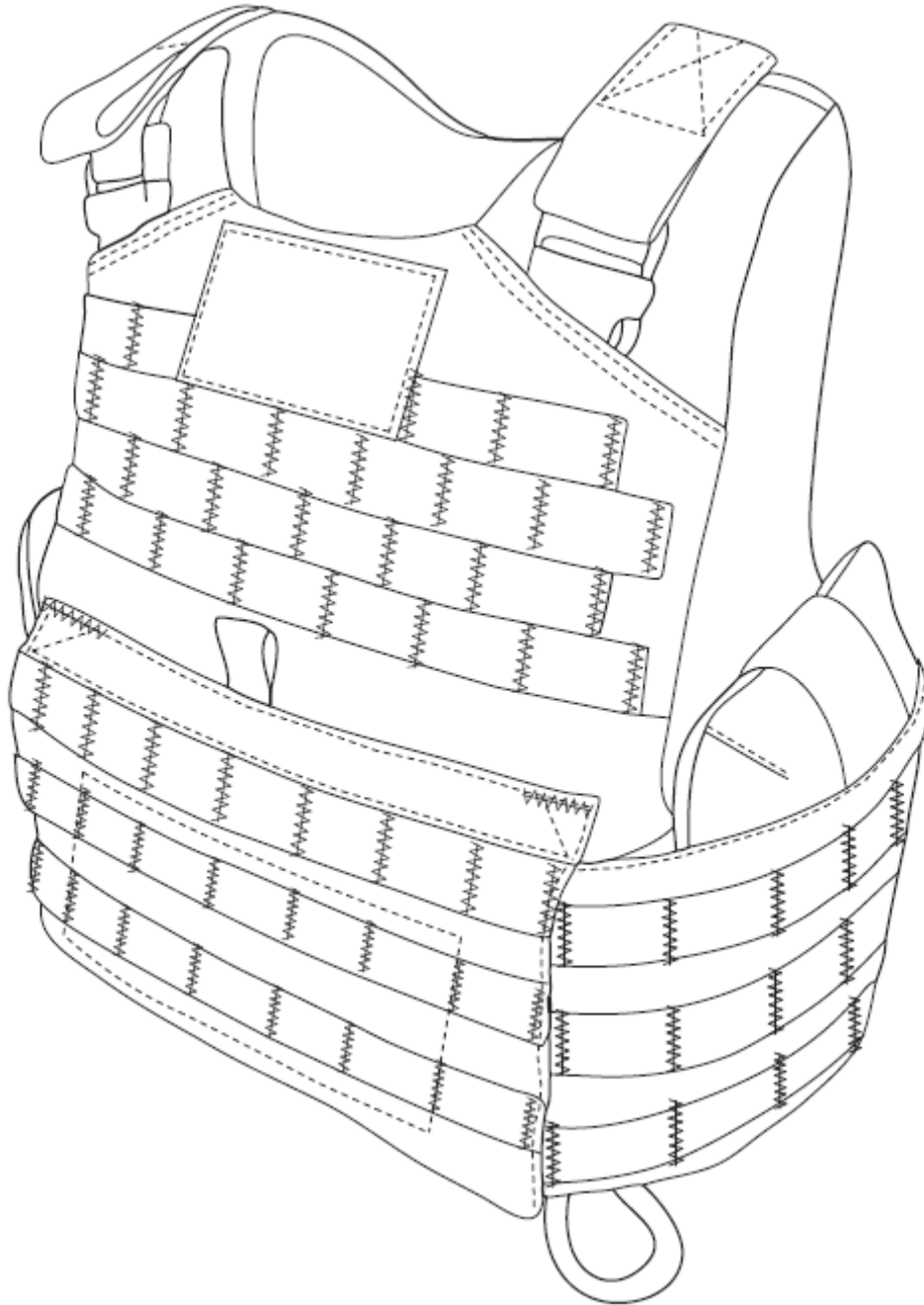

PLATE CARRIER FRONT PANEL

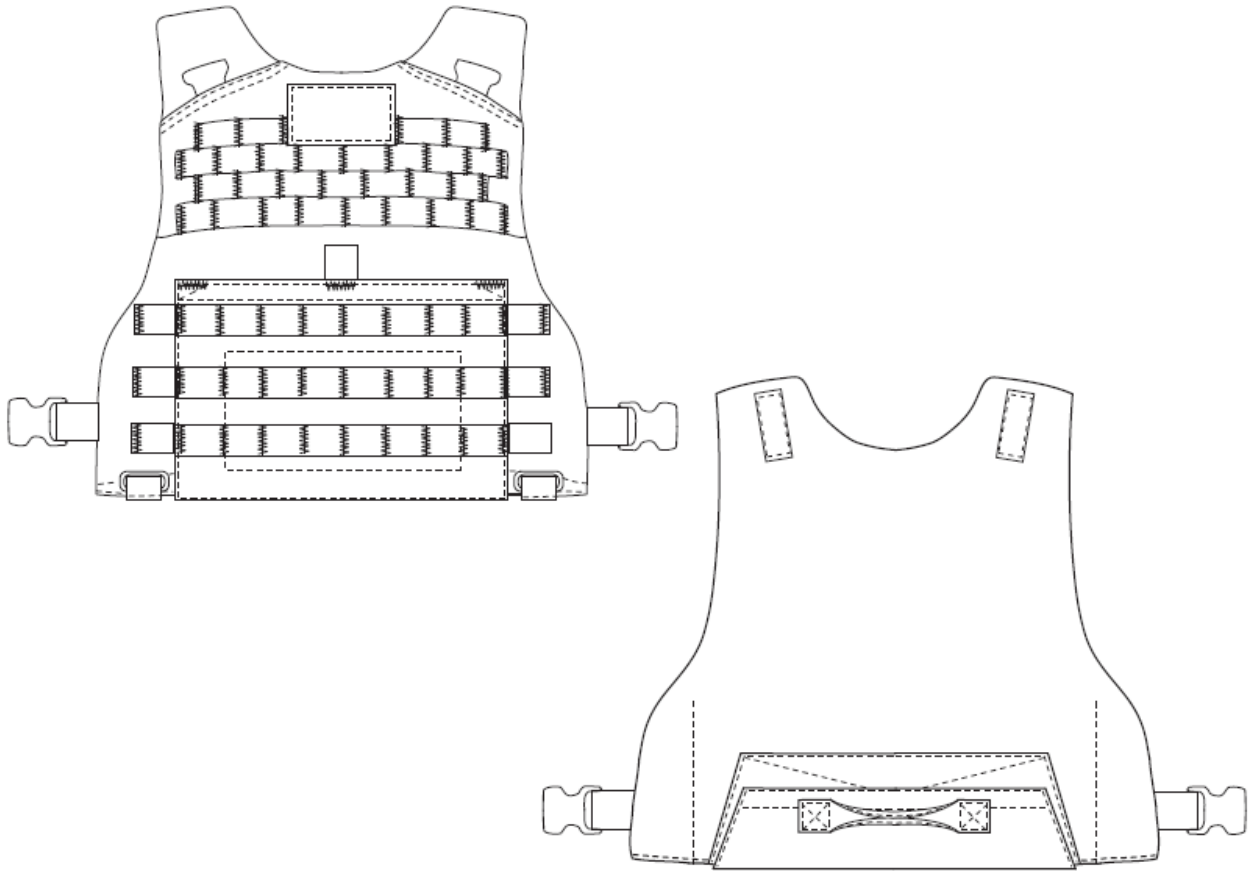

PLATE CARRIER BACK PANEL

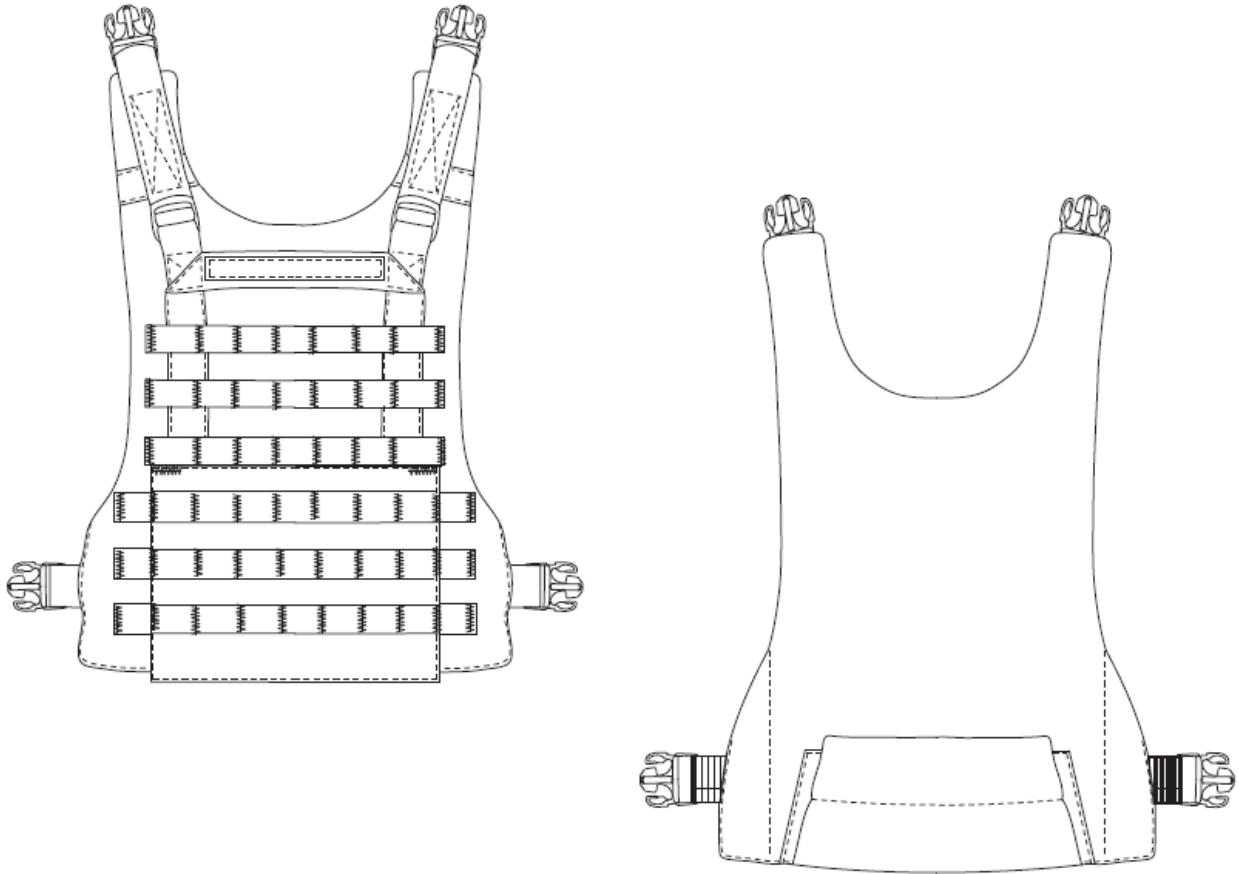
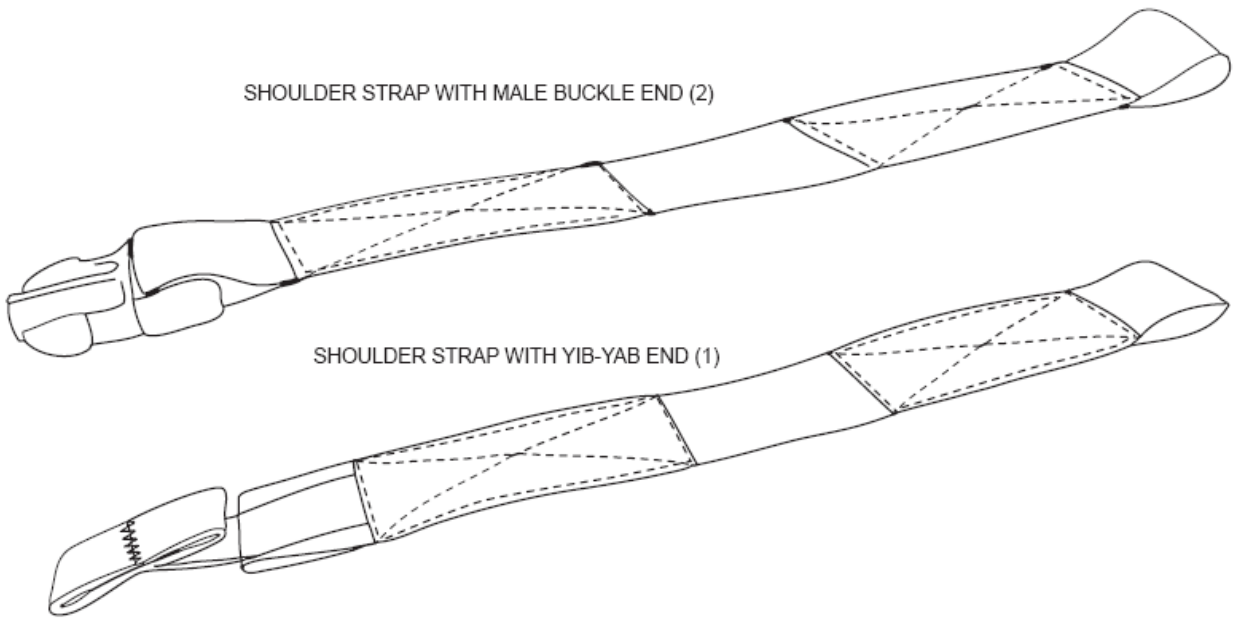
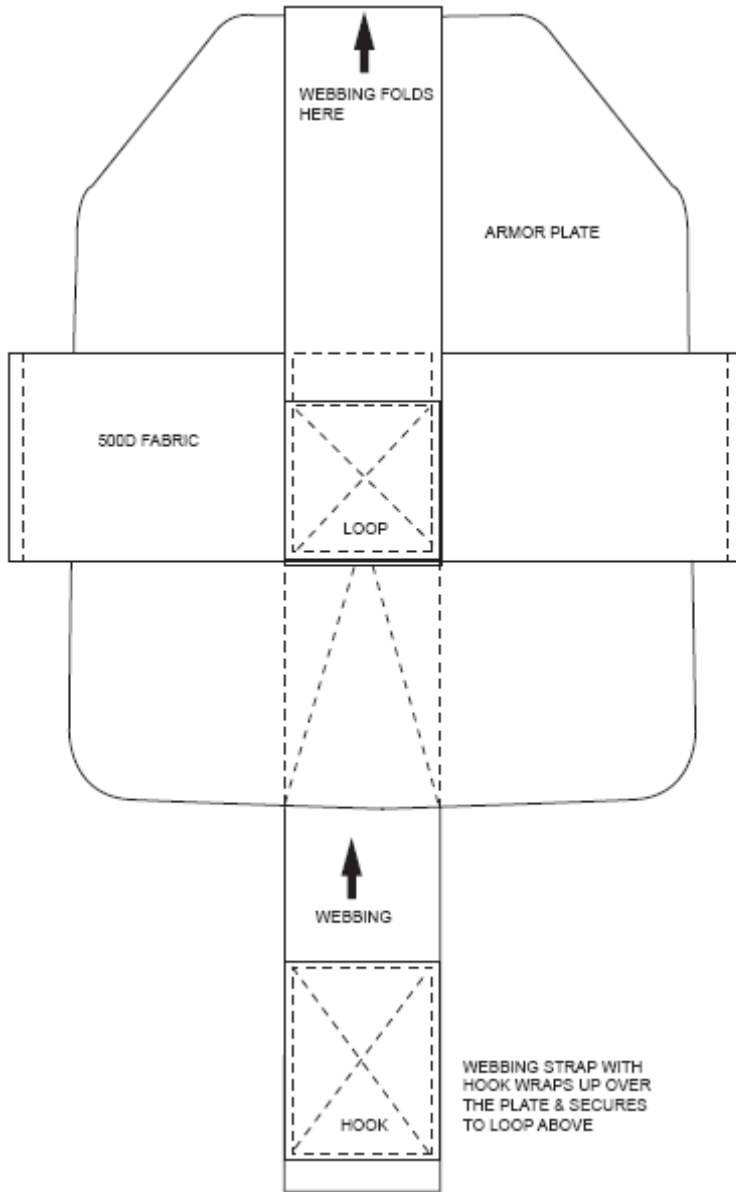

PLATE CARRIER SHOULDER STRAPS



* NOT TO SCALE

PLATE CARRIER FRONT AND BACK INNER PLATE POCKET



CUMMERBUND OUTER AND INNER SHELL VIEW

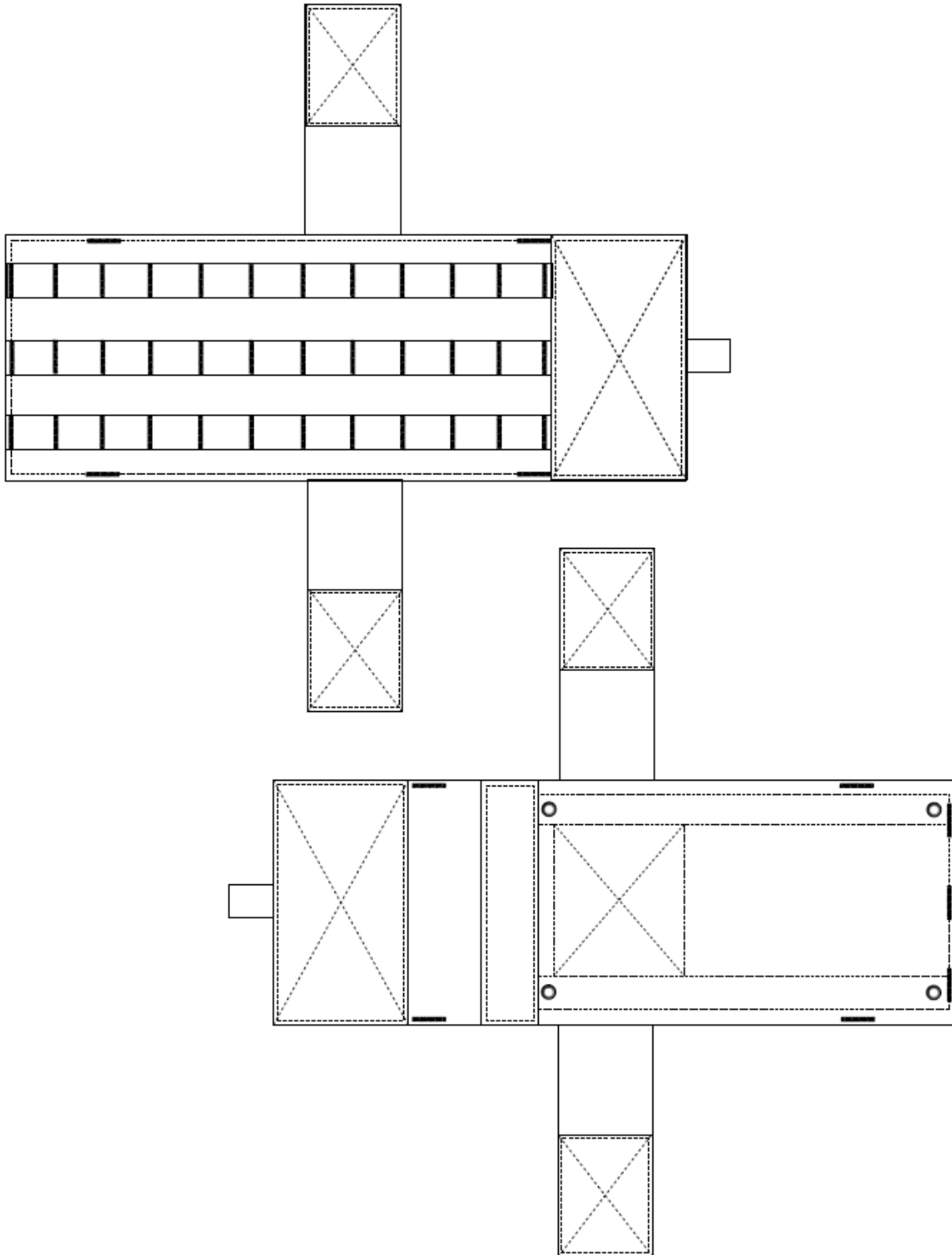

CUMMERBUND SIDE PLATE POCKET CHANNEL

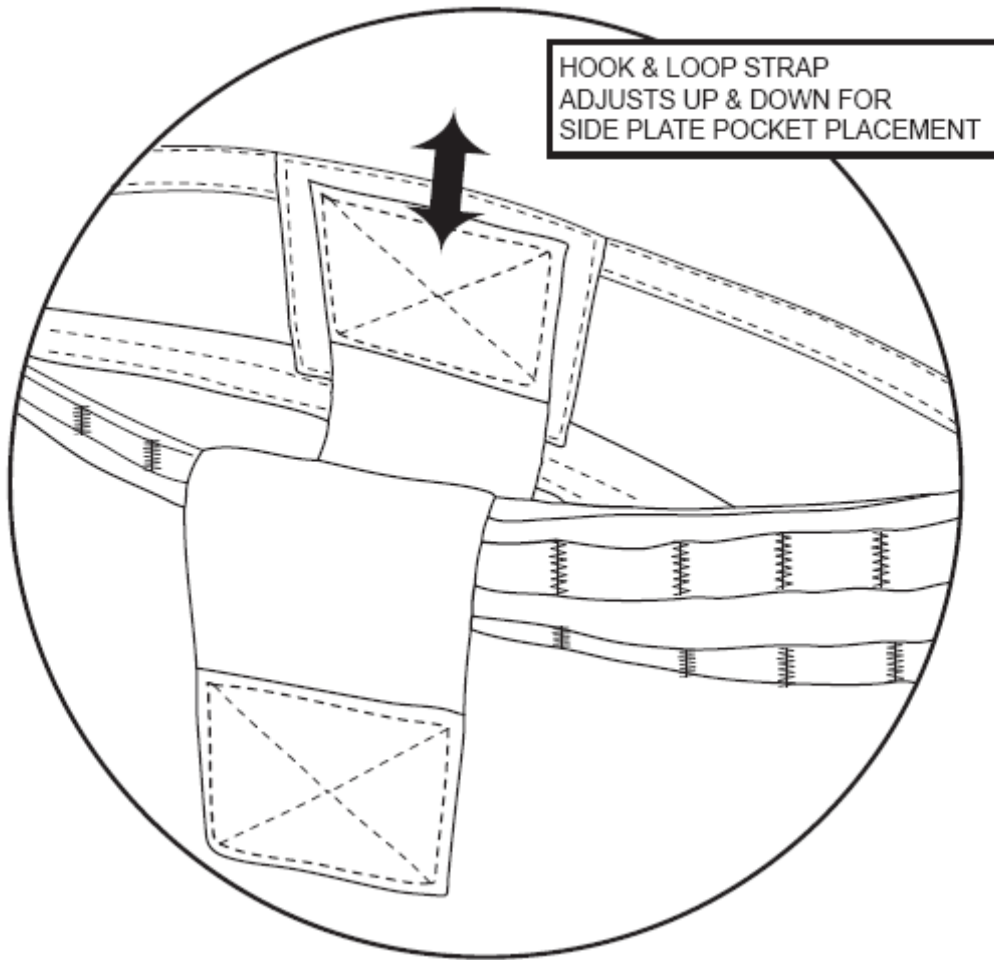

SIDE PLATE POCKET INNER AND OUTER SHELL VIEW

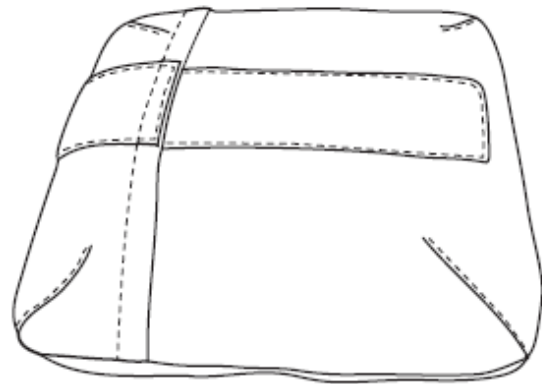
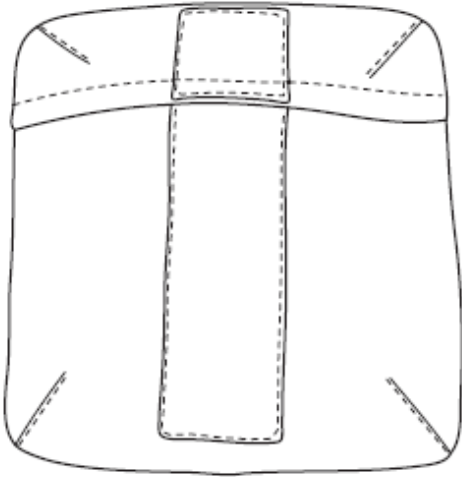
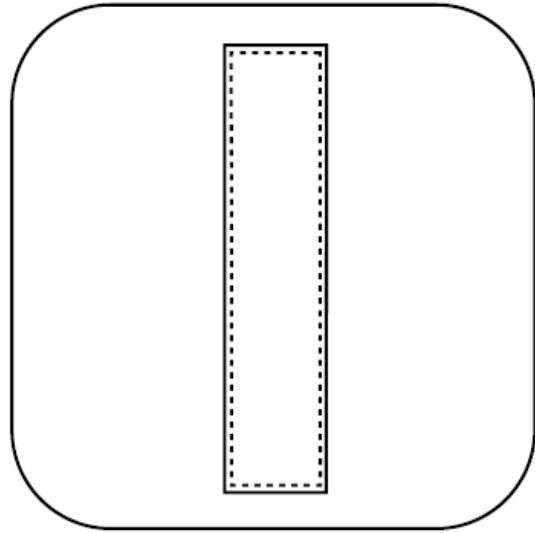
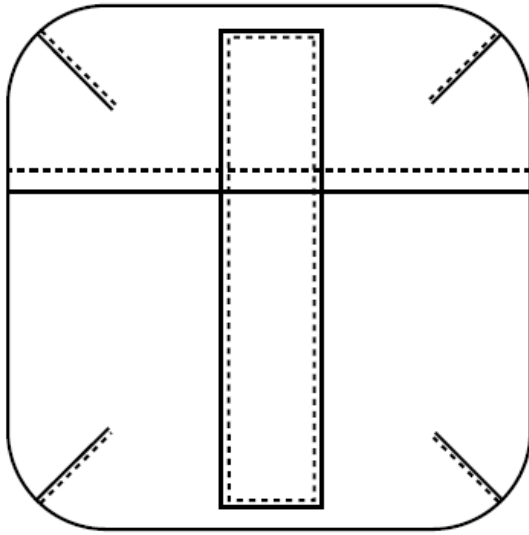

CUMMERBUND ADAPATERS

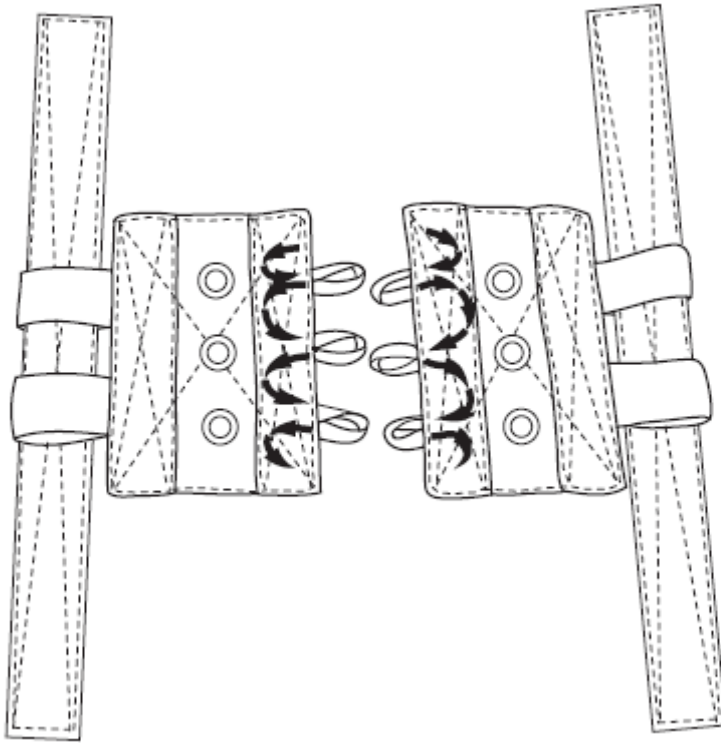

INSIDE ROUTING FOR
CORD SHOWN WITH
ARROWS

QUICK RELEASE PULL CABLE

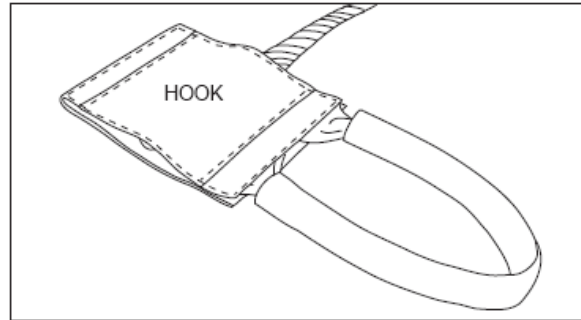
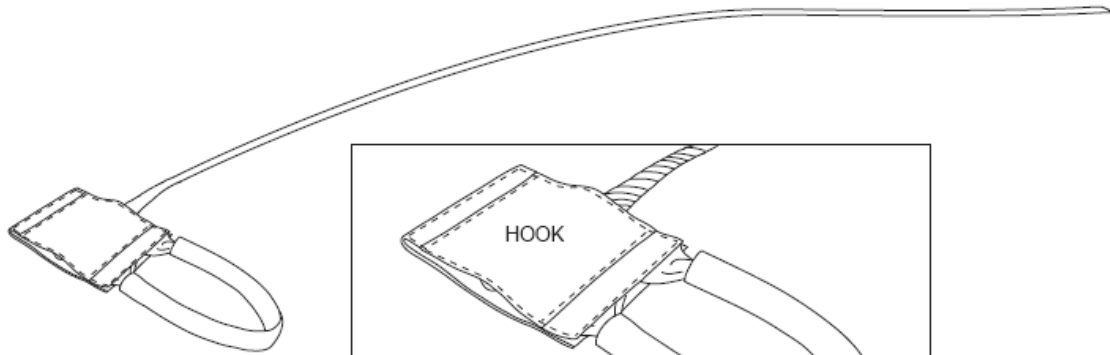

5/32" COPPER
SLEEVE

5 1/2" OF 2" WEBBING

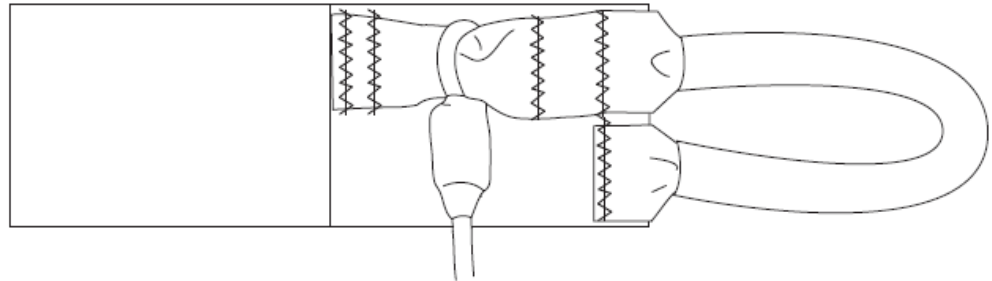

ATTACHMENT OF CUMMERBUND ADAPTERS AND QUICK RELEASE CABLE

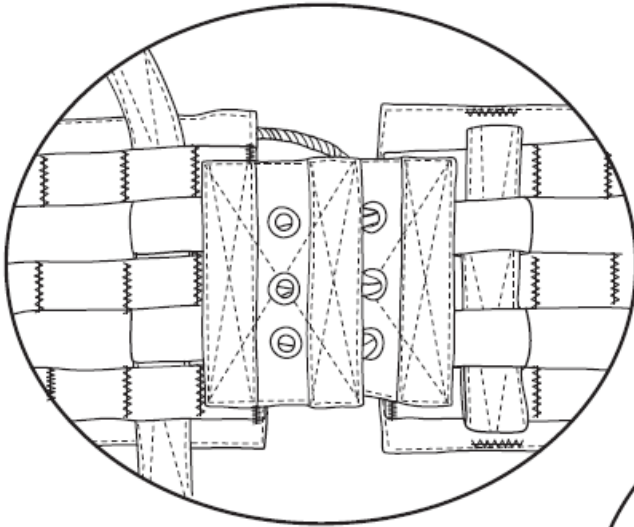

TOP SIDE OF CUMMERBUND WITH ADAPTOR & QUICK
RELEASE PULL CABLE FIXED

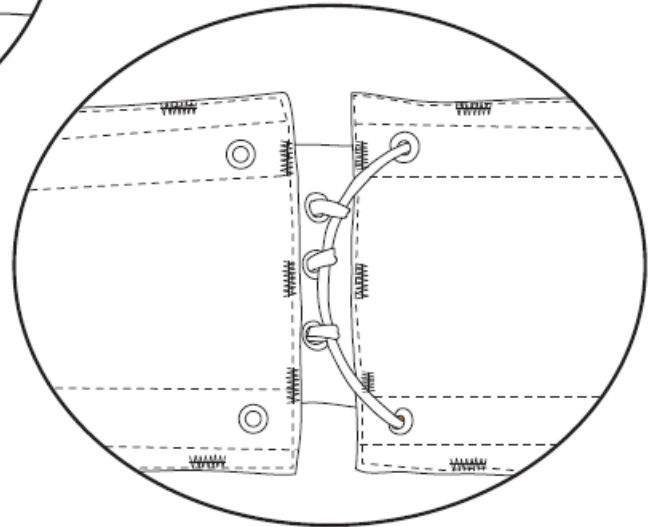

UNDER SIDE OF CUMMERBUND WITH ADAPTOR &
QUICK RELEASE PULL CABLE FIXED

PLATE CARRIER FRONT AND BACK CUMMERBUND FLAPS

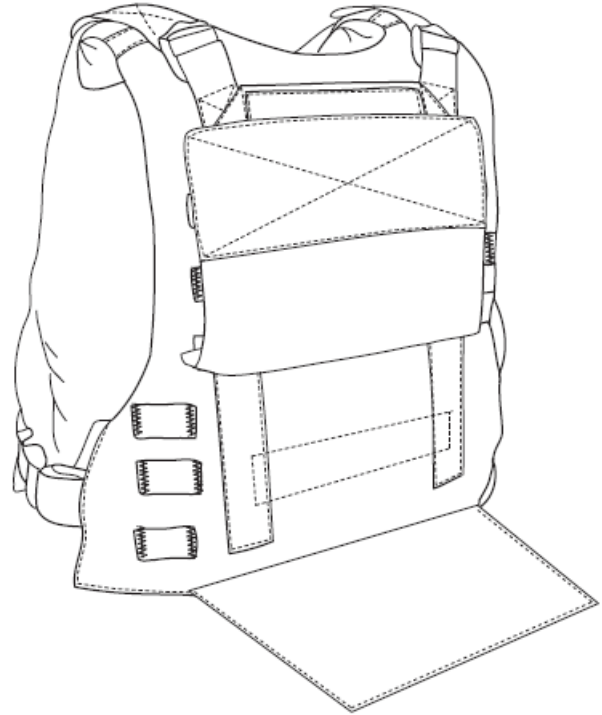
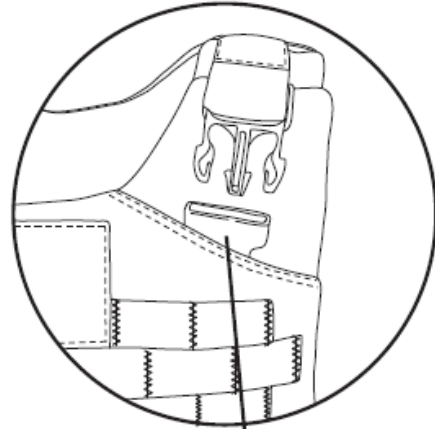
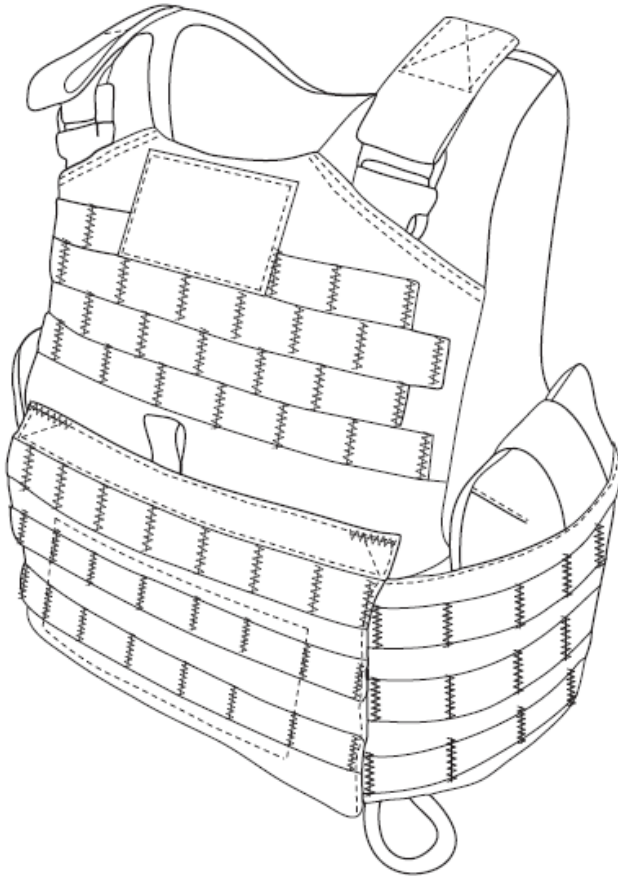

PLATE CARRIER FRONT AND BACK ATTACHMENT



PLATE CARRIER FRONT SHOULDER ATTACHMENT



INSIDE VIEW



FEMALE BUCKLE END & METAL LOOP FOR
YIB-YAB SHOULDER STRAP OPTION